



Sirman Spa
 Viale dell'Industria 9/11
 35010 PIEVE DI CURTAROLO (PD), Italy
 Tel./Fax. +39 049 9698666 / +39 049 9698688
 email: info@sirman.com



Sirman Slicers , model Mirra 300 Y09 :

- Anodized cast aluminium alloy.
- Great distance between blade and motor for easy cleaning.
- Ventilated motor.
- Forged, hardened large thickness blades.
- Carriage running on self-lubricating bushes and lapped pins.
- Stainless steel screws and slice deflector.
- Strong thickness gauge support.
- Cast-in sharpener assembly.
- Compact dimensions and great cutting capacity.
- CE professional with device for releasing the carriage.
- Teflon coated or toothed blades are available on demand.
- 25° blade inclination.



Enclosed and sealed belt pulley standard



More space between blade and body machine



Device for releasing the carriage

Data sheet

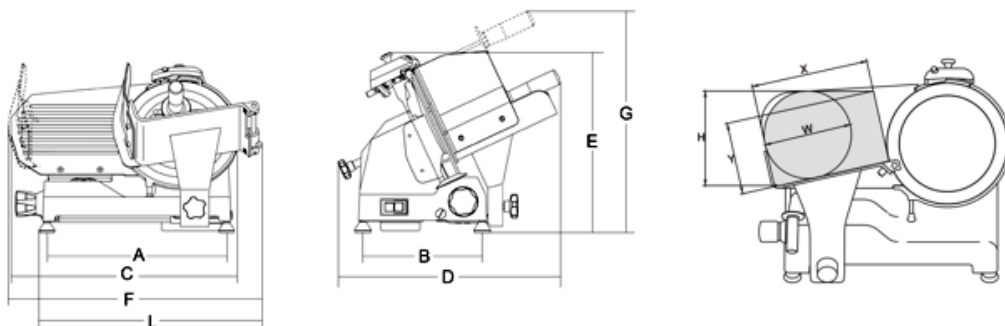

Technical data

Model	Mirra 300 Y09
Blade	mm 300 - inch. 12
Motor	watt 210 / Hp 0,29
Cut thickness	mm 13
Run of carriage	mm 285
Hopper	mm 250x275
A	mm 435
B	mm 295
C	mm 600
D	mm 610
E	mm 420
F	mm 640
G	mm 510
L	mm 535
X	mm 250
Y	mm 185
H	mm 225
W	mm 210
Net weight	kg 20,5
Shipping	mm 800x600x520

Gross weight	kg 23.5
HS-CODE	84385000