



Sirman Spa  
 Viale dell'Industria 9/11  
 35010 PIEVE DI CURTAROLO (PD), Italy  
 Tel./Fax. +39 049 9698666 / +39 049 9698688  
 email: info@sirman.com



Sirman Slicers , model Mirra 250 C :

- Anodized cast aluminium alloy.
- Great distance between blade and motor for easy cleaning.
- Ventilated motor.
- Forged, hardened large thickness blades.
- Carriage running on self-lubricating bushes and lapped pins.
- Stainless steel screws and slice deflector.
- Strong thickness gauge support.
- Cast-in sharpener assembly.
- Compact dimensions and great cutting capacity.
- CE professional with device for releasing the carriage.
- Teflon coated or toothed blades are available on demand.
- 25° blade inclination.



Enclosed and sealed belt pulley standard



More space between blade and body machine



Device for releasing the carriage



Optional: removable round slicer deflector

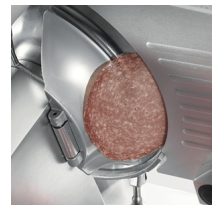

Data sheet

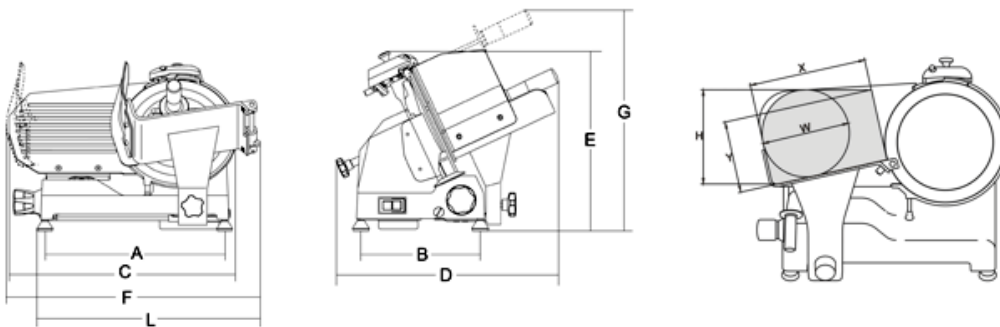

Technical data

Model	MIRRA 250 C
Ø Blade	mm/inch 250/10"
Motor	Watt 147 - Hp 0,20
Cut thickness	mm 13
Run of carriage	mm 245
Hopper	mm 230x240
A	mm 395
B	mm 245
C	mm 500
D	mm 560
E	mm 370
F	mm 570
G	mm 475
L	mm 490
X	mm 220
Y	mm 145
H	mm 180
W	mm 170
Net weight	Kg 16
Shipping	mm 600x500x420

Gross weight	Kg 18
HS-CODE	84385000