

CARACTÉRISTIQUES

- Standard avec cuve, fouet, palette et crochet.
- 3 vitesses.
- Machine robuste.
- Transmission mécanique.
- La machine doit être arrêtée pour le changement de vitesse.

FEATURES

- Standard with bowl, whip, flat beater and hook.
- 3 gears.
- Robust machine.
- Mechanical transmission.
- The machine has to be stopped to change gears.

EIGENSCHAPPEN

- Standaard met kuip, klopper, vlinder en haak.
- 3 snelheden.
- Robuste machine.
- Mechanische overbrenging.
- Machine moet gestopt worden om van snelheid te veranderen.



2 YEARS
WARRANTY

Standard avec cuve, fouet, palette et crochet.
Standard with bowl, whip, flat beater and hook.
Standaard met kuip, klopper, vliinder en haak.

3 vitesses.
3 gears.
3 snelheden.

Mouvement cuve.
Bowl operation.
Kuipverplaatsing.

SM-100C/200/200C



Levier.
Handle.
Hendel.

SM-500C



Manivelle.
Handle wheel.
Draaiwiel.

Machine robuste.
Robust machine.
Robuste machine.

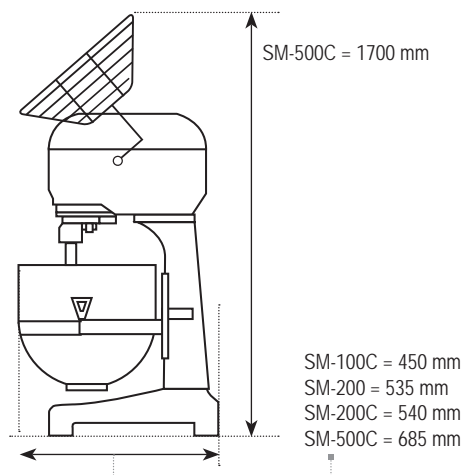
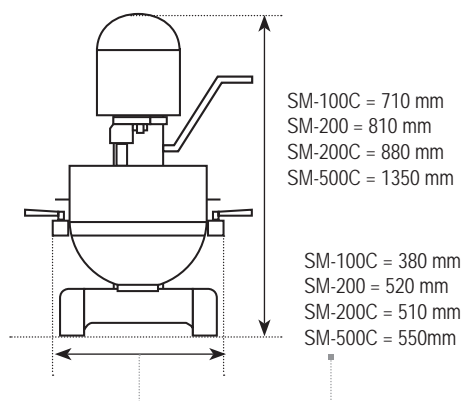
VUE LATÉRALE | SIDE VIEW | ZIJAAZICHT

VUE DE FACE | FRONT VIEW | VOORAANZICHT

SM-100C
SM-200
SM-200C
SM-500C

MODEL	SM-100C	SM-200	SM-200C	SM-500C
CAPACITÉ CAPACITY CAPACITEIT (L)	10	20 (10 opt.)	20 (10 opt.)	40 (20 opt.)
PUISSANCE MOTEUR MOTOR POWER MOTORVERMOGEN	0,25 kW	0,9 kW	0,9 kW	1,2 kW
Trs/Min à 50 Hz R.P.M. at 50 Hz Omw/min bij 50 Hz 1re/2e/3e vitesse 1st/2nd/3d gear 1ste/2e/3e snelheid	148/307/509	158/293/535	158/293/535	116/208/464
POIDS NET MACHINE NET WEIGHT MACHINE NETTOGEWICHT MACHINE	67 kg	110 kg	100 kg	250 kg
OPTION RÉDUCTION DE CUVE OPTION BOWL REDUCTION OPTIE REDUCTIEKUIP et équipement - and tools - en werktuigen	✗	✓ 10 L	✓ 10 L	✓ 20 L
VOLTAGE VOLTAGE SPANNING	220V 1Ph 50Hz	220V 1Ph 50Hz	220V 1Ph 50Hz	220/380V 3Ph 50Hz*