

CARACTÉRISTIQUES

- Standard avec cuve, fouet, palette et crochet.
- 3 vitesses.
- Machine robuste.
- Transmission mécanique.
- La machine doit être arrêtée pour le changement de vitesse.

FEATURES

- Standard with bowl, whisk, flat beater and hook.
- 3 gears.
- Robust machine.
- Mechanical transmission.
- The machine has to be stopped to change gears.

EIGENSCHAPPEN

- Standaard met kuip, klopper, vlinder en haak.
- 3 snelheden.
- Robuste machine.
- Mechanische overbrenging.
- Machine moet gestopt worden om van snelheid te veranderen.



Standard avec cuve, fouet, palette et crochet.
Standard with bowl, whisk, flat beater and hook.
Standaard met kuip, klopper, vlieder en haak.

3 vitesses.
3 gears.
3 snelheden.

Mouvement cuve.
Bowl operation.
Kuipverplaatsing.

SM-200/SM2-200C



Levier.
Handle.
Hendel.

SM2-500C



Manivelle.
Handle wheel.
Draaiwiel.

Machine robuste.
Robust machine.
Robuste machine.

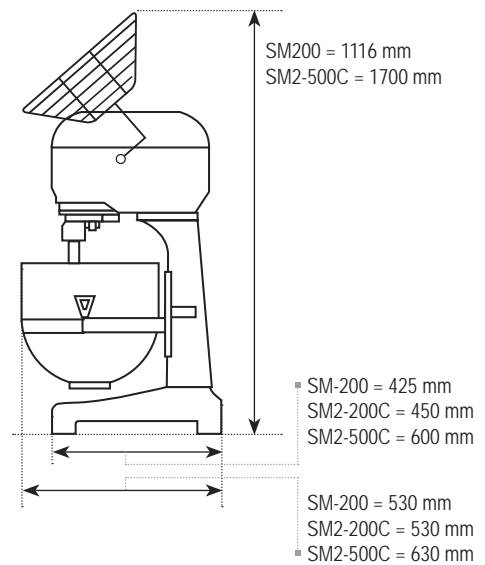
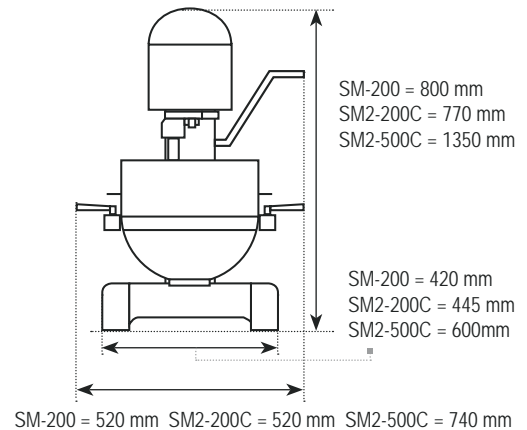
VUE LATÉRALE | SIDE VIEW | ZIJAAZICHT

VUE DE FACE | FRONT VIEW | VOORAANZICHT

SM-200



SM2-200C



SM2-500C

MODEL	SM-200	SM2-200C	SM2-500C
CAPACITÉ CAPACITY CAPACITEIT (L)	20 (10 opt.)	20	40 (20 opt.)
PUISSANCE MOTEUR MOTOR POWER MOTORVERMOGEN	0,9 kW	1,1 kW	1,1 kW
Trs/Min à 50 Hz R.P.M. at 50 Hz Omw/min bij 50 Hz 1re/2e/3e vitesse 1st/2nd/3d gear 1ste/2e/3e snelheid	158/293/535	158/293/535	116/208/464
POIDS NET MACHINE NET WEIGHT MACHINE NETTOGEWICHT MACHINE	110 kg	60 kg	190 kg
VOLTAGE VOLTAGE SPANNING	230V 1Ph 50Hz	230V 1Ph 50Hz	230/400V 50Hz
option réduction de cuve OPTION BOWL REDUCTION OPTIE REDUCTIEKUIP et équipement - and tools - en werktuigen	✓ 10 L	✗	✓ 20 L