

Carrello coibentato applicabile sia in zona vendita che nei reparti di lavorazione alimentare/stoccaggio

***Insulated cart for food retail area,
food process and cold storage applications***



**RBC200 – cm.83x74x74h
185 litri /liters**

**RBC300 - cm.84x74x99h
300 litri /liters**

**RBC500 - cm.128x98x91h
500 litri/liters**

in materiale plastico coibentato per aumentare l'isolamento termico; con ruote in nylon e maniglie per facilitare la movimentazione; provvisto di scarico acqua e rubinetto.

Made of double insulated plastic material, with nylon wheels and ergonomyc handles for easy maneuvrability; water drain with faucet.



Carrello coibentato applicabile sia in zona vendita che nei reparti di lavorazione alimentare/stoccaggio

***Insulated cart for food retail area,
food process and cold storage applications***

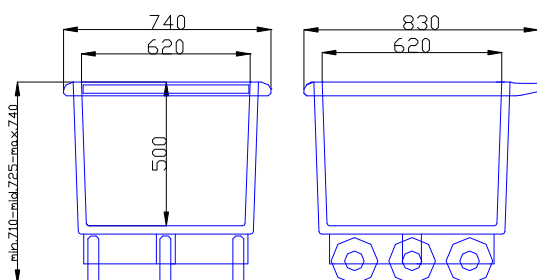

RBC200

Valvola di scarico prevista nei modelli RBC300 e RBC500

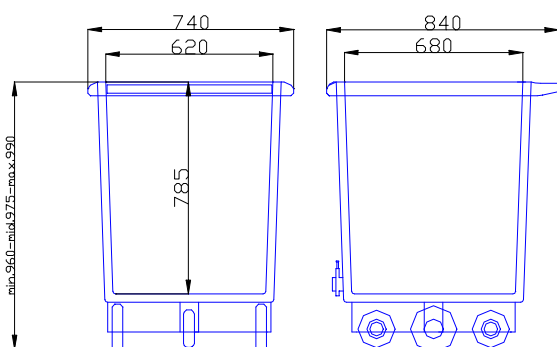

RBC300

*Faucet for water drain
standard on RBC300 and 500*

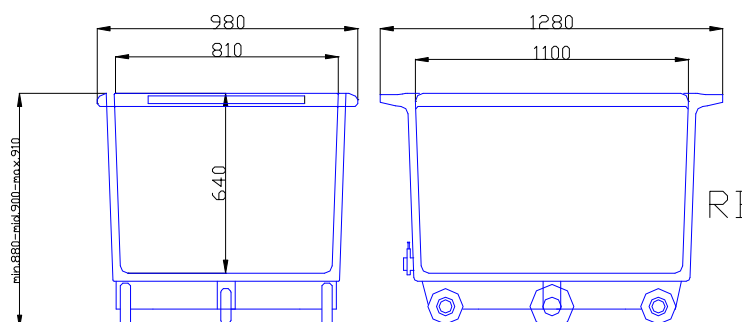

RBC500

Modello <i>model</i>	Dimensioni LxPxH <i>Overall size WxDxH (cm)</i>	Peso lordo <i>Gross Weight</i>
RBC200	74x83x74	22 Kg
RBC300	74x84x99	36 Kg
RBC500	98x128x91	42 Kg