

Specification

VarioCookingCenter® 311 (65 dm², 150 l)

Reference number:

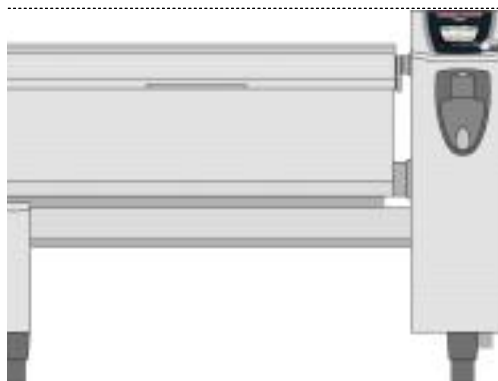

VarioCooking Control® - 7 process groups



Function: VarioCooking Control® mode

In the 7 cooking modes (meat, fish, vegetables and side dishes, egg dishes, soups and sauces, dairy products and desserts, Finishing® and service)

VarioCooking Control® automatically detects the product-specific requirements, the size of the food to be cooked and the load size. The cooking time and temperature are continuously adjusted to achieve the result you want. The operator is actively guided through the cooking processes. The remaining cooking time is displayed.

Manual mode

 Boiling: 30°C - BoilingT

 Frying: 30°C - 250°C

 Deep frying: 30°C - 180°C

VarioBoost®

 patented, net-type heating system for absolutely even and precise temperature transmission

Program – mode

 The program management function allows to create own programs, save and manage VarioCooking Control® processes and programs with individual settings.

Description

- Multifunctional cooking appliance for boiling, frying and deep frying, VarioCooking Control® - mode to automatically cook meat, fish, vegetables and side dishes, egg dishes, soups and sauces, dairy products and desserts, Finishing® and service.
- Manual mode for most of the cooking methods used in commercial kitchens. Suitable for boiling, frying and deep frying
- Temperature range: 30 - 250 °C

Working safety

- Cooking or washing water is emptied directly through the pan (without tilting and without floor drain)
- Operating and warning display, e.g. hot oil when deep frying
- Safety temperature limiter
- Maximum temperature of the pan sides 70 °C

Operation

- 8.5" TFT colour monitor and touch screen with self-explanatory symbols for ease of operation
- Central dial with "Push" function to confirm entries
- Application and user manuals can be called up on the unit display for the current action

Features

- Core temperature probe with 6 measuring points with patented core temperature probe holder
- VarioDose automatic highly accurate water filling device
- Fixed waste water connection possible as unit incorporates integral pipe isolating section
- VarioBoost® patented heating system
- Pan base TrimaTherm® - efficient and hard pan base made of three inseparable steel layers
- Cooking process control with microprocessor
- Integral hand shower with automatic retracting system and infinitely variable jet strength
- Integral socket
- USB port
- Ethernet
- Integral ON/OFF switch
- Variable foreign language display for messages from the unit
- Temperature unit can be toggled between °C and °F
- Digital temperature displays
- Actual and target value displays
- Digital timer, 0-24 hours with permanent settings, may be toggled between hour/min and min/sec
- 24-hour real-time clock
- Material: stainless steel DIN 1.4301, inside and outside
- Seamless hygienic pan with rounded corners
- Cooking pan tilted by electric cylinder
- Service Diagnostic System with service messages displayed automatically
- Protection class IP X5

Additional functions

- AutoLift raising and lowering device (baskets for boiled and deep-fried food)
- HACCP datamemory and outputting via USB port
- Individual programming of 350 cooking programs
- Delta-T cooking
- Energy efficiency tested according to DIN 18873 and consumption values published in database HKI CERT (Germany): <http://grosskuechen.cert.hki-online.de/en>

Installation

- Fixed waste water connection possible as unit incorporates integral pipe isolating section
- Can be set up without a floor drain
- Height-adjustable unit feet 150 to 175 mm
- All VarioCookingCenter® units are compatible with units and tables 850 mm high

Approval



Designer:

VarioCookingCenter® 311 (65 dm², 150 l)

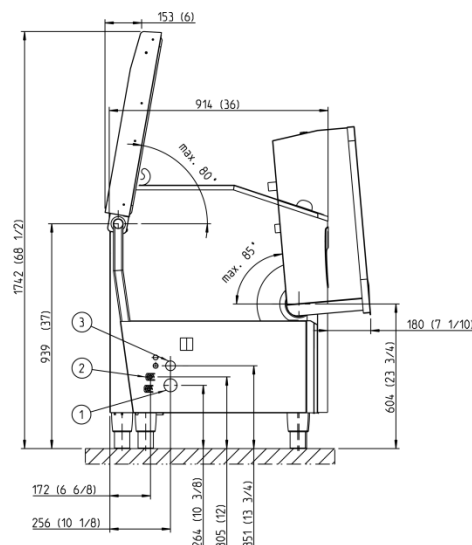
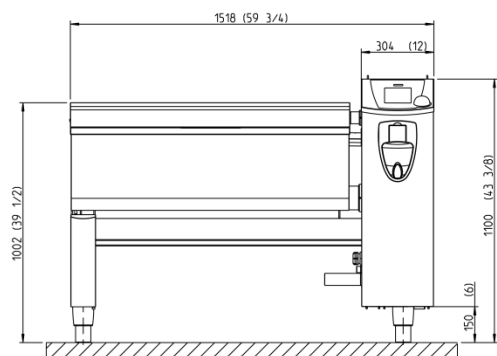

1. Drain connection DN50
2. Water supply cold G3/4
3. Electrical connection

Measurements in mm (inch)

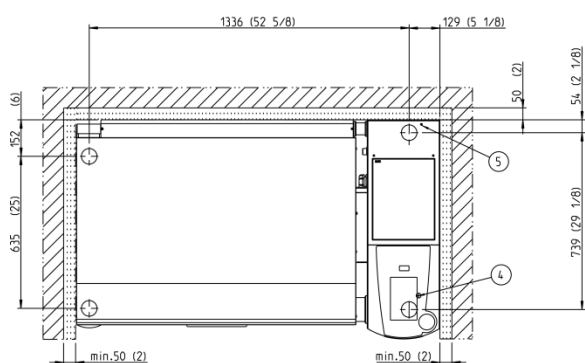

Technical Info

Working capacity	150 litre	Height of pan edge:	900 mm	Recommended air extraction rate*:	2,053 m ³ /h
Volume :		Water connection cold water:	R3/4" for 1/2" pressure hose	Connected load**:	45 kW - 3NAC
Pan Volume [WxDxH]:	1066 x 620 x 280 mm	Water pressure:	150-600 kPa / 1.5-6 bar		400-415V
Area [dm²]:	65 dm ²	Drain connection:	DN 50	Connected load with VitroCeran**:	47 KW - 3NAC
Capacity baskets:	3 x 1/1 GN	Thermal load latent:	11,385 W (253 W/ KW)	Fuse***:	400-415V
Width:	1518 mm	Thermal load sensitive:	1,417.5 W (31.5 W/ kW)	Incoming cable***:	80 A - 30 mA 4-pol
Depth:	914 mm			Maximum socket power:	5 x 16 mm ²
Height:	1100 mm				3,6 KW (16 A)
Weight:	251 kg				

Installation

- *In normal operation according to VDI 2052 (application mix 60% boiling, 38% frying, 2% deep-frying). In case of differing application prior to the construction of the room ventilation system, consult RATIONAL
- **Special voltages on request
- ***Values shown are for a maximum cable length of 2 m. It is the responsibility of the person installing the unit to adjust these values according to the length of cable which will be in use.
- Make sure that the device is connected separately to a 30mA RCD in the onsite distribution.
- Installations must comply with all local electrical, plumbing and ventilation codes (IEC364 or national standard in harmonisation with the IEC364)
- The right hand clearance must be a minimum of 14" (350mm) if heat sources are affecting the left right of the unit

Options

- VitroCeran with frame
- Connection to Sicotronic (others on request)
- Pressure cooking Mode
- Hot water connection
- Without deep-frying mode
- Special voltages on request
- with signal SOLAS
- stainless steel feet

Accessories

- Scraper
- Arm for automatic raising/lowering device
- Boiling and deep-frying basket
- Bain Marie Kit
- Colander
- Rack
- Oil cart
- VarioMobil®
- Kit for mouting on castors
- Kit for mouting on a plinth
- Body Kit
- Kit for wall suspension
- Water connection kit
- ConnectedCooking - the networking solution for professional kitchens