

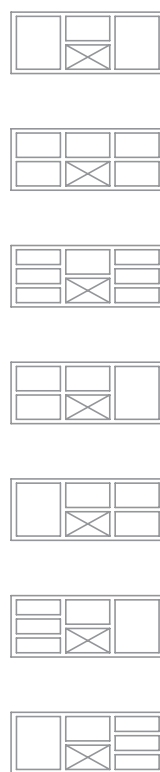

Model	Volume, l	°C	Input	Power
FP0-P202-130/70/90	361	+2 ... +8	1,8 A	410 W
FP0-V202-130/70/90	361	-5 ... +5	1,8 A	410 W
FP0-M202-130/70/90	361	-20 ... -18	2,3 A	529 W
FP0-P212-130/70/90	361	+2 ... +8	1,8 A	410 W
FP0-V212-130/70/90	361	-5 ... +5	1,8 A	410 W
FP0-M212-130/70/90	361	-20 ... -18	2,3 A	529 W
FP0-P222-130/70/90	361	+2 ... +8	1,8 A	410 W
FP0-V222-130/70/90	361	-5 ... +5	1,8 A	410 W
FP0-M222-130/70/90	361	-20 ... -18	2,3 A	529 W
FP0-P230-130/70/90	361	+2 ... +8	1,8 A	410 W
FP0-V230-130/70/90	361	-5 ... +5	1,8 A	410 W
FP0-M230-130/70/90	361	-20 ... -18	2,3 A	529 W
FP0-P231-130/70/90	361	+2 ... +8	1,8 A	410 W
FP0-V231-130/70/90	361	-5 ... +5	1,8 A	410 W
FP0-M231-130/70/90	361	-20 ... -18	2,3 A	529 W
FP0-P240-130/70/90	361	+2 ... +8	1,8 A	410 W
FP0-V240-130/70/90	361	-5 ... +5	1,8 A	410 W
FP0-M240-130/70/90	361	-20 ... -18	2,3 A	529 W
FP0-P241-130/70/90	361	+2 ... +8	1,8 A	410 W
FP0-V241-130/70/90	361	-5 ... +5	1,8 A	410 W
FP0-M241-130/70/90	361	-20 ... -18	2,3 A	529 W

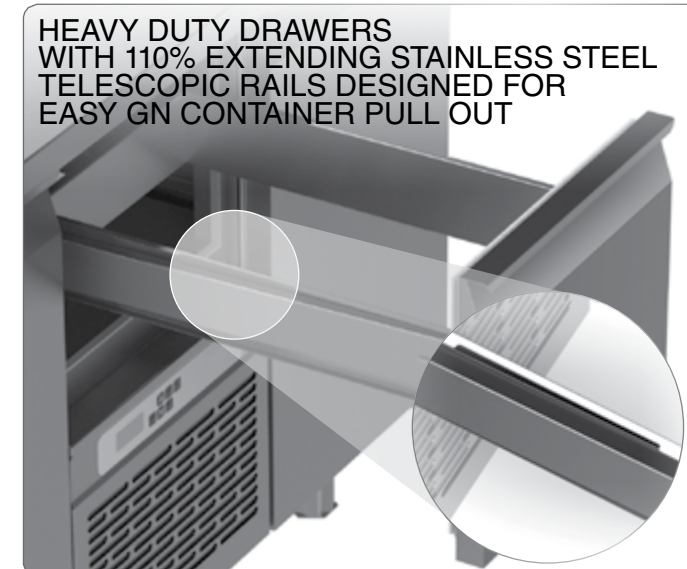

STANDARD FEATURES

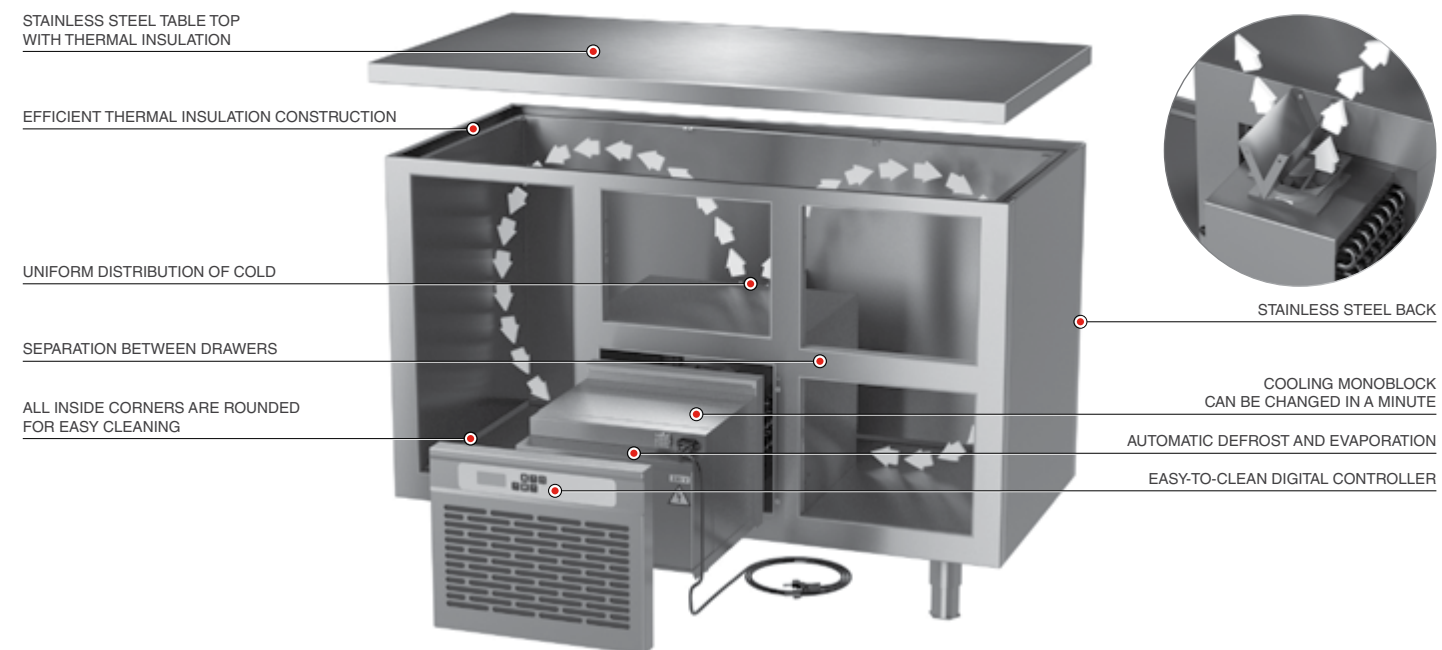

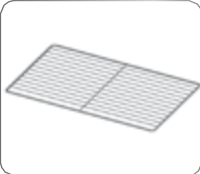
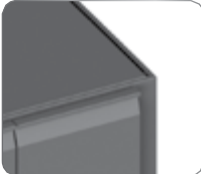
ACCESSORIES

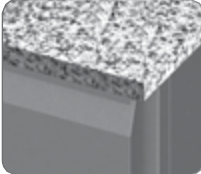
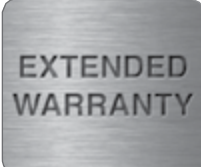
	Stainless steel grids Code: K-DMLG-530x325		Without table top Code: F00-000-10.00 SB
	Extra pair of stainless steel guides Code: F00-010-20.10		Granite table top: 30 mm thickness Code: MG
	Rear upstand for the table top Code: F00-000-12.00 SB		Extended warranty (covers replacing faulty parts) Code: Z-Service

 More technical information on last pages.
Customised equipment is available. Examples on last pages.