

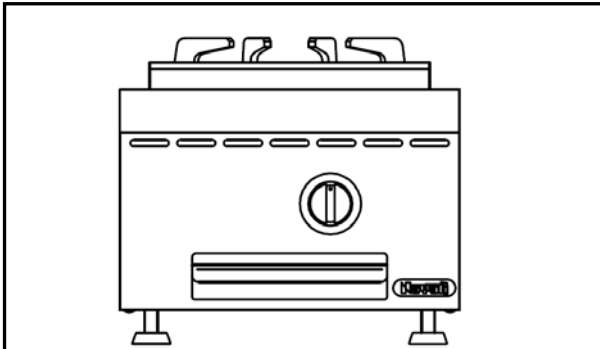

Total Food-Service Solutions

Modular Gas Wok Ring Table NGWT 3-55 SN, Gas Cooker with Wok Ring Adaptors

ITEM# _____
 MODEL# _____
 NAME# _____
 S/N# _____



*Due to routine technical improvement, the photograph shown may not represent the latest design of the products.

Amicus Modular Gas Wok Ring Table

Gas Cooker with Pan and Wok Ring Adaptors

NGWT 3-55 SN ONE GAS OPEN BURNER,
CAST IRON CAP,
WOK RING ADAPTORS

Short Form Specification

Item No. _____

Nayati Gas Wok Ring Table consists of one gas burner with 11.5 kW (G30) or 13 kW (G20) power rate, unit to be installed on open cabinet or similar elements, cantilever, or solid block solutions. Featuring rear seamless fitting to Amicus family products and unique removable seamless front panel.

Main Features

- Unit to be installed free standing, can be joined with base cabinet, table stand or cantilever system.
- Top panel and frontal body are unified but removable, so it is water protected and easy to service.
- Gas appliance supplied with G20 and G30/G31 components as standard.
- Gas system is equipped by safety device(thermocouple, failure function and gas filter)
- Iron Cast Wok Support to fit variety diameters of Wok Oil collecting drawer provided.

Construction

- All exterior panels in 304 type of Stainless Steel
- Orbital top panel anti-scratch finishing.
- Top and side are mounted by 1.2mm of Stainless Steel with pressed panel in side and front for solid construction.

Included Accessories

- G20 Conversion Kit.

Optional Accessories

- N/A

APPROVAL: _____

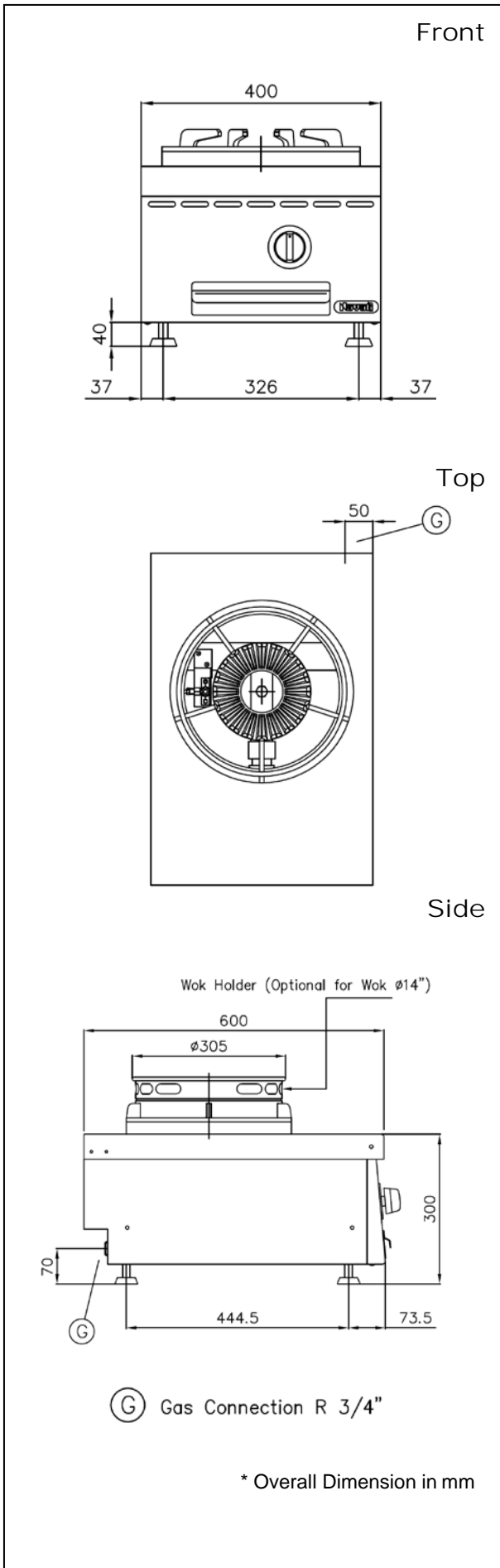

Gas

- Gas Power:** 11.5 kW (6,020 kCal/h)
13 kW (6,450 kCal/h)
- Gas Type Option:** G30/G31, G20
- Gas Inlet:** R 3/4"
- Natural Gas-Pressure:** G20: 20mbar
- LPG Gas Pressure:** G30/G31:
28-30mbar/37mbar

Key Information:

- Cooking Surface:** $\varnothing 330$ mm
- Working Temperature MIN:** -
- Working Temperature MAX:** -
- Direct heat emission:** -
- Latent heat emission:** -
- Steam emission:** -
- Net Weight:** 22.5 Kg
- Shipping Height:** 395 mm
- Shipping Width:** 450 mm
- Shipping Depth:** 700 mm
- Shipping Volume:** 0.087 m³

**Modular Gas Wok Ring Table
NGWT 3-55 SN, Gas Cooker
with Wok Ring Adaptors**

The company reserves the right to make modifications to the products without prior notice. All information correct at time of printing.

2016.03.08