



Total Food-Service Solutions

Modular Gas Euro Range NGER 13-70, Oriental and Western Cuisine Cooker with Two Gas Burners

ITEM#

MODEL#

NAME#

S/N#



*Due to routine technical improvement, the photograph shown may not represent the latest design of the products.

Oriental Modular Gas Euro Range with Two Gas Burners

NGER 13-70

DUAL FUNCTIONS:

1. PAN COOKING RING
2. WOK COOKING RING

SAFETY THERMOCOUPLE

Short Form Specification

Item No.

Modular Wok Super Range with Double Cooking Zone. Versatile as Open Burner, Pot Cooker, or Wok Open Burner. Higher Power Burner and Higher Splash Back compared to NGER 60 Series. Designed with only 700 mm depth. Constructed with deep drawn wok with cast iron of pot holder and combined with wok holder adapter. Dust Collection Drawer included below the front panel for hygiene cleaning operation. Compatible installation with others 70 Wok Super Range Series.

Main Features

- Gas Appliance supplied with G20 and G30/G31 components as standard.
- Gas system is equipped by safety device (thermocouple, failure function and gas filter).
- Iron Cast Wok Support to fit variety diameters of Wok Oil collecting drawer provided.
- Dual Functions (Pan Cooking Ring and Wok).
- Unit to be installed free standing.

Construction

- All exterior panels is constructed of Stainless Steel.
- Adjustable ± 25 mm Stainless Steel leg.
- Certified IPX4 protection.

Included Accessories

- Ignition Hand Lighter.
- Wok Holder.

Optional Accessories

- N/A.

APPROVAL:

Front

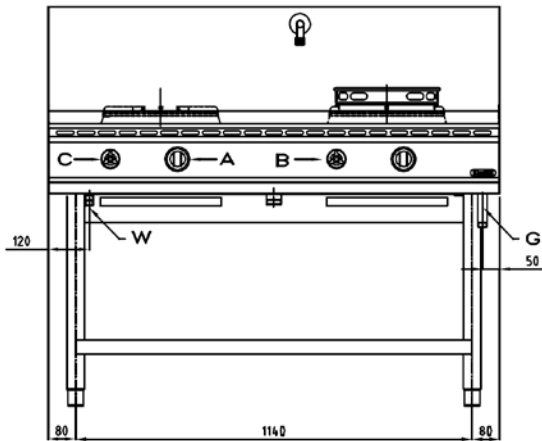

Top

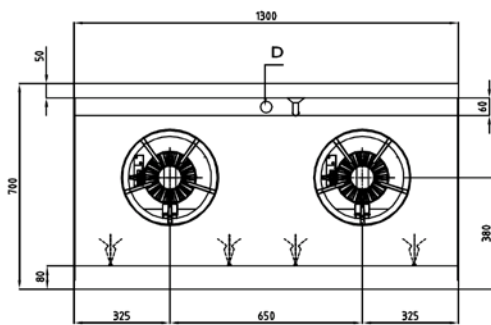

Side

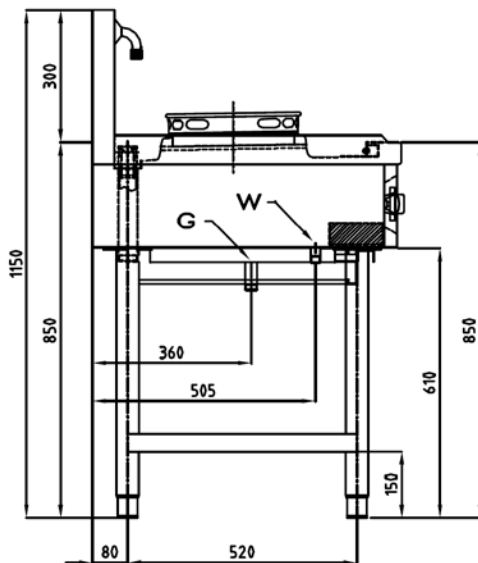

A = GAS VALVE BURNER
 B = WATER TAP FAUCET
 C = WATER TAP SPRAYER

* Overall Dimension in mm

Gas

Gas Consumption (G20): 26 kW (22,360 kCal/h)

Gas Consumption (G30): 23 kW (19,780 kCal/h)

Gas Type Option: G30/G31, G20

Gas Connection: 3/4"

Drain: 1 1/4"

Water Connection: 1/2"

LPG Gas Pressure: G20: 20mbar

G25: 20-25 mbar

G30/G31: 28-30/37mbar

G30/G31: 50mbar

Key Information:

Cooking Surface Wok: Ø 280 mm

Direct heat emission (G20): 6.50 kW

Direct heat emission (G30): 5.75 kW

Latent heat emission (G20): 2.60 kW

Latent heat emission (G30): 2.30 kW

Steam emission (G20): 3.82 kg /h

Steam emission (G30): 3.38 kg /h

Number of Burners: 2

Working Temperature MIN: -

Working Temperature MAX: -

Net Weight: -

Shipping Height: -

Shipping Width: -

Shipping Depth: -

Shipping Volume: -

*Missing information may be updated from time to time, please contact our representative to receive the updated data sheets.

**Modular Gas Euro Range
 NGER 13-70, Oriental and Western
 Cuisine Cooker with Two Gas Burners**

The company reserves the right to make modifications to the products without prior notice. All information correct at time of printing

2016.03.02

