

Glassfyller med dryppbrett

Produktnummer: 5GF-8P-WS

Glassfyller i forkrommet messing med dryppbrett i rustfritt stål med rist og drenering. Glassfylleren har mengderegulering og øyeblikkelig stopp ved fjerning av glasset.

Reservedeler:

- B-1255 Repsett for glassfyller

Tekniske data

- Størrelse dryppbrett: 321 x 270 mm
- Platetykkelse: 1,22 mm
- Høyde fra brett til utløp: 201 mm
- Anslutning: 1/2"

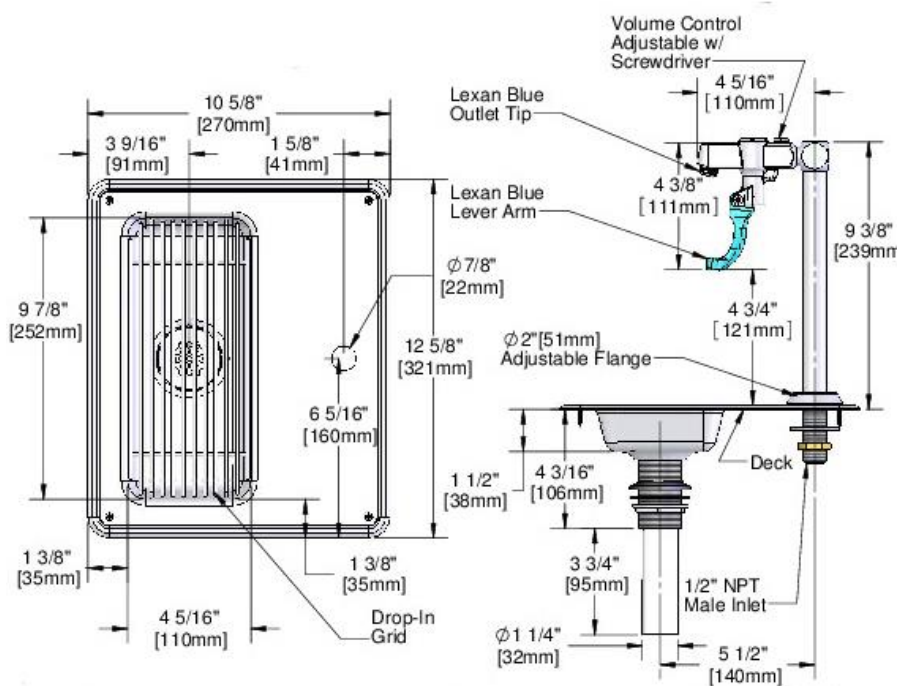



Architect/Engineering Specifications:

Deck mount water station with polished chrome plated brass pedestal type glass filler, adjustable flow outlet, push back actuation arm, pedestal with adjustable deck flange, 18 gauge stainless steel drip pan with drop-in grid and 1 1/4" drain. Certified to ASME A112.18.1/CSA B125.1, NSF 61-Section 9 and NSF 372. Meets ADA ANSI/ICC A117.1 requirements.

Job Name _____
 Model Specified _____ Quantity _____
 Variations Specified _____
 Date _____

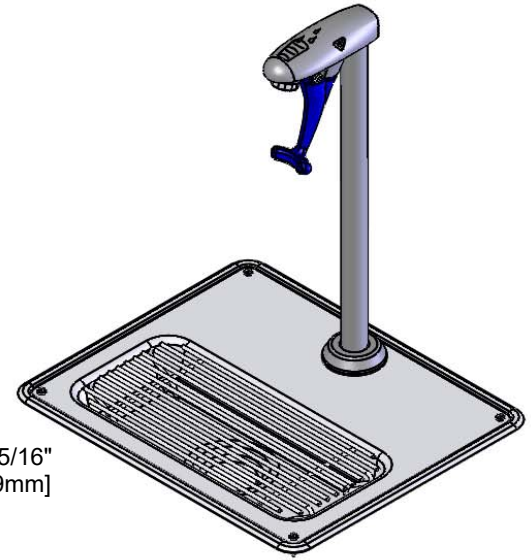
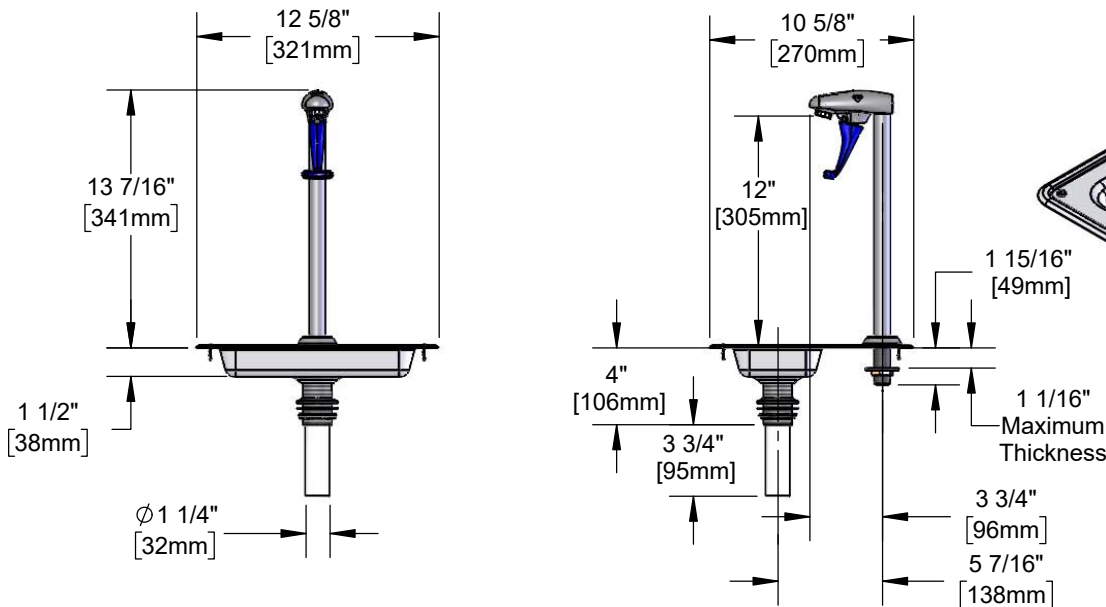

ADA Compliant

Features & Benefits:

- Deck mount water station
- 12" deck mount glass filler w/ polished chrome plated brass body
- Torx wrench adjustable flow outlet (wrench included)
- Dark blue push back arm
- Instantaneous shut-off
- 1/2" NPT male inlet
- Pedestal w/ adjustable ϕ 2" flange
- Drip pan w/ drop-in grid
- 1 1/4" drain
- Material: Polished chrome plated brass body & pedestal, chrome plated metal flange, stainless steel drip pan & grid and thermoplastic arm

Product Compliance:

- ASME A112.18.1 / CSA B125.1
- NSF 61 - Section 9
- NSF 372 (Low Lead Content)
- ANSI A117.1 (ADA)

Warranty: One Year (Limited)

Performance Data:

- Pressure: 20 - 125 psi
- Temperature: 40°F - 140°F
- Flow Rate: 0.25 GPM min @ 60 psi
2.25 GPM max @ 60 psi
- Discharge Rate: 18.00 GPM max





T&S BRASS AND BRONZE WORKS, INC.
 2 Saddleback Cove / P.O. Box 1088
 Travelers Rest, SC 29690

Model No.
B-1230-12

Item No.

Travelers Rest, SC: 800-476-4103 • Simi Valley, CA: 800-423-0150 • Fax: 864-834-3518 • www.tsbrass.com

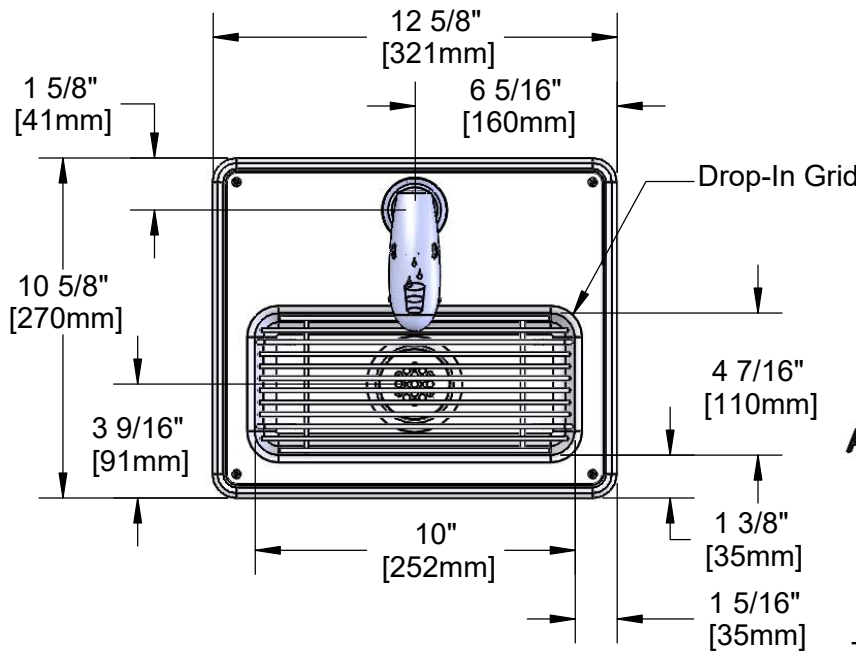

This Space for Architect/Engineer Approval

Job Name _____ Date _____

Model Specified _____ Quantity _____

Customer/Wholesaler _____

Contractor _____

Architect/Engineer _____



ADA Compliant

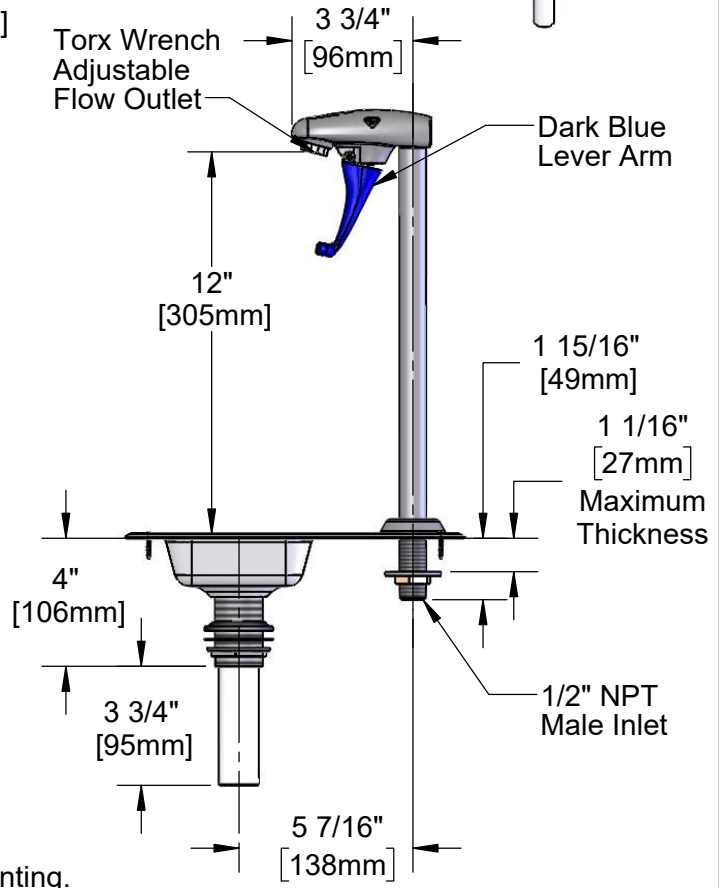
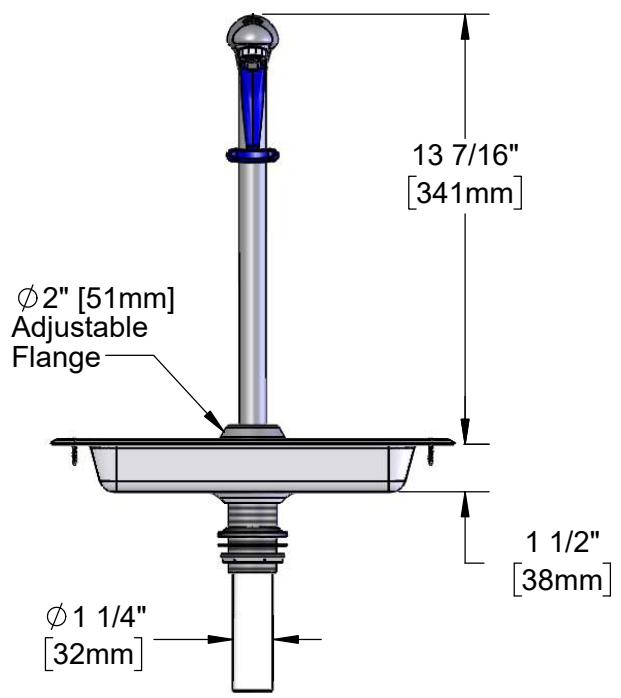

- Note:
- 18 Gauge Stainless Steel Pan w/ Beaded Edge
 Supplied w/ Mastic & Stainless Steel Screws for Mounting.
 - Suggested Cut-Out Size for Pan is 10-1/2" x 5". Customer to Verify Actual Cut Out Needed Prior to Installation.

Product Specifications:
 Deck Mount Station w/ Pedestal Type Glass Filler, 18 Gauge Stainless Steel Drip Pan & 1 1/4" Drain

Product Compliance:
 ASME A112.18.1 / CSA B125.1
 NSF 61 - Section 9
 NSF 372 (Low Lead Content)
 ANSI A117.1 (ADA)