

NEO 42XL

VACUUM PACKAGING MACHINE



DESCRIPTION

Neo 42XL represents advanced vacuum packaging technology with additional functionality because of the VacAssist app. Standard equipped with a Busch vacuum pump, Touch control with sensor and special marinating and packaging functions. This table-top model complies with CE standards.



Henkelman offers standard 3 year warranty.

FEATURES

- Standard with 1 seal bar (front): 420 mm
- Standard double seal (two wires). Optional without extra costs: Cut-off/Wide seal
- Seal bars easily removable for cleaning and maintenance purposes
- Pump capacity: 21 m³/h Busch vacuum pump
- Pump maintenance and cleaning program
- Machine cycle: 15-35 sec
- Standard Sensor control: max. 99.8%, for an optimum and consistent vacuum cycle
- Soft Air to protect the product and vacuum bag
- Standard Touch control panel with 20 program memory and Sensor control
- Deep drawn stainless steel vacuum chamber welded to the chassis for more hygiene
- Stainless steel exterior with round edges
- Improved construction of the hinge system: one integrated unit of gas and torsion springs
- New design of transparent lid
- Comes with insert plate for a faster cycle and product adjustment
- VacAssist app for more operational and programming possibilities, available for free in App Store and Google Play Store
- Bluetooth module

OPTIONS

- 2nd seal bar (front-back)
- 1-2 Cut-off seal
- Liquid control
- Gas flush

ACCESSORIES

- Zebra ZD410 thermal label printer
- Inclined insert plate (for packing liquids)
- Food container adaptor
- Service kit for standard maintenance
- Trolley with shelves

VACUUM PACAGING MACHINE NEO 42XL – SPECS

DIMENSIONS

In mm

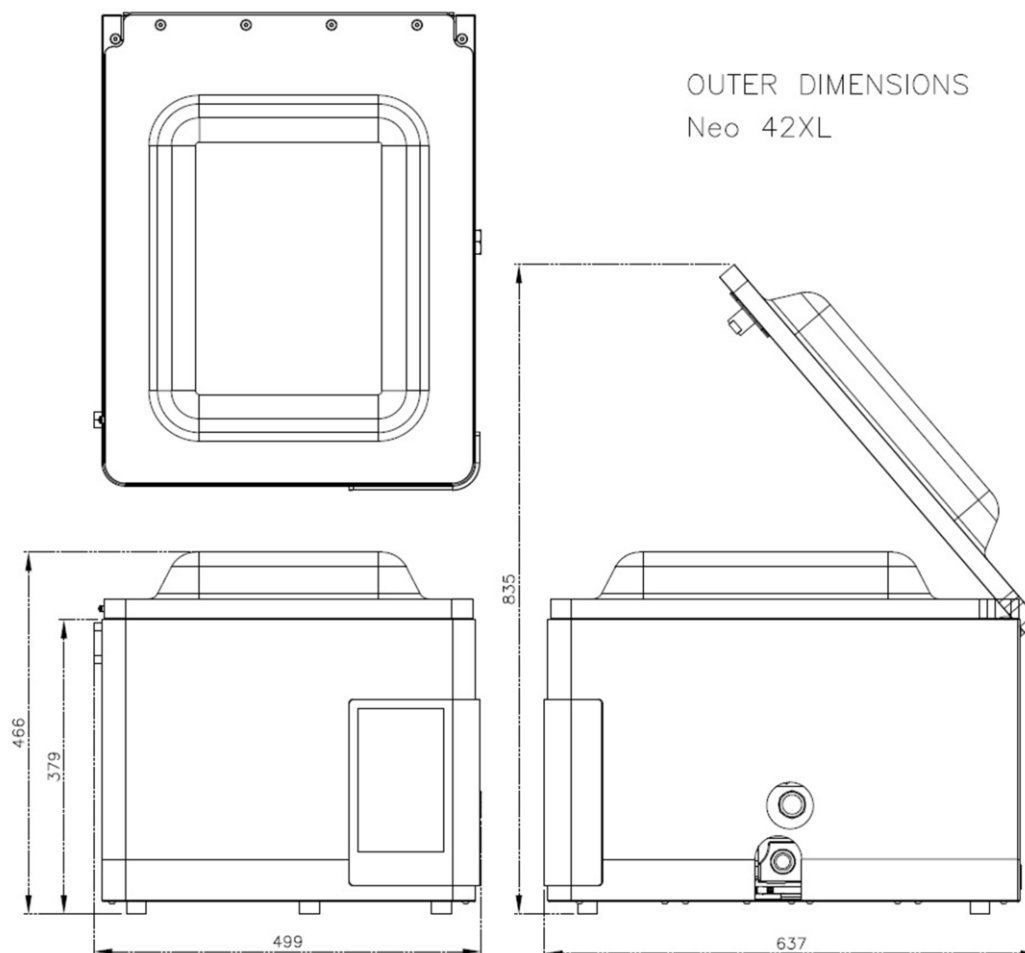

Model	Dimensions (mm)		Voltage* (Hz)	Pump capacity (m ³ /h)	Power (kW)	Weight (kg)
	Chamber (usable space) L x W x H	Machine L x W x H				
Neo 42XL	460 x 420 x 180	637 x 499 x 466	230V-1-50	21	0,75 - 1,0	72

* Other voltages available



HENKELMAN BV
Titaniumlaan 10
5221 CK 's-Hertogenbosch
The Netherlands

Sales support
P +31 73 621 36 71
E info@henkelman.com
Service/technical support
P +31 73 621 36 71
E service@henkelman.com