



Project _____
 Item # _____
 Quantity _____

Therm-Max® Salamander

Models: TMS-1, TMS-1H

Hatco's Therm-Max® Salamander is specially designed for versatility in the kitchen with the capabilities to cook, grill and reheat food. The unparalleled start up speed is a result of "instant on" heating elements located in the upper housing of the salamander. Therm-Max Salamander is energy efficient and easy to operate.

Standard features

- The high-powered heating elements are ready for use within eight seconds
- Two independently-controlled heating element sections give the benefits of flexibility and energy conservation
- Cook mode selection switch controls left, right, or both locations
- Made of stainless steel for easy cleaning and durability
- The Salamander can be placed on a countertop or mounted to a brick or cement wall
- The TMS-1H includes a hold mode switch that reduces power to 25% and keeps food at proper serving temperatures
- Units come standard with grill, drip pan and wallmounting bracket



*TMS-1H
 moveable upper housing to
 reduce the transfer of heat
 to surrounding areas while
 precisely positioning heat
 over food product*

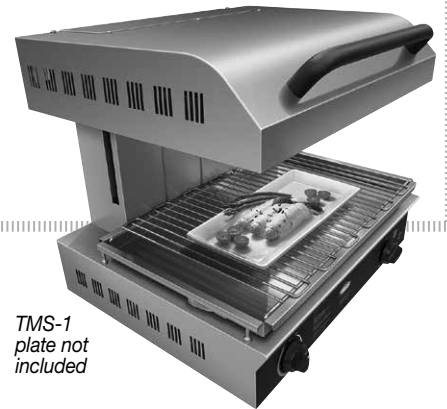

*TMS-1
 plate not
 included*



HATCO CORPORATION | P.O. Box 340500 Milwaukee, WI 53234-0500 U.S.A. | (800) 558-0607 | (414) 671-6350

Fax: (800) 543-7521 | Int'l. Fax: (414) 671-3976 | www.hatcocorp.com | equipsales@hatcocorp.com or intl@hatcocorp.com



Therm-Max® Salamander

Models: TMS-1, TMS-1H

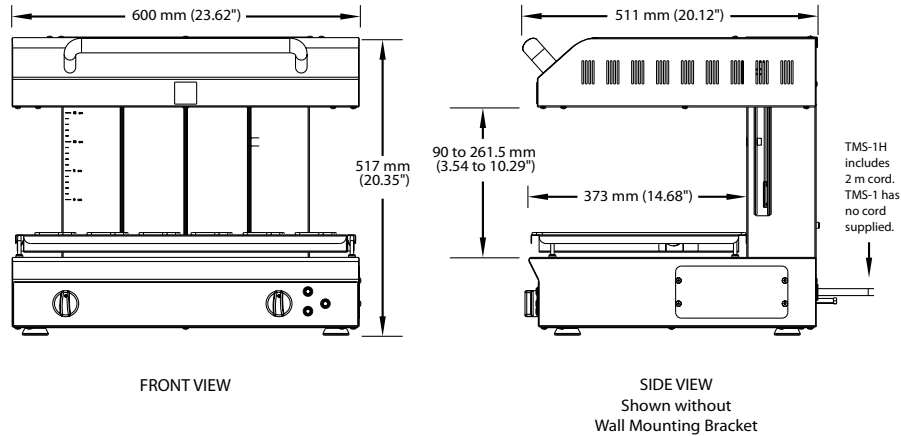

SPECIFICATIONS

Therm-Max®

The shaded areas contain electrical information for International models

Model	Dimensions (Width x Depth x Height)	Cooking Area (Width x Depth x Height)	Hertz	Volts	Phase	Watts	Amps	Plug	Power Location	Ship Weight†
TMS-1	600 x 511 x 517 mm (23.62" x 20.12" x 20.35")	(540 x 373 x 90-261 m) (21.25" x 14.68" x 3.54-10.29")	50/60	230/400	Three	4000	8.7	No cord†	Right side of back, near bottom	70 kg (155 lbs.)
			50/60	230	Single		17.4			
TMS-1H	600 x 511 x 517 mm (23.62" x 20.12" x 20.35")	(540 x 373 x 90-261 m) (21.25" x 14.68" x 3.54-10.29")	50/60	230	Single	4000	17.4	None†	Right side of back, near bottom	70 kg (155 lbs.)

* Shipping weight includes packaging.
 † Power cord is attached without a plug

PRODUCT SPECS

THERM-MAX®

The Salamander shall be a Therm-Max® Model ..., rated at ... watts, ... volts, single or three phase and be ... millimeters in overall width.
 The Salamander shall consist of stainless steel housing with two cook zones.

The upper housing, that contains instant-on infrared heating elements, shall be movable from ... millimeters to ... millimeters. The Salamander shall be factory assembled with mounting hardware, ready for electrical installation only.

HATCO CORPORATION | P.O. Box 340500 Milwaukee, WI 53234-0500 U.S.A. | (800) 558-0607 | (414) 671-6350

Fax: (800) 543-7521 | Int'l. Fax: (414) 671-3976 | www.hatcocorp.com | equipsales@hatcocorp.com or intl@hatcocorp.com