



Client \_\_\_\_\_ Quantity \_\_\_\_\_  
 Project \_\_\_\_\_ Posizione \_\_\_\_\_

## Master 1400 lt cabinet

**Model:** A140/2M

**Cod:** A14140200201

Armadio refrigerato Master 1400 litri Plug-In, 2 porte con maniglia inox, classe energetica B, classe climatica 5 heavy duty e gas refrigerante ecologico R290. Serratura con chiave, illuminazione, completo di 3 griglie plastificate GN2/1. Range di temperatura -2°+8°C; refrigerazione ventilata. Evaporatore trattato anticorrosione. Struttura monoscocca con isolamento 75 mm. Interno/esterno in acciaio inox AISI 304; schiena esterna, fondo esterno e interno vano tecnico in acciaio galvanizzato/colaminato. Sistema refrigerante sostituibile FSS - Fast Service System - per un service facile e veloce. Predisposto per

### Dati tecnici

<b>Gross capacity:</b>	1356 lt
<b>Temperature range:</b>	-2°+8°C
<b>Refrigerant unit:</b>	Plug-In
<b>Energetic class:</b>	B
<b>Energy efficiency index:</b>	31,6
<b>Annual consumption:</b>	659
<b>24h consumption:</b>	1,81
<b>Climate class:</b>	5
<b>Cooling gas:</b>	R290
<b>Defrost:</b>	Hot gas
<b>Valve:</b>	Supplied standard with solenoid
<b>Dimensions:</b>	1480×815×2085 mm
<b>Packing dimensions:</b>	1575×930×2250 mm
<b>Gross weight:</b>	210 Kg
<b>Voltage:</b>	220-240 V - 50 Hz
<b>Electric power:</b>	260 W
<b>Total rate:</b>	1,2 A
<b>Resa:</b>	533 W
<b>Cooling capacity:</b>	Evap. -10°C Cond. +55°C

### Features

<b>Standard equipment:</b>	6 slides for GN2/1 shelves, 6 plastic coated GN2/1 shelves, lock with key, LED lighting
<b>Control:</b>	Electronic, display flush with the panel
<b>Doors:</b>	1 door, self-closing with a 105° stop, right hinged
<b>Door gasket:</b>	Magnetic, triple chamber and easily replaceable
<b>Insulation:</b>	75 mm thickness - CFC/HCFC free
<b>Exterior/interior finishing:</b>	Exterior and interior AISI 304 stainless steel. Back, base and internal technical compartment in galvanized/colaminated steel.
<b>Inner corners:</b>	Rounded for easy cleaning and ensuring maximum hygiene
<b>Handle:</b>	Stainless steel AISI 304, 2 mm thick
<b>Racks and slides:</b>	Stainless steel AISI 304
<b>Feets:</b>	Stainless steel AISI 304, adjustable h 100-150 mm

**COSMO - wi-fi control**

Cosmo è l'innovativa tecnologia wi-fi che permette di connettere tra loro tutti gli apparecchi Coldline presenti in cucina e di monitorarli costantemente dal tuo smartphone. Collega gli armadi Master ad un Cosmo hub (MODI, VISION o LEVTRONIC) e dall'app potrai controllare in tempo reale le condizioni di funzionamento di ogni macchina e ricevere eventuali alert in caso di interruzioni della rete elettrica o interventi impropri del personale.



**Technical draw**

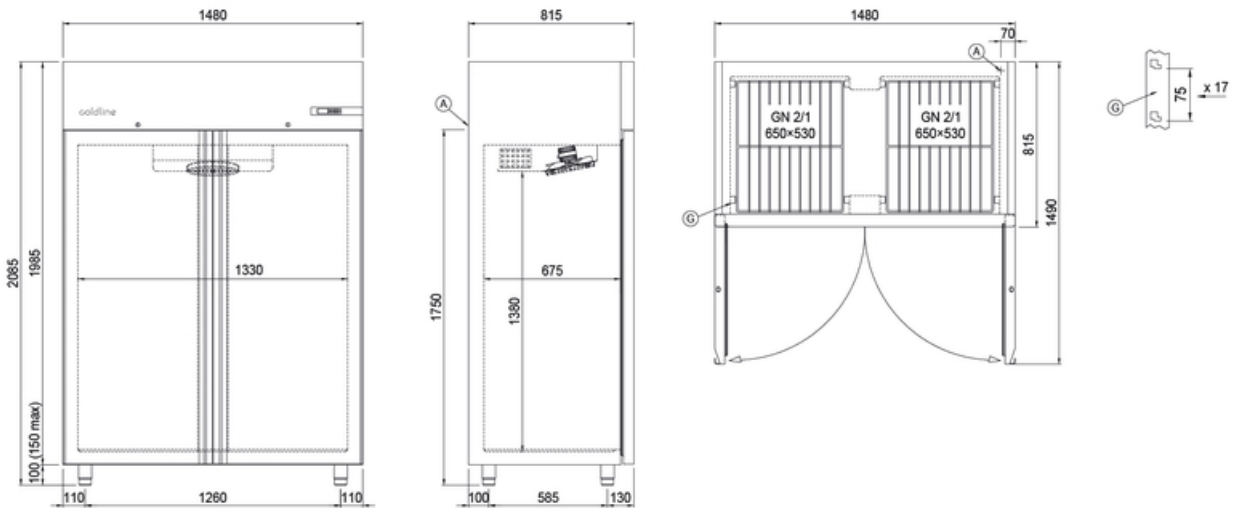

**A:** Power supply cable outlet

**D:** Airflow conveyor

**G:** Racks pitch

In order to constantly offer the best possible products we reserve the right to make changes on technical specifications without incurring any obligation for equipment previously or subsequently sold.