



SHAHI TANDOOR[®] - DELUXE

- *Stylishly contoured design*
- *“Easy clean” moulded top surface allows unit to sit flush against rear wall*
- *Low operation cost due to efficient insulation between clay pot and stainless steel frame*
- *Inner pot made with special in-house clay mix for maximum thermal shock*
- *Unit is mobile with heavy duty swivel castor wheels*
- *Available in natural gas or LPG (bottled gas)*



The Clay Oven Co. Ltd.
163 Dukes Road, London W3 0SL
Tel: +44 (0) 208 896 2696 Fax: +44 (0) 208 896 2686
www.clayovens.com



TECHNICAL DATA

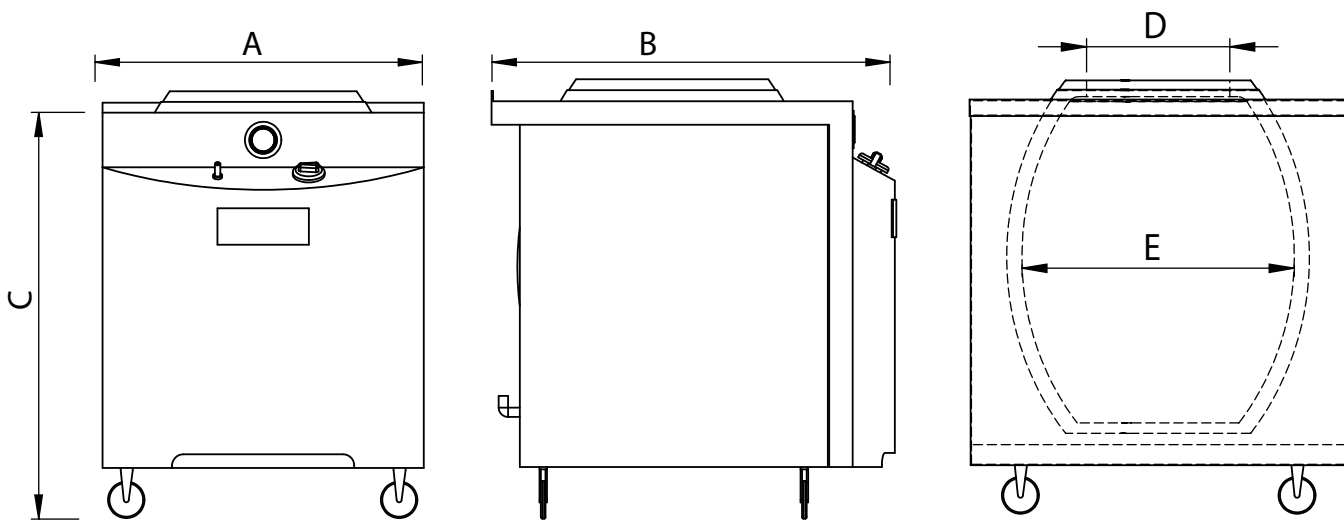

	A	B	C	D	E	WGT
SIZE ONE	24" 600mm	27.5" 700mm	36" 920mm	10" 255mm	20" 500mm	280lbs 130kgs
SIZE TWO	28" 715mm	32.5" 825mm	35" 890mm	13.5" v	25" 630mm	360lbs 165kg
SIZE THREE	32" 810mm	36" 910mm	35" 890mm	14.5" 370mm	27" 690mm	400lbs 185kg

	Natural Gas	Propane Gas
Heat Input (size 1/2)	10kw (net) 35000Btu	10kw (net)
Heat Input (size 3)	14kw (net) 45000Btu	14kw (net)
Gas Supply Pressure	20 mbar	37mbar
Burner Pressure (High rate:)	15-16 mbar	35-36 mbar
Burner Pressure (Low rate)	Low rate: 6-7mbar	26-27 mbar
Gas Rate	0.95 m ³ /hour	0.72 kg /hour

Cooking rods and a stainless steel lid are provided

Continuous product improvement is a policy of the Clay Oven Co. Ltd therefore specification and design are subject to change without notice.

Please note: The inner clay pot is made from naturally sourced material and variations of shrinkage might occur. Fissures may appear on the surface, but these will not impede the cooking ability of the oven. A kit with full instructions is provided for routine maintenance.



The Clay Oven Co. Ltd.

163 Dukes Road, London W3 0SL

Tel: +44 (0) 208 896 2696 Fax: +44 (0) 208 896 2686

www.clayovens.com