

Fact Sheet

iL Professional 50/150 SPM/SP

BIZERBA

The load receptor for perfect hygiene ... the ergonomic iL Professional 50/150 SPM/SP has been designed to meet the hygienic design requirements of EHEDG. This ensures easy cleaning as well as increased hygiene and safety. Perfect for use in the foodstuffs or pharmaceutical industry.



More information
High performance
with a wide range of
solutions and options.

Specifications	Facts	Details
Weighing ranges	from 3 kg to 150 kg	interval from 1 to 50 g
Load cell	stainless steel load cells	
Dimensions of load platter	335 x 260 mm 500 x 400 mm 600 x 450 mm	
Materials	load carrier, load platter and feet	stainless steel 1.4301, electro-polished
Overall height	Height 103 mm Height 145 mm Height 145 mm	Dimension 335 x 260 mm Dimension 500 x 400 mm Dimension 600 x 450 mm
Mounting method	free-standing	table / floor mount, with / without stand
Protection type	IP69	for load receptor and terminal
Ex version	zone 1/21 zone 2/22	load cells in Ex-ib version for Ex zones 1&21 as well as 2&22 possible
Ambient temperature	Operation: -10 °C to +40 °C Storage: -50 °C to +85 °C	

Options	Facts	Details
Stand	stand on load receptor stand on load receptor stand on load receptor	swivable terminal / swivable mount for terminals ST, iS30 and iS50 fixed terminal / mount for terminals iS10 and iS20 swivable terminal / swivable mount for terminal iS10 and iS20
Cable connection	load cell cable with connector	measuring cable with connector
Bench	height 550 mm - 565 mm stainless steel 1.4301, electro-polished feet in hygienic design	for dimensions 500 x 400 mm and 600 x 450 mm

Infographic

Weighing range	Metrologically approved interval	Dimensions	Load cell	max. Preload	Variant			
					Complete stainless steel	Galvanized steel / stainless steel	EX	
3 kg	1 g	335 x 260 mm	PW15	2 kg	X		X	
6 kg	2 g			8 kg	X		X	
15 kg	5 g			14 kg	X		X	
30 kg	10 g			14 kg	X		X	
6/15 kg multi-range scale	2/5 g			0 kg	X		X	
15/30 kg multi-range scale	5/10 g			14 kg	X		X	
15 kg	5 g	500 x 400 mm	PCB	15 kg	X		X	
30 kg	10 g			50 kg	X		X	
60 kg	20 g			70 kg	X		X	
150 kg	50 g			70 kg	X		X	
15/30 kg multi-range scale	5/10 g			600 x 450 mm	50 kg	X		X
30/60 kg multi-range scale	10/20 g				18 kg	X		X
60/150 kg multi-range scale	20/50 g		70 kg	X		X		

Symbols



Protection class IP69



Ex-Zone 1/21



Ex-Zone 2/22



Single point



DMS load cell



EHEDG



Hygienic design



Table



Stainless steel

Dimensions

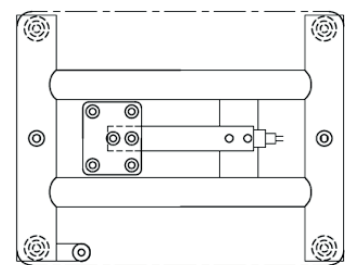
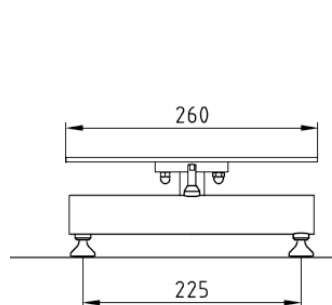
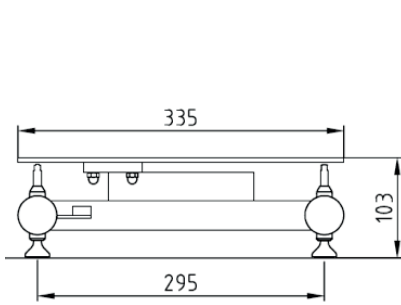

iL Professional 50SPM/SP

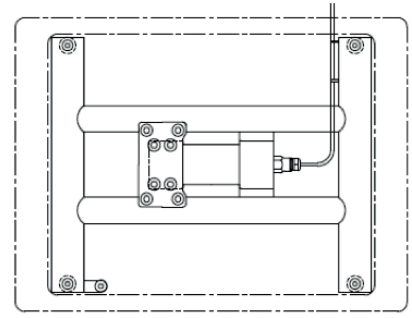
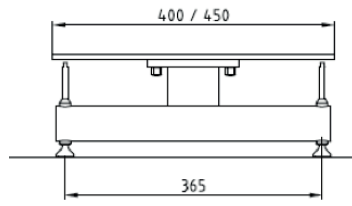
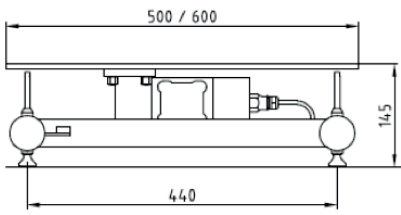

iL Professional 150SPM/SP

Load plate dimensions: 500 x 400 mm,

600 x 450 mm

Bizerba GmbH & Co. KG

Wilhelm-Kraut-Straße 65
72336 Balingen
Germany
T +49 7433 12-0
F +49 7433 12-2696
marketing@bizerba.com

www.bizerba.com