

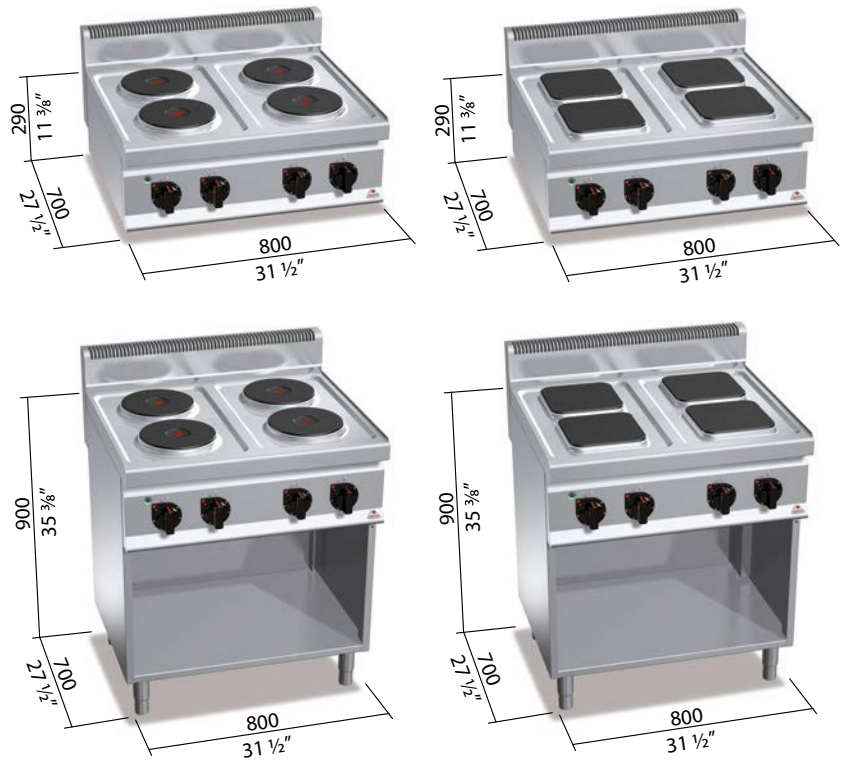

| | | |
|--|---------|---------|
| | n. | 4 |
| | Ø mm | 220 |
| | kW | 2,6 |
| | n. | 4 |
| | mm | 220x220 |
| | kW | 2,6 |
| | 230V 3 | |
| | TOT. kW | 10,4 |

OPTIONAL
 2P 400 Doors with 10 thickness for cabinet versions
 pressed handle of 20/
 20/10 für Modelle mit Möbel
 V3/B Volts 220 - 240-3



E connessione elettrica / electric connection /
 branchement électrique / Elektrischer Anschluss 230V 3 kW 10,4

TECHNICAL AND FUNCTIONAL FEATURES

Worktop and front panels of AISI 304 stainless steel. One piece pressed waterproof worktop. Cast iron plates with safety thermostat and 6-position selector that activates 6 different concentric power zones. Voltage light and power light. Adjustable feet (cabinet version).

