

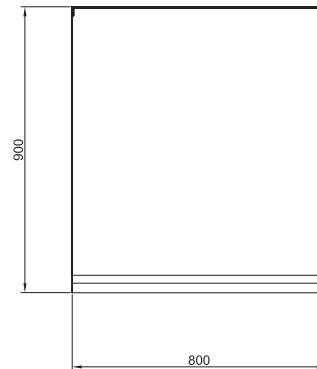

cm² | 6960

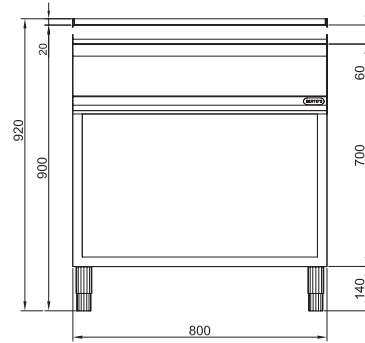

Kg | 58

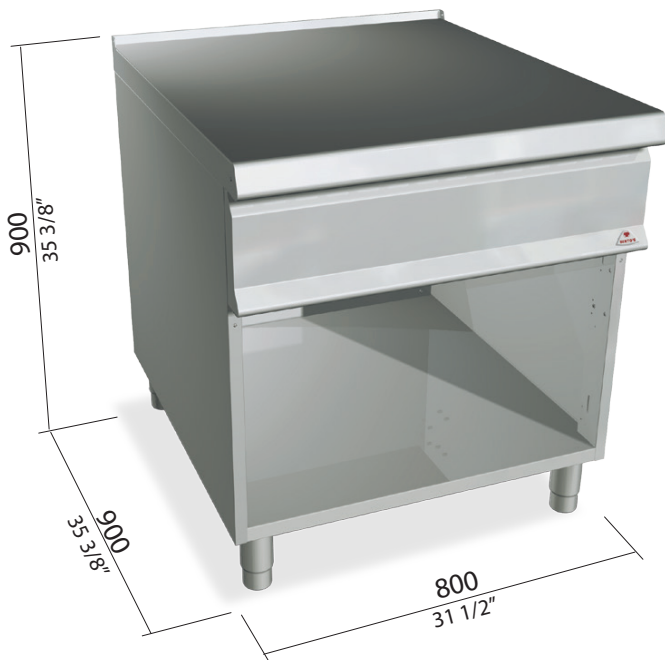

OPTIONAL

S2P 400 n. 2 PORTE - n. 2 DOORS - n. 2 PORTES - n. 2 TÜREN

CARATTERISTICHE TECNICHE E FUNZIONALI

Piano di lavoro in acciaio inox AISI 304 con spessore 20/10, pannelli frontali e laterali in acciaio inox AISI 304, con finitura Scotch Brite.
Ampio vano completamente in acciaio.

TECHNICAL AND FUNCTIONAL FEATURES

Worktop from AISI 304 stainless steel of 20/10 thickness, front and side panels from AISI 304 stainless steel and Scotch Brite finishing.
Large compartment completely in steel.

CARACTÉRISTIQUES TECHNIQUES ET FONCTIONNELLES

Plan de travail en acier inoxydable AISI 304 avec une épaisseur de 20/10, panneaux avant et latéraux en acier inoxydable AISI 304, finition Scotch Brite.
Grand compartiment complètement en acier.

TECHNISCHE UND FUNKTIONELLE EIGENSCHAFTEN

Arbeitstisch aus rostfreiem Edelstahl AISI 304, Stärke 20/10, Vorder- und Seitenwände aus rostfreiem Edelstahl AISI 304, Ausführung Scotch Brite.
Großer Unterbau, komplett aus Stahl.