



cm² | 3.300 (mm710x465)



V | 230V 3



Kw | 9,6



Kg | 80

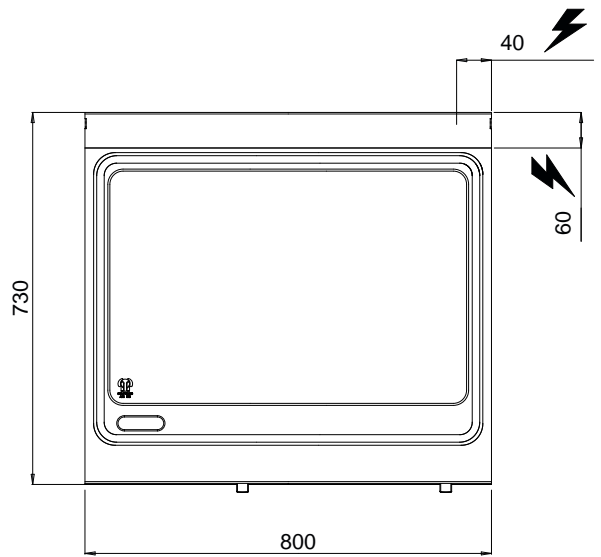
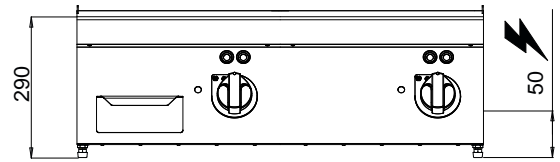

OPTIONAL
 7PSFT80 PARASPRUZZI / SPLASHGUARD / ECRAN ANTI-ÉCLABOUSSURES / SPRITZSCHUTZ
 TPTO TAPPO IN TEFLON / TEFLON STOPPER / BOUCHON DE TEFLON / TEFLONPFROPFEN



TECHNICAL AND FUNCTIONAL FEATURES

Worktop in AISI 304 stainless steel of 20/10 thickness, front and side panels in AISI 304 stainless steel, Scotch Brite finishing. Incoloy steel heating elements positioned beneath the cooking plate. Thermostatic control and safety thermostat with manual restart. Temperature regulation from 50 °C to 300 °C. Power indicator and temperature light. Very thick smooth built-in plate with rounded edges and a peripheral drain along the plate to collect food residue. Two cooking zones with independent temperature controls. Dual-component cooking plate comprising of a steel plate to optimize cooking evenness and an upper coat in AISI 316 stainless steel with a bright finishing; easy to clean and low level of heat irradiation to guarantee higher comfort to the operator. Large drain hole and a line to the watertight drain pan.