

# User Manual

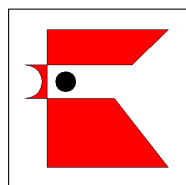

CE

**Giant Pan Counter and Stand Unit  
electrically heated**



**ubert®**



# 1 Contents

1	Contents .....	3
2	Important References .....	4
2.1	Fundamental Safety Notes .....	4
2.2	Warranty and Liabilities .....	5
2.3	Symbols and Notes .....	5
2.4	Copyright .....	5
2.5	Special safety references .....	6
3	Technical details .....	8
3.1	Dimensions [mm] .....	8
4	Installation and putting into operation .....	11
4.1	Unwrapping .....	11
4.2	Installation .....	11
4.3	Electrical connection .....	11
4.4	Preparation of Using / Starting up .....	12
5	Operation .....	13
5.1	Operation elements .....	13
6	Maintenance .....	14
6.1	Cleaning and care .....	14
6.2	Trouble shooting .....	15
6.3	Wiring Diagrams .....	16
6.4	Spare Parts .....	18
6.5	PF ET Declaration Of Conformity .....	19
6.6	PF ES Declaration Of Conformity .....	20

## 2 Important References

### 2.1 Fundamental Safety Notes

#### 2.1.1 Consider notes in the operating manual

Precondition for the safe and trouble free use of this unit is the knowledge of the fundamental safety notes and safety regulations.

The operating instruction contains the most important references to operate the unit safely.

This operating instruction, particularly the safety references, are to be considered by all persons, who work on the unit.

Furthermore the rules and regulations to avoid accidents are to be considered.

#### 2.1.2 Obligation of the operator

The Operator is obliged to only let persons work with the unit who:

- are familiar with the fundamental regulations of work safety and accident avoiding and who have been instructed how to operate the unit.
- read and understood the chapter about safety and warning notes and have confirmed this with their signature.

The safe conscious operation of the personnel has to be examined regularly.

#### 2.1.3 Obligation of the personnel

All individuals who are authorized to work with the unit are obliged to:

- pay attention to the fundamental regulations of work safety and accident avoiding,
- read the chapter on work safety and warning notes in this manual and to confirm through their signature that they have understood these, before actually operating the unit.

#### 2.1.4 Possible risks

Pan Units are built state of the art and in acknowledgement of all safety related rules. Nevertheless is it possible that danger for body and lifes of the user and/or third and/or impairments at the unit or at other real values merge. The unit is to be used only :

- for the due use.
- in safety related flawless condition.

Disturbances which can hurt the safety are to be eliminated immediately.

#### 2.1.5 Due use

The Giant Pan Counter and Stand Units are only heating sources for preparing food in pans (e.g. an Ubert-Giant Pan). Any other use of the unit are only allowed after consulting UBERT GASTROTECHNIK GMBH. Damages which result out of wrong use UBERT GASTROTECHNIK GMBH cannot be held responsible. Part of the due use is also:

- the consideration of all references of the operating manual and the observance of necessary maintenance and service.

## 2.2 Warranty and Liabilities

Fundamentally our "General terms of sale and delivery" count. These are known to the operator at the latest since signing of the contract. Claims to warranty and liability at persons- and property damages are impossible, if they are to be led back to one or several of the following causes:

- Non due use of the unit.
- Improper assembling, starting up, operating and servicing of the unit.
- Operating the unit with defective safety devices or safety devices which have not been installed properly and are in no working condition.
- Disobeyment of the references in the operating manual concerning transportation storage, installation, start-up, operation, maintenance and assembling of the unit.
- Unauthorized mechanical or electrical changes of the unit.
- Unsufficient maintenance of wear and tear parts.
- Unauthorized repair.
- Force of nature and act of god.

## 2.3 Symbols and Notes

In the operating manual the following symbols and signs are used:



This symbol means a possibly or directly threatening danger for the life and the health of persons and/or a possibly dangerous situation.  
*Ignoring of these references may result in consequences for your health and/or can lead to property damages !*



This symbol points to important references for the proper use of the unit.  
*Not paying attention to these references can lead to disturbances at the unit or in the environment !*



This symbol points to operation tips and especially useful information.  
*Help to use all functions at your unit optimally*

## 2.4 Copyright

The copyright on this operating manual remains at the company UBERT GASTROTECHNIK GMBH This operating manual is intended only for the operator and his personal. It contains instructions and references wich neither completely nor partially:

- be duplicated
- be circulated or
- be otherwise made available to third parties.

Offences may violate applicable laws.



## 2.5 Special safety references

### 2.5.1 Safety devices

- Before operating the unit all protective devices as well as all removable parts must be installed correctly and be fully workable.
- Protective devices may only be removed:
  - after stand still and
  - prevention of unintentional restart.
  - If partial components are delivered, an authorized staff member or service technician has to execute assembly according to installation guidelines.

### 2.5.2 Informal safety steps

- The operating manual is to be kept constantly accessible in the operating area.
- In addition to the operating manual all generally acknowledged and all local regulations for accident avoiding and environmental protection have to be applied with.
- All safety- danger labels at the unit are to be kept in readable condition.

### 2.5.3 Education of the personal

- Only trained and instructed personal may work at the unit.
- The responsibilities of the personal are to be determined clearly for installing, start-up, operation, assembling, and servicing of the unit.
- During instruction the personal may only work at the unit under supervision of an experienced person.

### 2.5.4 Unit-control

- Only instructed personal is allowed to operate the controls.

### 2.5.5 Safety during regular operation

- The unit is only to operate if all protective devices are fully workable.
- At least once per shift the unit is to be examined with regard to visible damages and functional ability of the safety devices.

### 2.5.6 Dangers caused by electric energy

- Any work on the electrical supply is to be executed only by a specialist.
- Likewise the electrical connection of this unit to the power supply must be executed by an electro-specialist. (only Stand Units)
- The connection must follow the rules of the local determinations.
- The electric installation is to be examined regularly. Loose connections and brased cables are to be eliminated immediately.
- If works at any life-parts are necessary, a second person who switches off the main switch if necessary is to consult.

### 2.5.7 Special danger-spots

- Do not touch the hot heating elements! Danger of burning!

### **2.5.8 Service and maintenance, troubleshooting**

- Prescribed adjustment, service and inspection work is to be accomplished timely by the manager or if necessary by an authorized service technician.
- The operating personal is to be informed before the beginning of the maintenance and service work.
- The unit is to be disconnected from the mains before maintaining, inspecting and repairing is performed; the main switch is to be guarded against unintended reclosing. (only Stand Units)
- Pull out the plug before maintaining, inspecting and repairing is performed. (only Counter Units)
- Check all screw connections for tight fitting.
- After finishing maintenance check all safety devices for proper functionality.

### **2.5.9 Structural changes to the unit**

- Do not perform any changes, extensions or conversions to the unit without the manufacturers permission, especially welding work at supporting parts.
- For all conversions a written permission of the company UBERT GASTROTECHNIK GMBH is necessary.
- Change all parts of the unit, that are in improper condition.
- Use only original spare parts.

### **2.5.10 Cleaning of the unit and disposal of the waste**

Used substances and materials are to be handled and disposed appropriately, especially lubricants. Detergents have to follow the rules of food-hygiene.

### 3 Technical details

#### 3.1 Dimensions [mm]

##### PF600TGE

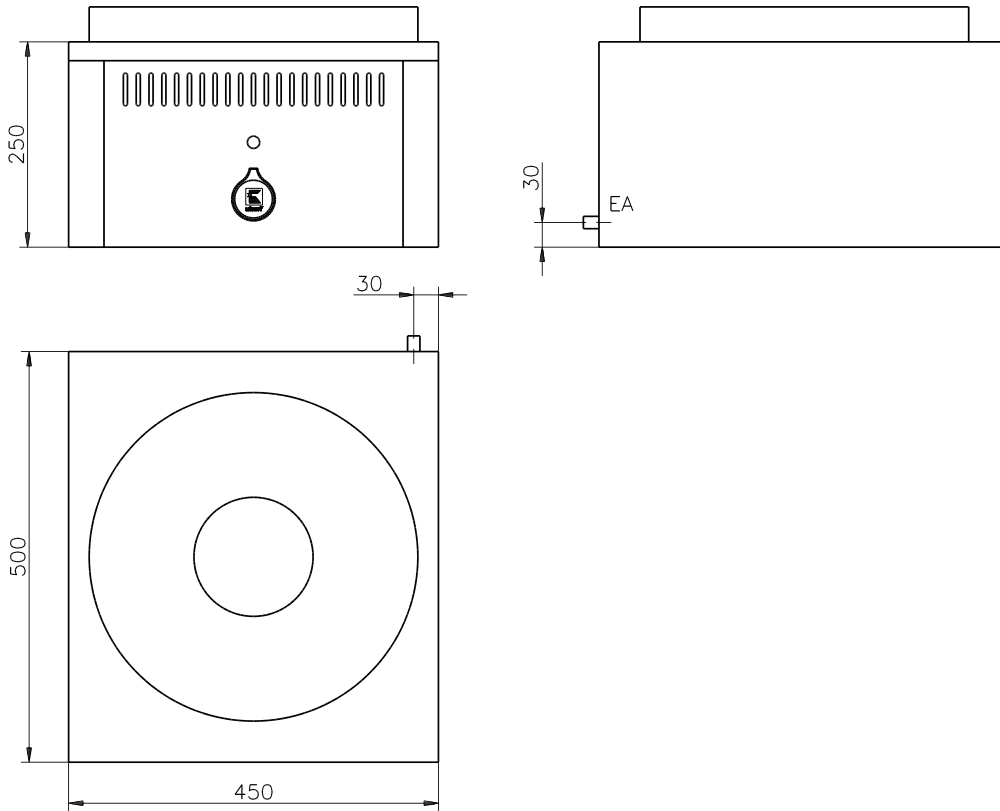

##### PF860TGE

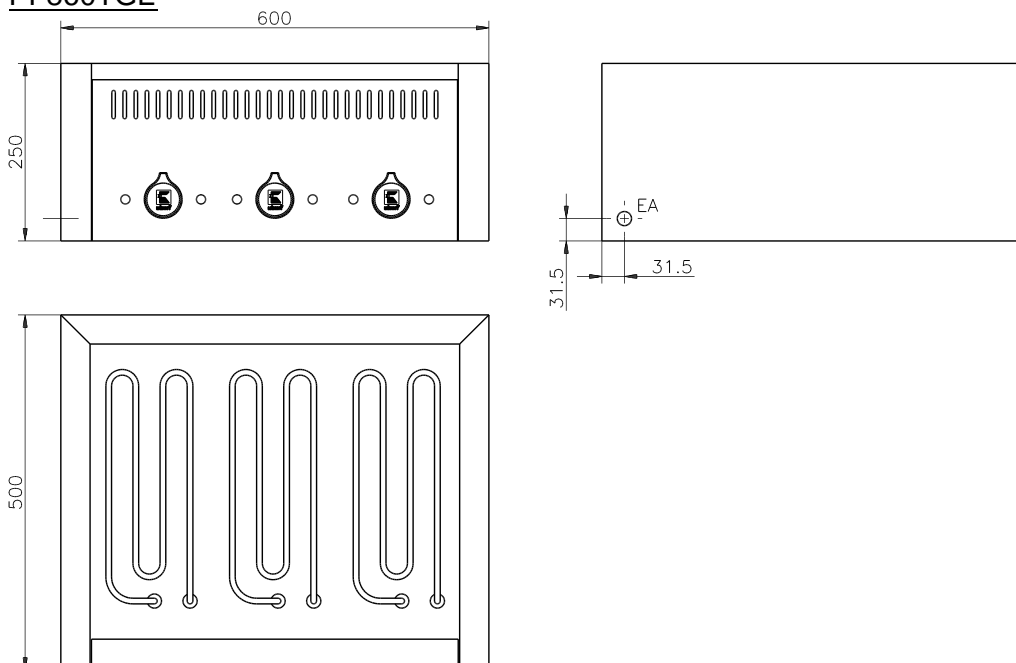



PF600SGES

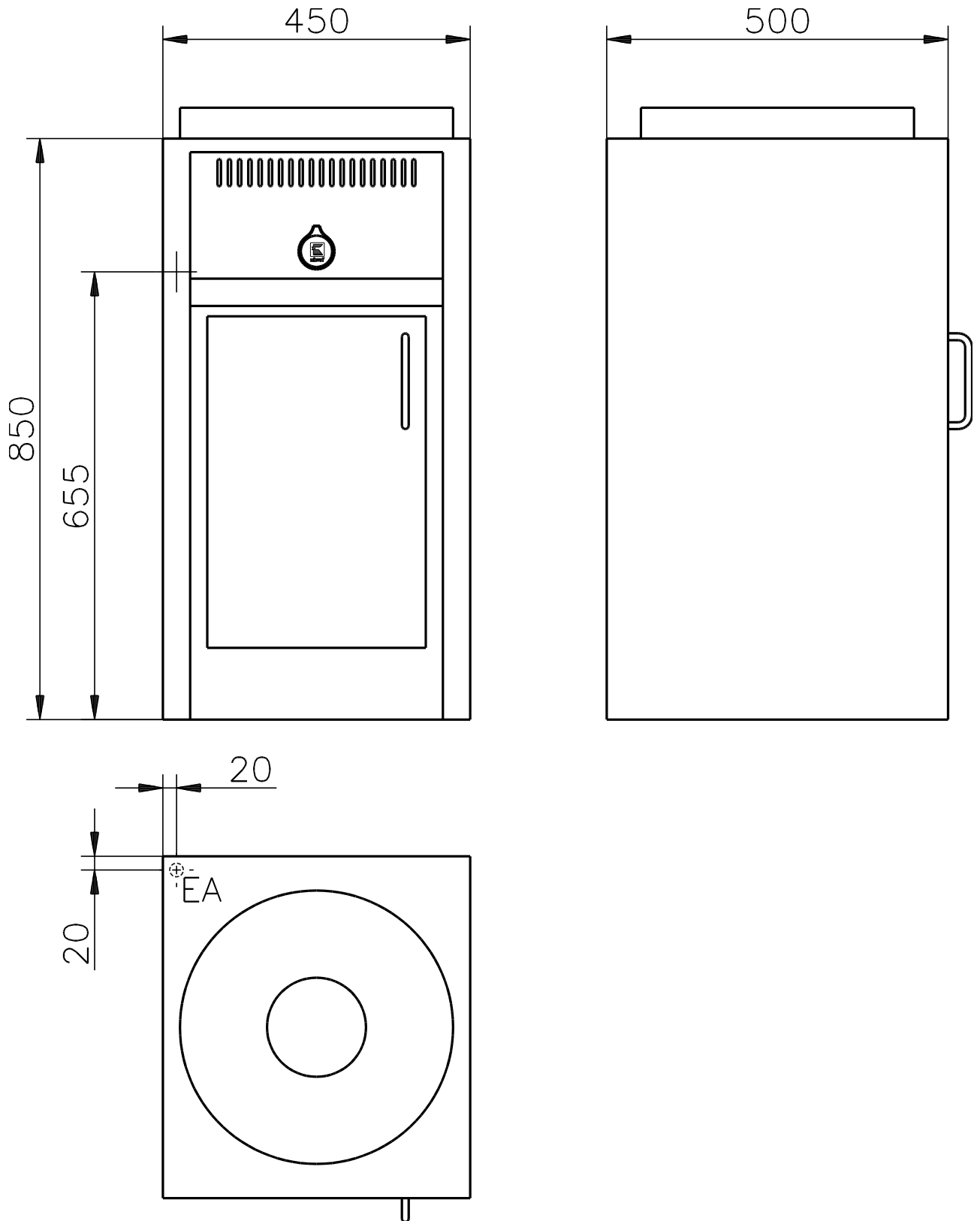

### 3.1.1 Weight

Type	weight (in kg)
PF600TGE	21
PF860TGE	21
PF600SGES	28
PF860SGES	35

### 3.1.2 Electrical details

Type	electrical connection [EA]	power]
PF600TGE	380-400V, 3Ph/N, 50/60Hz	5,2 kW
PF860TGE	380-400V, 3Ph/N, 50/60Hz	6,3 kW
PF600SGES	380-400V, 3Ph/N, 50/60Hz	5,2kW
PF860SGES	380-400V, 3Ph/N, 50/60Hz	6,3kW

### 3.1.3 Noise emission

Type	noise emission
all types	< 70 dB (A)

## 4 Installation and putting into operation

In general all Giant Pan Counter and Stand Units will be packed for safe transport after the final control in order to reach you properly. Nevertheless we ask you to have a look at the machine on arrival to detect any transport damages if there are any.



**Note!** Visible damages have to be reported immediately!

### 4.1 Unwrapping

- Open the carton and take out the wrapping material carefully.
- Take care that the delivery is complete (see attached freight papers).

### 4.2 Installation

Place the Unit in the desired location. Make sure, that it is good visible for your customer to ensure good food presentation and successful sales.



Take care of the following points:

- The Unit has to be placed on a horizontal level. Use a spirit level if necessary.
- There has to be enough free space to load, unload, clean and maintain the unit.
- The machine has to be placed so that the complete area around it can be cleaned easily.

### 4.3 Electrical connection

#### 4.3.1 Stand Units

**Note!** In general, only service technicians of the company: UBERT GASTRO-TECHNIK GMBH or service technicians of your responsible service partner are allowed to perform el. connection and other service! All national and local rules and regulations concerning electricity, fire protection and the like have to be considered. During any servicing, take care that the unit is disconnected from the mains! Not paying attention may result in injury!



Please learn the electrical and technical data of your unit from the nameplate.

- Check whether your local electrical power supply is in accordance with the values on the nameplate.
- The power supply needs to be manufactured from heat resistant, flexible cable. It is to be routed to prevent any contact to hot parts.
- The unit is to be connected to the power supply either by means of an appropriate plug or if connected permanently, a switch (interrupting all poles) is to be provided. In case of an emergency the power supply must be interruptable immediately.
- For further information please see the wiring diagram (below).

#### **Note!**

After finishing any installation work, maintenance or repair check whether the ground wires are connected properly to the casing.



### 4.3.2 Counter Unit

**Note!** Note that also after installation and electrical connection the plug must be accessible. If this is not possible due to structural reasons, or if the unit is connected permanently, the power supply needs to have an interlock switch.



**Note!** During any servicing, take care that the unit is disconnected from the mains! Not paying attention may result in injury!



Please learn the electrical and technical data of your unit from the nameplate.

- The unit is ready for plug-in.
- For power supply a CEE-socket is necessary.
- Make sure the supply cable is protected separately with 3 x 16 Amps.

**Note!**

After finishing any installationwork, maintenance or repair check whether the ground wires are connected properly to the casing.



### 4.4 Preparation of Using / Starting up

Before you can use the Pan Unit you have to clean it carefully with a grease solvent. Afterwards you have to dry all surfaces.

**Note!** Do not use flammable cleaners. Do not use high-pressure-, water pressure- or steam jet- cleaning machines. You will have further information about this in the section "cleaning and upkeeping".



After cleaning the Unit properly the smell will be minimal when using it the first time.

## 5 Operation

Following you will find explanation and location of all components and their function for the use of the Giant Pan Counter and Stand Units.

### 5.1 Operation elements

On the front panel are the operation elements. When the safety references are observed the unit can be operated without any difficulties.

**Attention!** The unit is not to be used without a pan.



#### 5.1.1 Operation PF600TGE / PF600SGES

With this unit the temperature is set by a 4 step switch. You can choose by switch positions 1,2,3 between 1/3, 2/3 and full power.

We recommend to use the position 3 only for fast heating up the pan.

The yellow control lamp above the knob shows that the unit is switched on.

To switch the unit off turn the knob into position 0. The yellow control lamp goes out.

#### 5.1.2 Operation PF860TGE / PF860SGES

This unit is controlled by energy controls. The unit is infinitely adjustable from 1 to 8. You find the marks on the control knob. Within the adjustment steps 1 - 7 the energy control works with a bi-metal-controlled interval switch. This guarantees a constant temperature.

The yellow control lamp shows the heating phases. The green control lamp shows that the unit is ready for operating.

When the control knob is adjusted to position 8 the energy control works constantly with full power.

There is no control in this position, which means the unit is always fully heating. We recommend to use the position 8 only for fast heating up the unit.

To switch the unit off turn the control knob into position 0.

## 6 Maintenance

Following we will show you some advices concerning maintenance, care, trouble shooting and service for your Giant Pan Counter and Stand Units.

### 6.1 Cleaning and care

#### 6.1.1 Safety advices

- Before you start to clean and care switch off the appliance and disconnect it from the mains.
- Do not use inflammable detergents, sharp-edged or metallic things for cleaning the unit! Never use high-pressure-, water pressure- or steam jet- cleaning machines!
- Wear acidproof gloves while cleaning the parts to prevent skin irritations.



#### 6.1.2 General Recommendations

- The unit has to be cleaned daily.
- Only use cleaners that are appropriate for food (neutral or alkaline detergents), even if there are plain and persistent residues.
- After cleaning with special cleaners you have to wash all parts with clear water and dry them afterwards so that there are no residues of the cleaner on these parts.
- It is absolutely necessary to watch out for some fundamental things to keep this longliving high-grade-steel-machine working:
  - always keep the high-grade-steel surface clean.
  - watch out that there is always enough fresh air on the surface
  - never contact the surface with rusty material
- never use bleaching or chlorine cleaners.
- Take brushes with plastic or natural bristles for cleaning.



#### 6.1.3 Detergents

To make the cleaning fast and easy we have integrated some cleaners in our program:

- Grill- and oven-cleaner:  
To dispose persistend, dried-up dirt on metal surfaces.
- Intensiv-cleaner:  
Detergent for metal- and plastic-surfaces.
- Glass-cleaner:  
Removes fat from glass-surfaces.
- Stainless-steel-cleaner  
You have to spray this from a distance of app. 25 cm on the surface and wipe it off with a dry cleaning rag. If you want to clean only small parts you have to spray it directly on the cleaning rag and wipe it off this way. With this method it is possible to clean the Cold Display Cabinet easily and without stripes.



## 6.2 Trouble shooting

If your Pan Unit does not work satisfactorily we would like to give a first help with the following check list. Only after checking these points you should contact:

a) your responsible service partner

or

b) directly the company: UBERT GASTROTECHNIK GMBH  
Werk II Gewerbegebiet Nord  
Vennekenweg 17  
46348 Raesfeld  
Tel.:02865 / 602-226  
Service-Tel.:0172 / 2 82 86 31  
Fax:02865 / 602-102 (or -103)

Only these two companies are allowed to carry out service work and replacement of defect parts. If you do not observe this note or in case of manipulation of a third party any claims for guarantee will become invalid!



### Checklist for your Giant Pan Counter and Stand Units:

1. Is the unit wired properly and connected to the mains?
2. Does the wall socket provide the required current / voltage (see the nameplate for details)?
3. Does the fuse protection work properly?

### 6.3 Wiring Diagrams

#### 6.3.1 PF600TGE / PF600SGES

380-400V, 3Ph/N, 50/60Hz

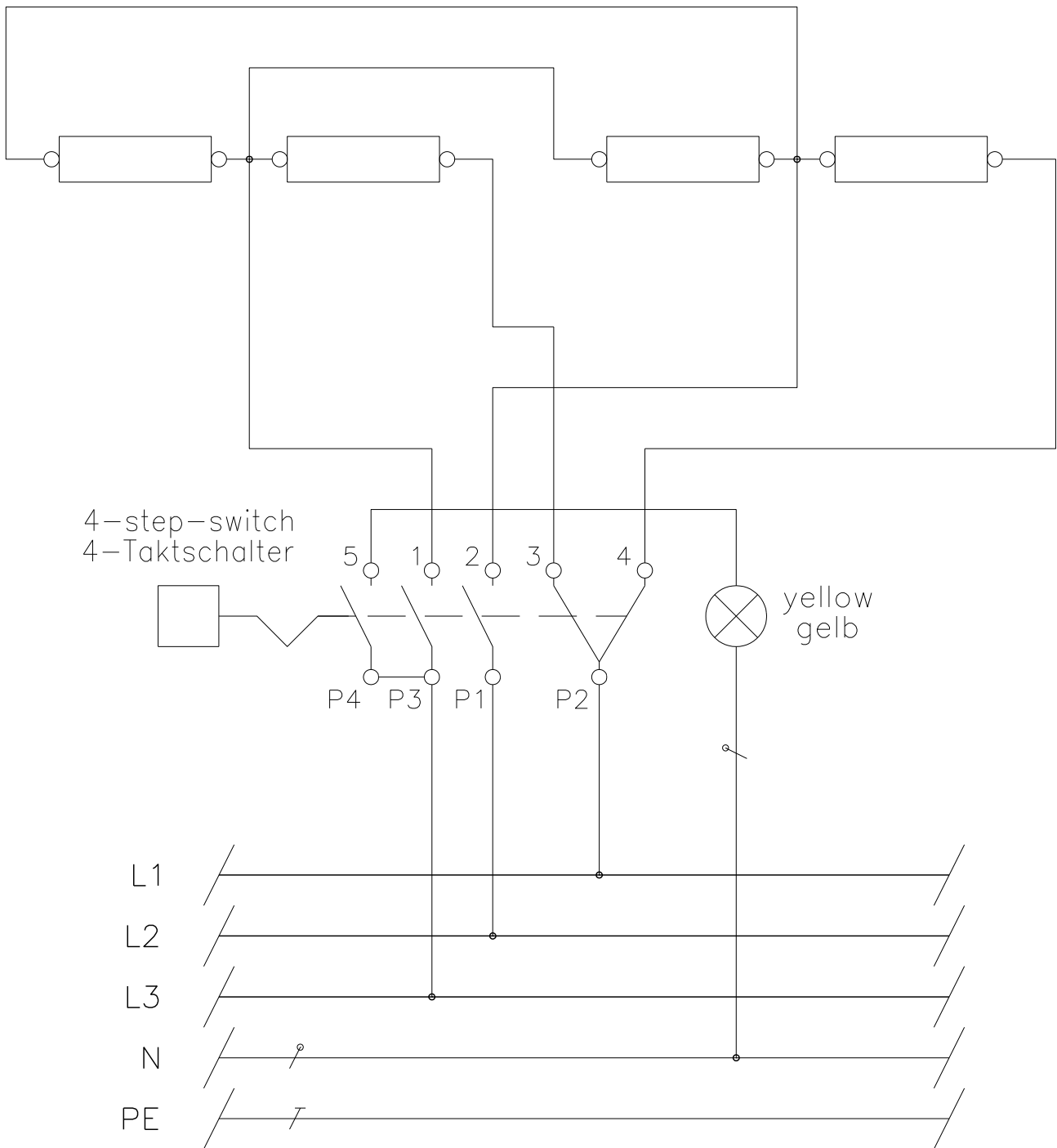



6.3.2 PF860TGE / PF860SGES

380-400V, 3Ph/N, 50/60Hz

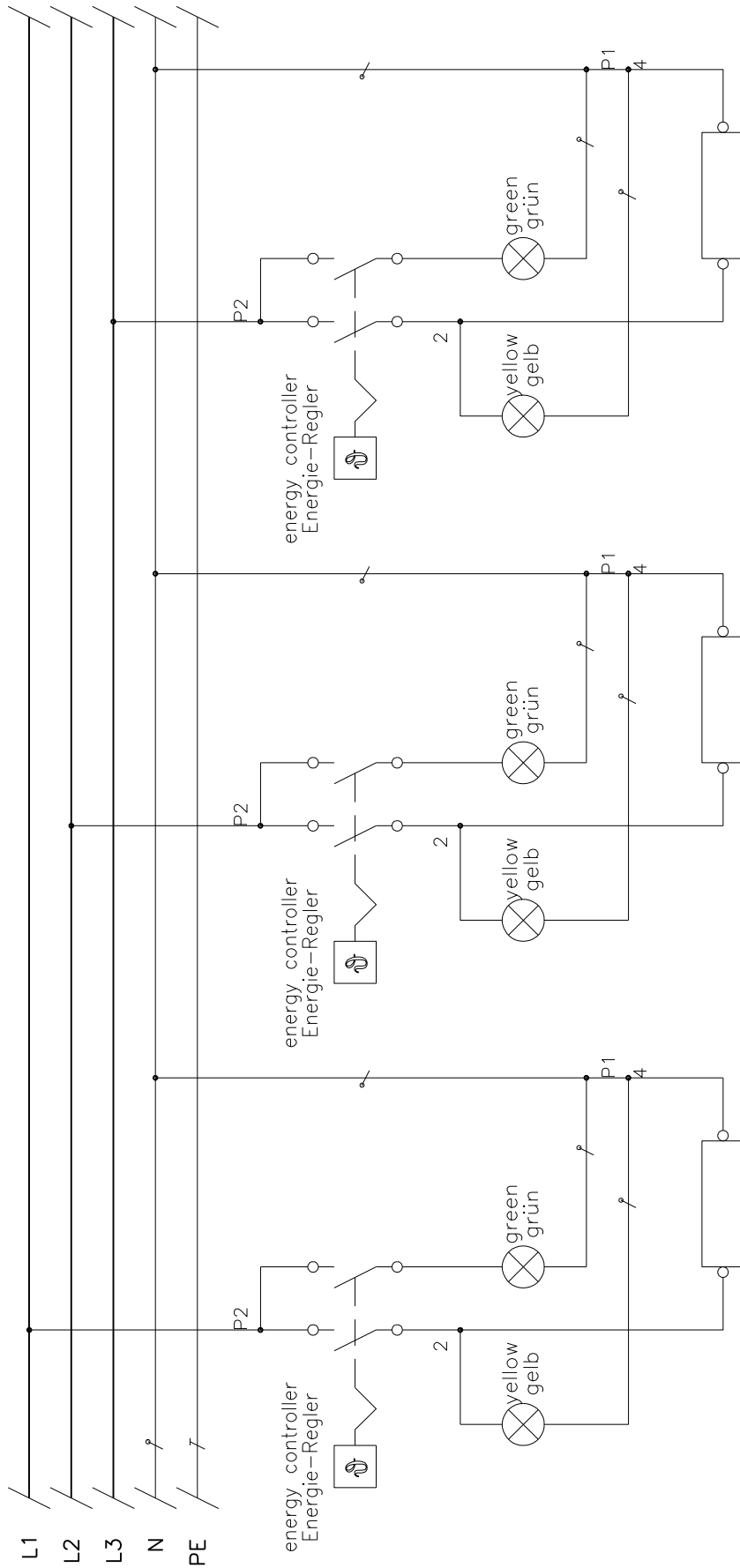









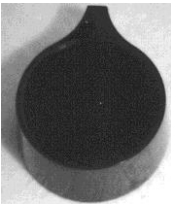

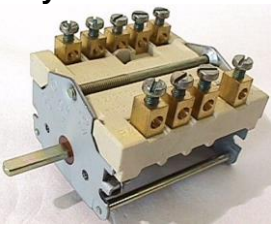
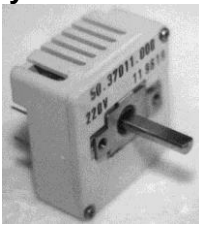

### 6.4 Spare Parts

Defect parts are to be replaced only by original spare parts of UBERT GASTROTECHNIK GMBH; the replacement is to be carried out only by their service personal or by your authorized Service companies. If you do not observe this note or in case of manipulation of a third party any claims for guarantee will become invalid! Also all certifications (CE, UL, NSF and the like) become invalid!

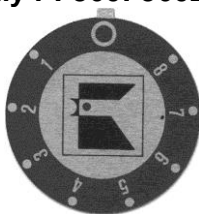

#### 6.4.1 Spare Parts List

<p>knob <b>361310</b></p> 		<p>lamp, yellow <b>340732</b></p> 	<p>plug CEE 16A <b>only Counter Unit: 341315</b></p> 
<p>strain relief <b>only Counter Unit: 338104</b></p> 		<p>strain relief counter nut <b>only Counter Unit: 338108</b></p> 	<p>reducer ring strain relief <b>only Counter Unit: 338116</b></p> 
<p>4-step-switch <b>only PF600: 341134</b></p> 		<p>energy controller <b>only PF860: 341141</b></p> 	<p>hot plate <b>only PF600: 343205</b></p> 
<p>heating element <b>only PF860: 343102</b></p> 		<p>scale 1-3 <b>only PF600: 360218</b></p> 	<p>scale 1-8 <b>only PF860: 360204</b></p> 
<p>lamp, green <b>only PF860: 340733</b></p> 			

## 6.5 PF ET Declaration Of Conformity

UBERT GASTROTECHNIK GMBH  
Gewerbegebiet Ost + Nord  
D-46348 Raesfeld

Telefon: +49 (0) 28 65 / 602-0  
Fax: +49 (0) 28 65 / 602-102  
Internet: www.ubert.com  
e-mail: info@ubert.com



# CE KONFORMITÄTSERKLÄRUNG DECLARATION OF CONFORMITY CERTIFICAT DE CONFORMITÉ

Hereby we declare that the unit noted below, on the basis of its concept, design and version, meets all basic health and safety requirements of the applicable EC-directive. This declaration is no longer effective in case this machine has been modified without our approval.

**Product designation:** Giant Pan Counter Unit

**Model:** PF ET

**EC-directives followed:** EC-directive for machines **2006/42/EG**  
EC-directive for low voltage **2006/95/EG**  
Electromagnetic compatibility **2004/108/EG**  
EC-directive for ecodesign requirements for energy-related products **2009/25/EG**

**Harmonized European Standards:** EN 55014 Electromagnetic compatibility – Requirements for household appliances,  
EN 61000-6-2 Electromagnetic compatibility – Generic immunity standard  
EN 60335-1 Safety of household and similar electrical appliances  
EN 60335-2 Safety of household and similar electrical appliances

**Applied national standards and technical specifications:** BGR111 directions for safety and health protection regarding kitchen work  
VDE 0700 Safety of household and similar electrical appliances

This declaration does not include any assurance of characteristics.

The safety references enclosed with the product documentation have to be followed.

By internal actions it is guaranteed, that all serial units meet the demands of the corresponding EC directive and the applied standards.

The signers are entitled to compose the technical documents.

Raesfeld, 01.01.10  
UBERT GASTROTECHNIK GMBH  
*C. Stephan*  
Christoph Stephan  
Vice President, R&D / Engineering

Raesfeld, 01.01.10  
UBERT GASTROTECHNIK GMBH  
*M. Peters*  
Michael Peters  
Service - Manager

Manufactured by: UBERT GASTROTECHNIK GMBH  
Gewerbegebiet Ost + Nord  
D-46348 Raesfeld

## 6.6 PF ES Declaration Of Conformity

UBERT GASTROTECHNIK GMBH  
Gewerbegebiet Ost + Nord  
D-46348 Raesfeld

Telefon: +49 (0) 28 65 / 602-0  
Fax: +49 (0) 28 65 / 602-102  
Internet: www.ubert.com  
e-mail: info@ubert.com



# CE KONFORMITÄTSERKLÄRUNG DECLARATION OF CONFORMITY CERTIFICAT DE CONFORMITÉ

Hereby we declare that the unit noted below, on the basis of its concept, design and version, meets all basic health and safety requirements of the applicable EC-directive. This declaration is no longer effective in case this machine has been modified without our approval.

**Product designation:** Giant Pan Stand Unit

**Model:** PF ES

**EC-directives followed:** EC-directive for machines **2006/42/EG**  
EC-directive for low voltage **2006/95/EG**  
Electromagnetic compatibility **2004/108/EG**  
EC-directive for ecodesign requirements for energy-related products **2009/25/EG**

**Harmonized European Standards:** EN 55014 Electromagnetic compatibility – Requirements for household appliances.  
EN 61000-6-2 Electromagnetic compatibility – Generic immunity standard  
EN 60335-1 Safety of household and similar electrical appliances  
EN 60335-2 Safety of household and similar electrical appliances

**Applied national standards and technical specifications:** BGR111 directions for safety and health protection regarding kitchen work  
VDE 0700 Safety of household and similar electrical appliances

This declaration does not include any assurance of characteristics.

The safety references enclosed with the product documentation have to be followed.

By internal actions it is guaranteed, that all serial units meet the demands of the corresponding EC directive and the applied standards.

The signers are entitled to compose the technical documents.

Raesfeld, 01.01.10  
UBERT GASTROTECHNIK GMBH

Christoph Stephan  
Vice President, R&D / Engineering

Raesfeld, 01.01.10  
UBERT GASTROTECHNIK GMBH

Michael Peters  
Service - Manager

Manufactured by: UBERT GASTROTECHNIK GMBH  
Gewerbegebiet Ost + Nord  
D-46348 Raesfeld