

User Manual

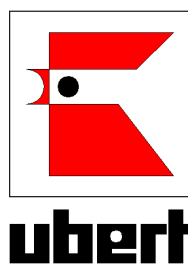

**DELI COLD CABINET
DKT-Series**



1 Contents

1	Contents	3
2	Important References	4
2.1	Fundamental Safety Notes	4
2.2	Warranty and Liabilities	5
2.3	Symbols and Notes	5
2.4	Copyright	5
2.5	Special safety references	6
3	Introduction	8
3.1	Introduction	8
3.2	Special features	8
	• Technical details	9
4	Installation and putting into operation	12
4.1	Unwrapping	12
4.2	Installation	12
4.3	Electrical connection	12
4.4	Preparation of Using / Starting up	13
5	Operation	14
5.1	Operation elements	14
5.2	Operating the Digital Control	15
6	Maintenance	16
6.1	Cleaning and care	16
6.2	Trouble shooting	18
6.3	Wiring Diagrams	19
6.4	Spare Parts	20
6.5	Declaration of Conformity	25

2 Important References

2.1 Fundamental Safety Notes

2.1.1 Consider notes in the operating manual

Precondition for the safe and trouble free use of this unit is the knowledge of the fundamental safety notes and safety regulations.

The operating instruction contains the most important references to operate the unit safely.

This operating instruction, particularly the safety references, is to be considered by all persons, who work on the unit.

Furthermore the rules and regulations to avoid accidents are to be considered.

2.1.2 Obligation of the operator

The Operator is obliged to only let persons work with the unit who:

- Are familiar with the fundamental regulations of work safety and accident avoiding and who have been instructed how to operate the unit.
- Read and understood the chapter about safety and warning notes and have confirmed this with their signature.

The safe conscious operation of the personnel has to be examined regularly.

2.1.3 Obligation of the personnel

All individuals who are authorized to work with the unit are obliged to:

- pay attention to the fundamental regulations of work safety and accident avoiding,
- Read the chapter on work safety and warning notes in this manual and to confirm through their signature that they have understood these, before actually operating the unit.

2.1.4 Possible risks

Deli Cold Displays are built state of the art and in acknowledgement of all safety related rules. Nevertheless is it possible that danger for body and life of the user and/or third and/or impairments at the unit or at other real values merge. The unit is to be used only:

- For the due use.
- In safety related flawless condition.

Disturbances which can hurt the safety are to be eliminated immediately.

2.1.5 Due use

The Deli Cold Displays are built exclusively for the cooling of food only. Any other use of the unit are only allowed after consulting UBERT GASTROTECHNIK GMBH. Damages which result out of wrong use UBERT GASTROTECHNIK GMBH cannot be held responsible. Part of the due use is also:

- the consideration of all references of the operating manual and
- the observance of necessary maintenance and service.

2.2 Warranty and Liabilities

Fundamentally our "General terms of sale and delivery" count. These are known to the operator at the latest since signing of the contract. Claims to warranty and liability at persons- and property damages are impossible, if they are to be led back to one or several of the following causes:

- Non due use of the unit.
- Improper assembling, starting up, operating and servicing of the unit.
- Operating the unit with defective safety devices or safety devices which have not been installed properly and are in no working condition.
- Defiance of the references in the operating manual concerning transportation storage, installation, start-up, operation, maintenance and assembling of the unit.
- Unauthorized mechanical or electrical changes of the unit.
- Insufficient maintenance of wear and tear parts.
- Unauthorized repair.
- Force of nature and act of god.

2.3 Symbols and Notes

In the operating manual the following symbols and signs are used:



This symbol means a possibly or directly threatening danger for the life and the health of persons and/or a possibly dangerous situation.
Ignoring of these references may result in consequences for your health and/or can lead to property damages!



This symbol points to important references for the proper use of the unit.
Not paying attention to these references can lead to disturbances at the unit or in the environment!



This symbol points to operation tips and especially useful information.
Help to use all functions at your unit optimally.

2.4 Copyright

The copyright on this operating manual remains at the company UBERT GASTROTECHNIK GMBH. This operating manual is intended only for the operator and his personal. It contains instructions and references which neither completely nor partially:

- be duplicated
- be circulated or
- be otherwise made available to third parties.

Offences may violate applicable laws.



2.5 Special safety references

2.5.1 Safety devices

- Before operating the unit all protective devices as well as all removable parts must be installed correctly and be fully workable.
- Protective devices may only be removed:
 - after stand still and
 - prevention of unintentional restart.
 - If partial components are delivered, an authorized staff member or service technician has to execute assembly according to installation guidelines.

2.5.2 Informal safety steps

- The operating manual is to be kept constantly accessible in the operating area.
- In addition to the operating manual all generally acknowledged and all local regulations for accident avoiding and environmental protection have to be applied with.
- All safety- danger labels at the unit are to be kept in readable condition.

2.5.3 Education of the personnel

- Only trained and instructed personal may work at the unit.
- The responsibilities of the personal are to be determined clearly for installing, start-up, operation, assembling, and servicing of the unit.
- During instruction the personal may only work at the unit under supervision of an experienced person.

2.5.4 Unit-control

- Only instructed personal is allowed to operate the controls.

2.5.5 Safety during regular operation

- The unit is only to operate if all protective devices are fully workable.
- At least once per shift the unit is to be examined with regard to visible damages and functional ability of the safety devices.

2.5.6 Dangers caused by electric energy

- Any work on the electrical supply is to be executed only by a specialist.
- Likewise the electrical connection of this unit to the power supply must be executed by an electro-specialist; the connection must follow the rules of the local determinations.
- The electric installation is to be examined regularly. Loose connections and brased cables are to be eliminated immediately.
- If works at any life-parts are necessary, a second person who switches off the main switch if necessary is to consult.

2.5.7 Special danger-spots

- Remove the cover plate only if unit is switched off!
- Do not touch the refrigerator when unit is switched on!
- Do not touch the evaporator! Danger of injuring oneself!

2.5.8 Service and maintenance, troubleshooting

- Prescribed adjustment, service and inspection work is to be accomplished timely by the manager or if necessary by an authorized service technician.
- The operating personal is to be informed before the beginning of the maintenance and service work.
- The unit is to be disconnected from the mains before maintaining, inspecting and repairing is performed; the main switch is to be guarded against unintended reclosing.
- Check all screw connections for tight fitting.
- After finishing maintenance check all safety devices for proper functionality.

2.5.9 Structural changes to the unit

- Do not perform any changes, extensions or conversions to the unit without the manufacturer's permission, especially welding work at supporting parts.
- For all conversions a written permission of the company UBERT GASTROTECHNIK GMBH is necessary.
- Change all parts of the unit, which are in improper condition.
- Use only original spare parts.

2.5.10 Cleaning of the unit and disposal of the waste

Used substances and materials are to be handled and disposed appropriately, especially lubricants. Detergents have to follow the rules of food-hygiene.

3 Introduction

3.1 Introduction

All Deli Cold Cabinets are synonymous in construction and therefore you will have the possibility of an optimum integration in a complete display conception. An adjustable temperature control enables you to set the desired cooling temperature. We guarantee a constant temperature even in case of opened doors. The temperature rises only after some minutes. The Deli Cold Cabinets show a high cooling performance. Within the Deli Cold Cabinets, the cooling convection provides a stable temperature. The set temperatures are reached within one hour, the degree of condensation is low.

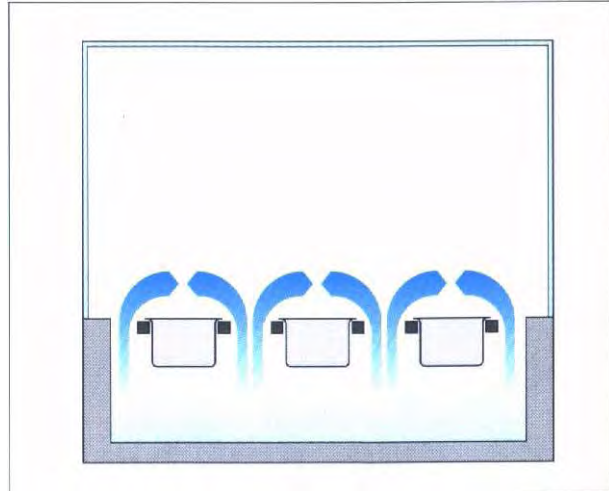

The maximum holding time depends on the kind of product and on the products starting temperature. It might be limited by national or local regulations. Never equip the cabinet with warm or hot products.



3.2 Special features

- Ergonomic, stylish design
- Maximum product visibility by curved front glass
- Decorative stand (optional with bag shelf and bumpers)
- Easy handling of the curved front glass by pressure lifts
- Optimized product-presentation by variable 100mm GN-pan equipment or decorative bowls
- Meeting the hygienic requirements in accordance with HACCP
- All models are available as self-service equipment for impulse buying

- **Technical details**
- **Dimensions [mm]**

DKT 31 and DKT31SS (without stand):

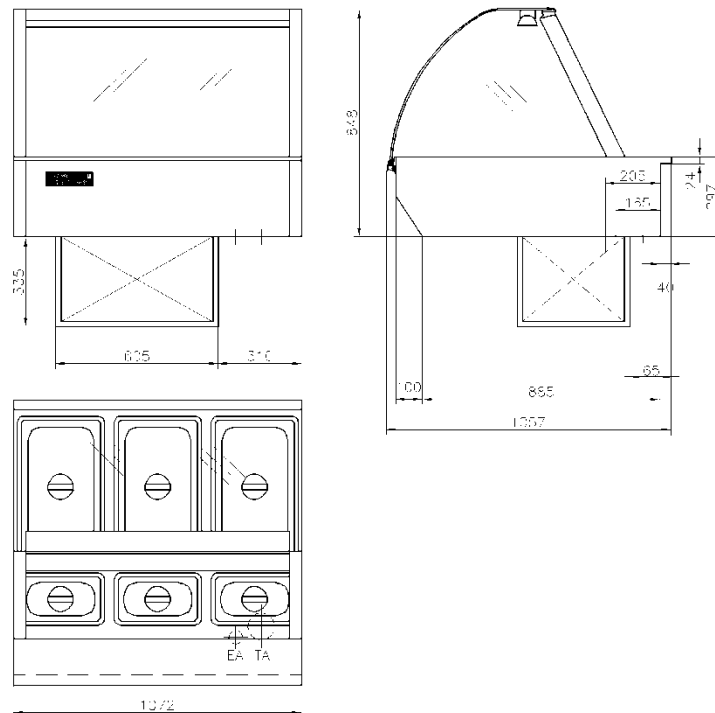

DKT 41 and DKT 41 SS (without stand):

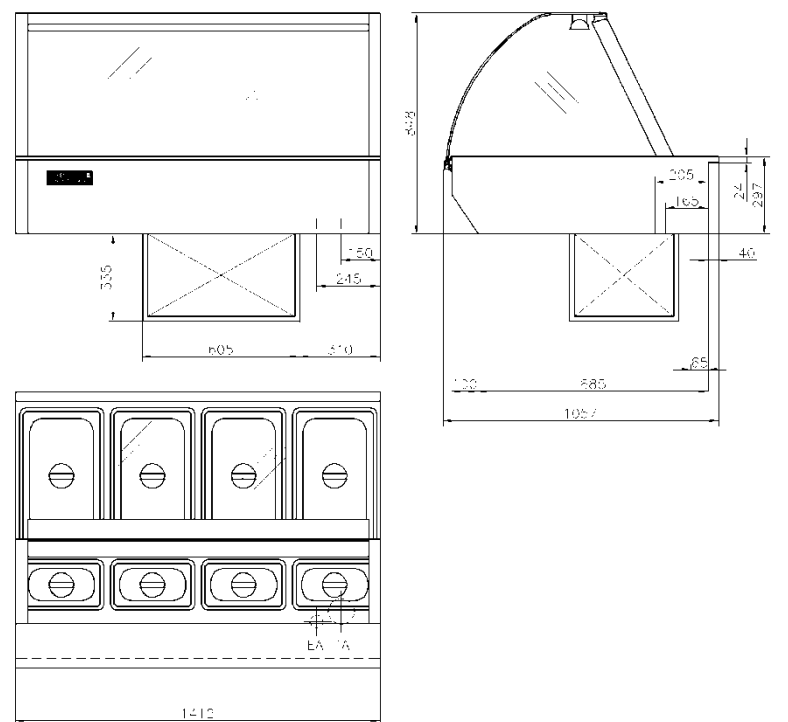

DKT 51 and DKT51SS (without stand):

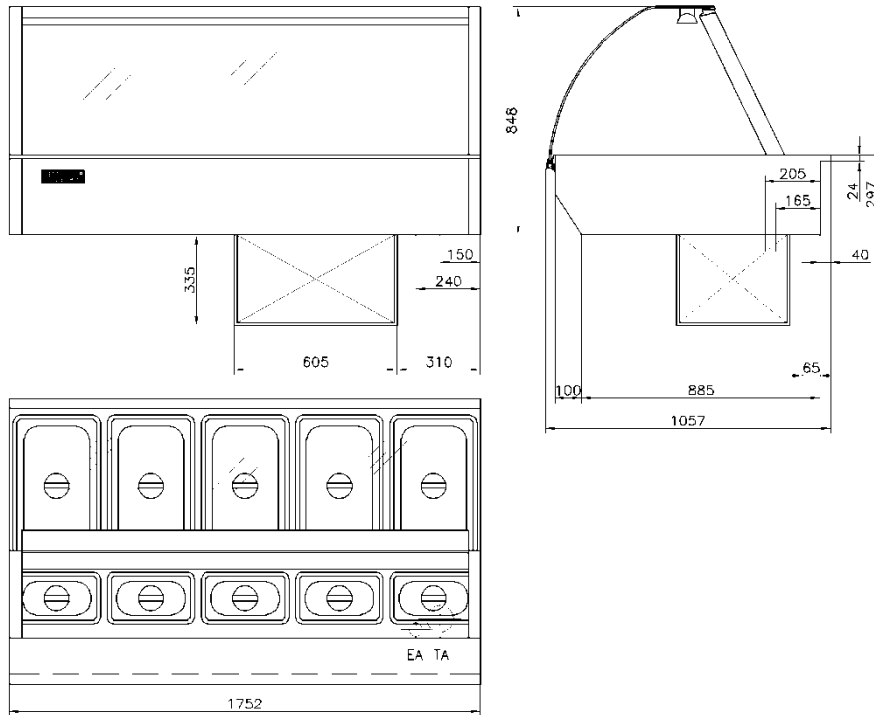

DKT 71 and DKT 71 SS (without stand):

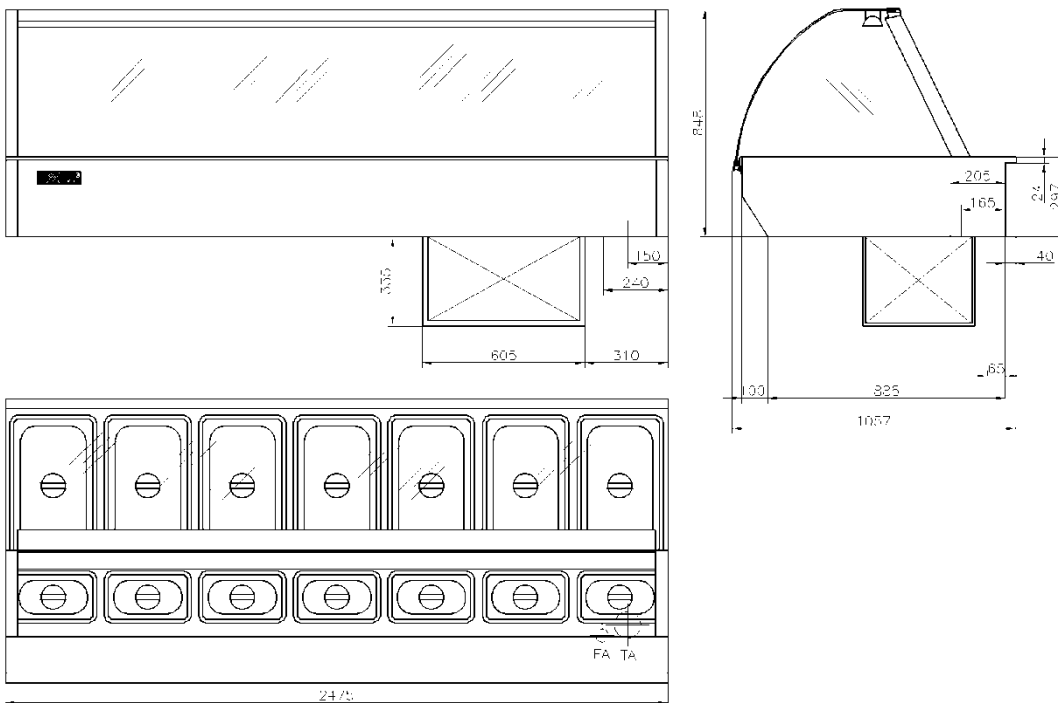

3.2.1 Weight

Type	weight [kg]	DKT
31	app. 153	
DKT 31SS	app. 153	
DKT 41	app. 181	
DKT 41SS	app. 181	
DKT 51	app. 209	
DKT 51SS	app. 209	
DKT 71	app. 265	
DKT 71SS	app. 265	

3.2.2 Electrical details

Type	electrical connection [EA]	power	drain [TA]	DKT
31	230V, 1/N, 50Hz	0.68kW	1 1/2"	
DKT 31SS	230V, 1/N, 50Hz	0.68kW	1 1/2"	
DKT 41	230V, 1/N, 50Hz	0.78kW	1 1/2"	
DKT 41SS	230V, 1/N, 50Hz	0.78kW	1 1/2"	
DKT 51	230V, 1/N, 50Hz	1.00kW	1 1/2"	
DKT 51SS	230V, 1/N, 50Hz	1.00kW	1 1/2"	
DKT 71	230V, 1/N, 50Hz	1.1kW	1 1/2"	
DKT 71SS	230V, 1/N, 50Hz	1.1kW	1 1/2"	

3.2.3 Noise emission

Type	noise emission
all types	< 70 dB (A)

3.2.4 Refrigerant

Refrigeration medium for all Cold Display Cabinets: R 134 A

4 Installation and putting into operation

In general all Deli Cold Displays will be packed for safe transport after the final control in order to reach you properly. Nevertheless we ask to look at the machine on arrival to detect any transport damages.



Note! Visible damages have to be reported immediately!

4.1 Unwrapping

- Open the carton and take out the wrapping material carefully.
- Take care that the delivery is complete (see attached freight papers).

4.2 Installation

Place the cabinet in the desired location. Make sure, that it is good visible for your customer to ensure good food presentation and successful sales.



Take care of the following points:

- Place the Cabinet dry.
- Take care that the Cabinet has to be placed in well ventilated rooms!
- Avoid placing the cabinet close to any heat-sources (heaters, radiators, sunbeams and the like).
- The cooling compartment (condenser and compressor) below the cabinet must be well ventilated after installation.
- The cabinet (with or without stand) has to be placed on a horizontal level; use a spirit level if necessary.
- Take care that both sides have at least 10 cm clear space to enable cleaning of the side glasses.
- If you have chosen permanent water drainage, provide a flexible tube-connection.
- There has to be enough free space to load, unload, clean and maintain the unit.
- The machine has to be placed so that the complete area around it can be cleaned easily.

4.3 Electrical connection

Note! In general, only service technicians of the company: UBERT GASTRO-TECHNIK GMBH or service technicians of your responsible service partner are allowed to perform el. connection and other service! All national and local rules and regulations concerning electricity, fire protection and the like have to be considered. During any servicing, take care that the unit is disconnected from the mains! Not paying attention may result in injury!



Please learn the electrical and technical data of your unit from the nameplate.

- Check whether your local electrical power supply is in accordance with the data on the name plate.
- Make sure the supply cable is protected as listed below:
(5- wire, min. cross-section 1,5□) separately with 16 Amps.
- The power supply needs to be manufactured from flexible cable. It is to be routed to prevent any contact to hot parts.
- The unit is to be connected to the power supply either by means of an appropriate plug or if connected permanently, a switch (interrupting all poles) is to be provided. In case of an emergency the power supply must be interrupted immediately.
- For further information please see the wiring diagram (below).

4.4 Preparation of Using / Starting up

Before you can use the Deli Cold Display you have to clean the unit and all removable parts (e. g. GN-basins) carefully with a grease solvent. Afterwards you have to dry all surfaces.

Note! Do not use flammable cleaners. Do not use high-pressure-, water pressure- or steam jet- cleaning machines. You will have further information about this in the section "cleaning and up keeping".



After cleaning the Cabinet properly the smell will be minimal when using it the first time.

5 Operation







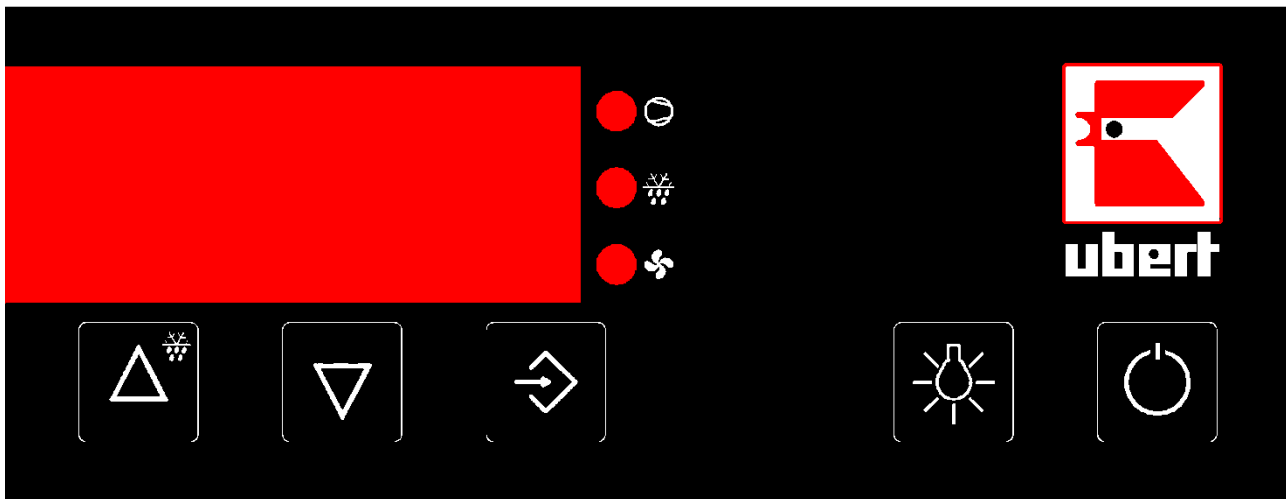







Following you will find explanation and location of all components and their function for the use of the cabinet.

5.1 Operation elements

Digital Control



5.2 Operating the Digital Control

<p>STANDBY button</p> 	<p>Switches the cabinet ON and OFF.</p>	
<p>LIGHT Button</p> 	<p>Switches the lights inside the cabinet ON and OFF.</p>	
<p>PPROGRAMMING button</p> 	<p>Keep pushed to change the set temperature using  and .</p>	
<p>UP button</p> 	<p>Push the UP button for min. 3 seconds to start a defrost cycle While  is pushed, use the UP button to increase the set temperature.</p>	
<p>DOWN Button</p> 	<p>While  is pushed, use the DOWN button to decrease the set temperature. Also used to quit alarms.</p>	
<p>COMPRESSOR Symbol</p> 	<p>Is illuminated whenever the actual temperature is above the set temperature and the compressor is running.</p>	
<p>DEFROST Symbol</p> 	<p>Is illuminated whenever the cabinet is running a defrost cycle</p>	
<p>FAN Symbol</p> 	<p>Is illuminated whenever the fans are running.</p>	
<p>DISPLAY</p> 	<p>The DISPLAY shows the actual temperature. While  is pushed, it shows the set temperature. While the Cabinet is switched off the display shows "OFF"</p>	
<p>Cutting Board:</p>	<p>Workspace to cut your products and do various other handling during loading, unloading, packing and the like.</p> <p>Note! Do not place hot items on the cutting board.</p>	

6 Maintenance

Following we will show you some advices concerning maintenance, care, trouble shooting and service for your Deli Cold Display.

6.1 Cleaning and care

6.1.1 Safety advices

- Before you start to clean and care switch off the appliance and disconnect it from the mains.
- Do not use inflammable detergents, sharp-edged or metallic items for cleaning the unit! Never use high-pressure-, water pressure- or steam jet- cleaning machines!
- Wear acid proof gloves while cleaning the parts to prevent skin irritations.



6.1.2 General Recommendations

- The unit has to be cleaned daily.
- Only use cleaners that are appropriate for food (neutral or alkaline detergents), even if there are plain and persistent residues.
- After cleaning with special cleaners you have to wash all parts with clear water and dry them afterwards so that there are no residues of the cleaner on these parts.
- It is absolutely necessary to watch out for some fundamental things to keep this long living high-grade-steel-machine working:
 - always keep the high-grade-steel surface clean.
 - watch out that there is always enough fresh air on the surface
 - never contact the surface with rusty material
- Never use bleaching or chlorine cleaners.
- Take brushes with plastic or natural bristles for cleaning.



6.1.3 Detergents

To make the cleaning fast and easy we have integrated some cleaners in our program:

- Intensive-cleaner:
Detergent for metal- and plastic-surfaces.
- Glass-cleaner:
Removes fat from glass-surfaces.
- Stainless steel-cleaner
You have to spray this from a distance of app. 25 cm on the surface and wipe it off with a dry cleaning rag. If you want to clean only small parts you have to spray it directly on the cleaning rag and wipe it off this way. With this method it is possible to clean the Deli Cold Display easily and without stripes.



6.1.4 Special cleaning hints

Please find below some special cleaning tips for this specific unit:



- Lamps:
To be cleaned only with soft paper or cloth and alcohol.
- Glass:
Lift the curved front glass to clean the inside. Due to the pressure lifts it is easy to lift the curved front glass on serve over units. However, the opened glass should be secured by hand. Remove dust and dirt from the glass surface with soft cloth to avoid scratches.
- Drawers, GN-Pans:
Easily removable without tools for separate cleaning (picture A).
- Evaporator&air-openings, :
All air openings as well as the evaporator need to be cleaned regularly to ensure convection and cooling performance of the unit and also to minimize prevention of dirt particles into the fan and lamina of the evaporator. Damages to the unit can be prevented that way. The evaporator is covered with an evaporator cover plate. After removing the GN-pans and the air guiding plates this unit can be lifted and needs to be secured during the cleaning process (We recommend to involve a second person for this process). The cleaning can be effected with a vacuum cleaner or a brush. Be careful to prevent injuries or damage of the unit. Please follow our instructions A-F (above).
- Condenser:
It is important to keep the condenser clean and free of any obstructions
 - Do not place anything directly in front of the condenser.
 - Clean the condenser regularly, at least every 3 month.
 - Use a vacuum cleaner or a brush to clean the condenser
 - Do not use metal brushes
 This is necessary to ensure proper functionality of the condenser and compressor.

Noncompliance invalidates any warranty claim!



6.1.5 Defrost Cycle

The Deli Cold Cabinet is equipped with a pre-set defrost cycle. The defrost cycle takes place every 4 hours. During the defrost cycle the compressor is switched off while the fans continue to run. The defrost cycle runs until a temperature of 5 °C is reached. The length of the defrost cycle is limited to 30 minutes. If you need to have these settings to be changed, please ask your authorized service technician for guidance.

6.2 Trouble shooting

If your Deli Cold Display does not work satisfactorily we would like to give a first help with the following checklist. Only after checking these points you should contact:

a) your responsible service partner

or

b) directly the company: UBERT GASTROTECHNIK GmbH
Werk II Gewerbegebiet Nord
Vennekenweg 17
46348 Raesfeld
Tel.:(49) 02865 / 602-226
Service-Tel.:0172 / 2 82 86 31
Fax:(49) 02865 / 602-102 (or -103)

Only these two companies are allowed to carry out service work and replacement of defect parts. If you do not observe this note or in case of manipulation of a third party any claims for guarantee will become invalid!



Checklist for your Deli Cold Display:

1. Is the unit wired properly and connected to the mains?
2. Does the wall socket provide the required current / voltage (see the nameplate for details)?
3. Does the fuse protection work properly?
4. Does the unit cool properly? Please check power supply and control!
5. Have you possibly stored hot or warm goods?
6. Is the ventilation of cooling machine sufficient?
7. Is the evaporator iced?
8. Have you correctly adjusted the thermostat?
9. Do all lamps work properly? Check lamps and connection!

6.2.1 Error messages

Message	Means	What to do
E0 flashing in the Display	Temperature probe is short circuited or broken	Call for service
EP in the Display	Parameters lost	Switch the unit OFF and ON again; if message reappears, call for service
Flashing Temperature in the Display	Temperature alarm	Quit alarm pushing the DOWN button; check temperature settings; call for service
Beeper sounds	Temperature alarm	Quit alarm pushing the DOWN button; check temperature settings; call for service

6.3 Wiring Diagrams

6.3.1 DKT 31 - 71 and DKT31SS – 71SS 240V / 50Hz / 1/N

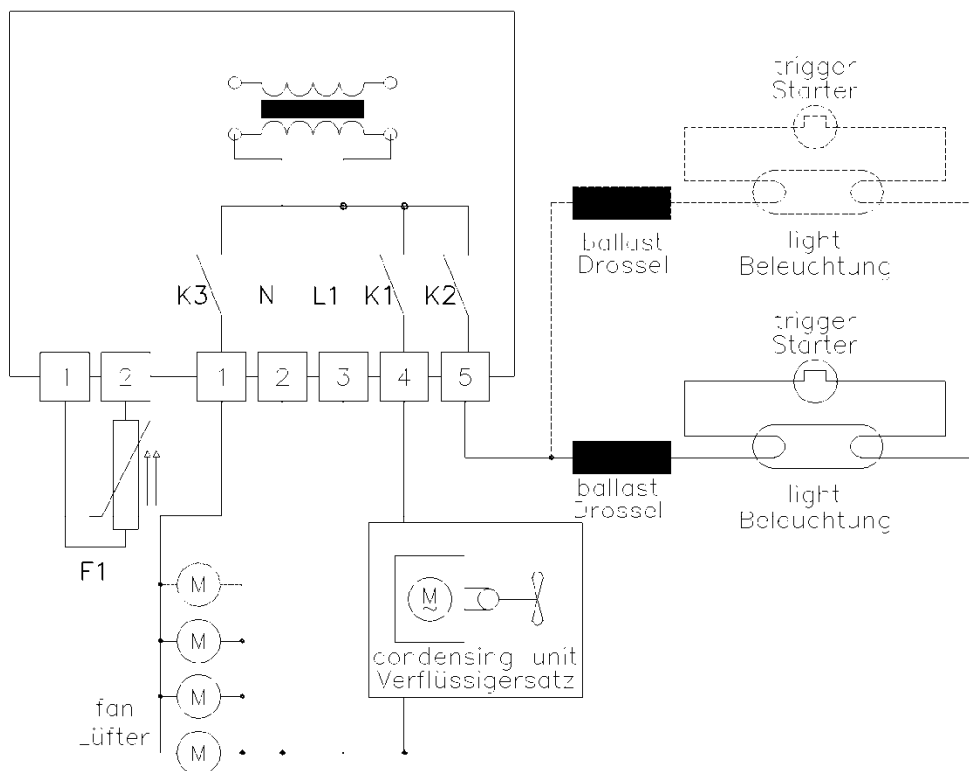

	lamp Lampe	fan Lüfter
DKT31	1x36W	3x
DKT41	1x36W	3x
DKT51	1x58W	4x
DKT71	2x36W	4x

6.4 Spare Parts

Defect parts are to be replaced only by original spare parts of UBERT GASTROTECHNIK GMBH; the replacement is to be carried out only by their service personal or by your authorized Service companies. If you do not observe this note or in case of manipulation of a third party any claims for guarantee will become invalid! Also all certifications (CE, UL, VDE, GS and the like) become invalid!



6.4.1 Explosion drawing DKT Series

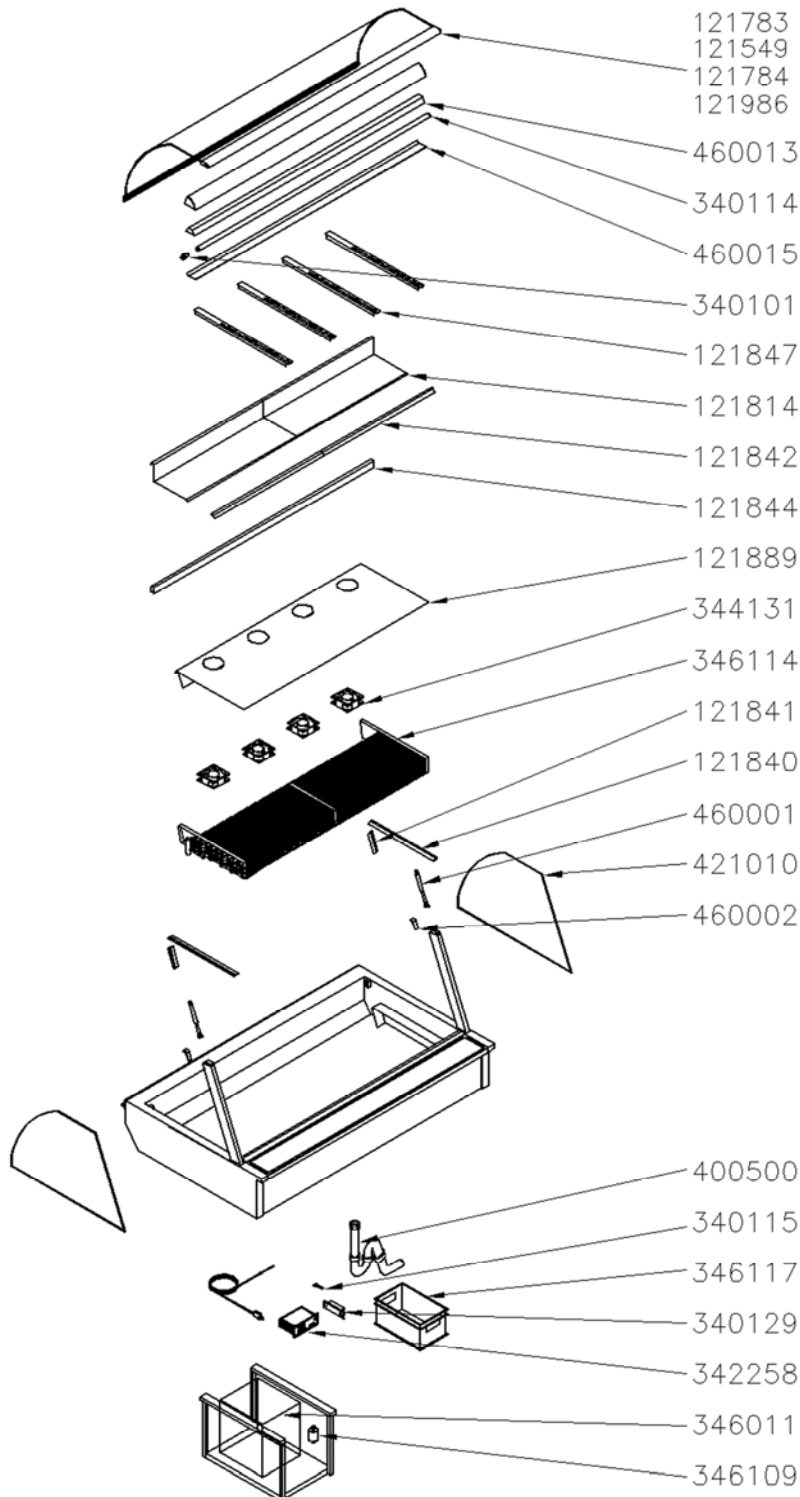

Spare parts**DKT31 and DKT31SS**

Amount	Part No.	Description	VT
1	121888	cover for evaporator	
2	121869	guide plate	
2	121866	intermediate web	
2	121870	guide rail	
1	400500	discharge with siphon	
1	346110	evaporator- DKT 31	
1	346010	refrigeration unit	
1	346109	filter drier	
4	121840	seal 485mm	
2	121841	seal 110mm	
3	344131	axial fan	
1	340108	lamp 36W	
1	340101o	lamp-starter 4-80W	
1	340115	screen capacitor	
1	340128	ballast 36W	
1	342258	Digital Control for KT, KTI, DKT	
1	342237o	Temperature probe PT100	
2	460101	Pressure lift 400N, Type 25	
2	460002	lighting screen holder	
1	460113	reflector	
1	460115	acrylic glass cover	
1	460011	Seal, Front for all Deli Series	X
1	121783	front glass assy DHT/DKT 31	
2	421010	side glass for DHT/DKT 31/41/51	
2	361508o	flange - Teflon, black	

6.4.2 Spare parts DKT41 and DKT41SS

Amount	Part No.	Description	VT
1	121889	cover for evaporator	
2	121869	guide plate	
2	121866	intermediate web	
2	121870	guide rail	
1	400500	discharge with siphon	
1	346110	evaporator- DKT 31	
1	346010	refrigeration unit	
1	346109	filter drier	
4	121840	seal 485mm	
2	121841	seal 110mm	
3	344131	axial fan	
1	340108	lamp 36W	
1	340101o	lamp-starter 4-80W	
1	340115	screen capacitor	
1	340128	ballast 36W	
1	342258	Digital Control for KT, KTI, DKT	
1	342237o	Temperature probe PT100	
2	460001	Pressure lift 700N, type 25, DHT/DKT51	
2	460002	lighting screen holder	
1	460113	reflector	
1	460115	acrylic glass cover	
1	460011	Seal, Front for all Deli Series	X
1	121549	front glass assy DHT/DKT41	
2	421010	side glass for DHT/DKT 31/41/51	
2	361508o	flange - Teflon, black	

6.4.3 Spare parts DKT51 and DKT51SS

Amount	Part No.	Description	VT
1	121809	air guide	
1	121844	guide rail	
1	121889	cover for evaporator	
2	121814	guide plate	
4	121847	intermediate rail for DKT 41/51 cpl.	
1	400500	discharge with siphon	
1	346114	evaporator DKT 51	
1	346011	refrigeration unit	
1	346109	filter drier	
2	121840	seal 485mm	
2	121841	seal 110mm	
2	121842	seal 825mm	
4	344131	axial fan	
1	340114o	fluorescent lamp 58W	
1	340101o	lamp-starter 4-80W	
1	340115	screen capacitor	
1	340129	ballast - 58 W	
1	342258	Digital Control for KT, KTI, DKT	
1	342237o	Temperature probe PT100	
2	460001	Pressure lift 700N, type 25, DHT/DKT51	
2	460002	lighting screen holder	
1	460013	reflector	
1	460015	acrylic glass cover	
1	460011	Seal, Front for all Deli Series	X
1	121784	front glass assy DHT/DKT 51	
2	421010	side glass for DHT/DKT 31/41/51	
2	361508o	flange - Teflon, black	

6.4.4 Spare parts DKT71 and DKT71SS

Amount	Part No.	Description	VT
1	121809	air guide	
1	121844	guide rail	
1	121889	cover for evaporator	
2	121814	guide plate	
4	121875	intermediate rail for DKT 31 cpl.	
1	121815	intermediate web	
1	400500	discharge with siphon	
1	346114	evaporator DKT 51	
1	346011	refrigeration unit	
1	346109	filter drier	
2	121840	seal 485mm	
2	121841	seal 110mm	
2	121842	seal 825mm	
4	344131	axial fan	
2	340108	lamp 36W	
2	340101o	lamp-starter 4-80W	
2	340115	screen capacitor	
1	342258	Digital Control for KT, KTI, DKT	
1	342237o	Temperature probe PT100	
8	460207	Pressure lift 400N	
2	460113	reflector	
2,47	460408	acrylic glass cover	
2,47	460011	Seal, Front for all Deli Series	X
1	121986	front glass curved DHT/DKT 71, assembly	X
2	421107	side glass for DHTG31/41/51/71	X
2	361508o	flange - Teflon, black	

6.5 Declaration of Conformity

UBERT GASTROTECHNIK GMBH
Gewerbegebiet Ost + Nord
D-46348 Raesfeld

Telefon: + 49 (0) 28 65 / 602-0
Fax: + 49 (0) 28 65 / 602-102
Internet: www.ubert.com
e-mail: info@ubert.com



CE KONFORMITÄTSERKLÄRUNG DECLARATION OF CONFORMITY CERTIFICAT DE CONFORMITÉ

Hereby we declare that the unit noted below, on the basis of its concept, design and version, meets all basic health and safety requirements of the applicable EC-directive. This declaration is no longer effective in case this machine has been modified without our approval.

Product designation: Cold Deli Display Cabinet

Model: DKT31 / DKT31SS

DKT41 / DKT41SS

DKT51 / DKT51SS

DKT71 / DKT71SS

EC-directives followed: EC-directive for machines 2006/42/EG

EC-directive for low voltage 2006/95/EG

Electromagnetic compatibility 2004/108/EG

Harmonized European Standards: EN 55014 Electromagnetic compatibility – Requirements for household appliances

EN 61000-6-2 Electromagnetic compatibility – Generic immunity standard

EN 60335-1 Safety of household and similar electrical appliances

EN 60335-2 Safety of household and similar electrical appliances

Applied national standards and technical specifications: BGR111 directions for safety and health protection regarding kitchen work

VDE 0700 Safety of household and similar electrical appliances

This declaration does not include any assurance of characteristics.

The safety references enclosed with the product documentation have to be followed.

By internal actions it is guaranteed, that all serial units meet the demands of the corresponding EC directive and the applied standards.

The signers are entitled to compose the technical documents.

Raesfeld, 01.01.10
UBERT GASTROTECHNIK GMBH

Christoph Stephan
Vice President, R&D / Engineering

Raesfeld, 01.01.10
UBERT GASTROTECHNIK GMBH

Michael Peters
Service - Manager

Manufactured by: UBERT GASTROTECHNIK GMBH
Gewerbegebiet Ost + Nord
D-46348 Raesfeld