

User Manual

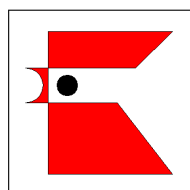

DELI HOT CABINET
DHT-Series



ubert®

1 Contents

1	Contents	3
2	Important References	4
2.1	Fundamental Safety Notes.....	4
2.2	Warranty and Liabilities.....	5
2.3	Symbols and Notes	5
2.4	Copyright.....	5
2.5	Special safety references.....	6
3	Introduction.....	8
3.1	Introduction	8
3.2	Special features	8
3.3	Technical details	9
4	Installation and putting into operation	12
4.1	Unwrapping	12
4.2	Installation	12
4.3	Electrical connection	12
4.4	Preparation of Using / Starting up	13
5	Operation.....	14
5.1	Operation elements.....	14
5.2	Operation	15
6	Maintenance	16
6.1	Cleaning and care.....	16
6.2	Trouble shooting	17
6.3	Wiring Diagrams.....	18
6.4	Spare Parts	20
6.5	Declaration of Conformity.....	25

2 Important References

2.1 Fundamental Safety Notes

2.1.1 Consider notes in the operating manual

- Precondition for the safe and trouble free use of this unit is the knowledge of the fundamental safety notes and safety regulations.
- The operating instruction contains the most important references to operate the unit safely.
- These operating instructions, particularly the safety references, are to be considered by all persons, who work on the unit.
- Furthermore the rules and regulations to avoid accidents are to be considered.

2.1.2 Obligation of the operator

The Operator is obliged to only let personnel work with the unit who:

- Are familiar with the fundamental regulations of work safety and accident avoiding and who have been instructed how to operate the unit.
- Read and understood the chapter about safety and warning notes and have confirmed this with their signature.

The safe conscious operation of the personnel has to be examined regularly.

2.1.3 Obligation of the personnel

All individuals who are authorized to work with the unit are obliged to:

- pay attention to the fundamental regulations of work safety and accident avoiding,
- read the chapter on work safety and warning notes in this manual and to confirm through their signature that they have understood these, before actually operating the unit.

2.1.4 Possible risks

The unit is built state of the art and in acknowledgement of all safety related rules. Nevertheless is it possible that danger for body and life of the user and/or third and/or impairments at the unit or at other real values merge. The unit is to be used only:

- For the due use.
- In safety related flawless condition.

Disturbances which can hurt the safety are to be eliminated immediately.

2.1.5 Due use

The unit is built exclusively for the preparation of food only. Any other uses of the unit are only allowed after consulting UBERT GASTROTECHNIK GMBH. Damages which result out of wrong use UBERT GASTROTECHNIK GMBH cannot be held responsible. Part of the due use is also:

- the consideration of all references of the operating manual and
- the observance of necessary maintenance and service.

2.2 Warranty and Liabilities

Fundamentally our "General terms of sale and delivery" count. These are known to the operator at the latest since signing of the contract. Claims to warranty and liability at persons- and property damages are impossible, if they are to be led back to one or several of the following causes:

- Non due use of the unit.
- Improper assembling, starting up, operating and servicing of the unit.
- Operating the unit with defective safety devices or safety devices which have not been installed properly and are in no working condition.
- Disobeyment of the references in the operating manual concerning transportation storage, installation, start-up, operation, maintenance and assembling of the unit.
- Unauthorized mechanical or electrical changes of the unit.
- Insufficient maintenance of wear and tear parts.
- Unauthorized repair.
- Force of nature and act of god.

2.3 Symbols and Notes

In the operating manual the following symbols and signs are used:



This symbol means a possibly or directly threatening danger for the life and the health of persons and/or a possibly dangerous situation.
Ignoring of these references may result in consequences for your health and/or can lead to property damages!



This symbol points to important references for the proper use of the unit.
Not paying attention to these references can lead to disturbances at the unit or in the environment!



This symbol points to operation tips and especially useful information.
Help to use all functions at your unit optimally!

2.4 Copyright

The copyright on this operating manual remains at the company UBERT GASTROTECHNIK GMBH. This operating manual is intended only for the operator and his personal. It contains instructions and references which neither completely nor partially:

- be duplicated,
- be circulated, or
- be otherwise made available to third parties.

Offences may violate applicable laws.



2.5 Special safety references

2.5.1 Safety devices

- Before operating the unit all protective devices as well as all removable parts must be installed correctly and be fully workable.
- Protective devices may only be removed:
After stand still and the prevention of unintentional restart.
- If partial components are delivered, an authorized staff member or service technician has to execute assembly according to installation guidelines.

2.5.2 Informal safety steps

- The operating manual is to be kept constantly accessible in the operating area.
- In addition to the operating manual all generally acknowledged and all local regulations for accident avoiding and environmental protection have to be applied with.
- All safety- danger labels at the unit are to be kept in readable condition.

2.5.3 Education of the personal

- Only trained and instructed personnel may work at the unit.
- The responsibilities of the personnel are to be determined clearly for installing, start-up, operation, assembling, and servicing of the unit.
- During instruction the personal may only work at the unit under supervision of an experienced person.

2.5.4 Controls

- Only instructed personal is allowed to operate the controls.

2.5.5 Safety during regular operation

- The unit is only to operate if all protective devices are fully workable.
- Before starting the unit it is to ensure, that nobody becomes endangered by the starting unit.
- At least once per shift the unit is to be examined with regard to visible damages and functional ability of the safety devices.

2.5.6 Danger caused by electric energy

- Any work on the electrical supply is to be executed only by a specialist.
- Likewise the electrical connection of this unit to the power supply must be executed by an electro-specialist; the connection must follow the rules of the local determinations.
- The electric installation is to be examined regularly. Loose connections and braised cables are to be eliminated immediately.
- If works at any life-parts are necessary, a second person who switches off the main switch if necessary is to consult.

2.5.7 Special danger-spots

- The water drawers are to be disassembled only at a switched off unit!
- Do not touch the hot heating elements!
- Do not touch the hot halogen lamps!

2.5.8 Service and maintenance, troubleshooting

- Prescribed adjustment, service and inspection work is to be accomplished timely by the manager or if necessary by an authorized service technician.
- The operating personal is to be informed before the beginning of the maintenance and service work.
- The unit is to be disconnected from the mains before maintaining, inspecting and repairing is performed; the main switch is to be guarded against unintended operation.
- Check all screw connections for tight fitting.
- After finishing maintenance check all safety devices for proper functionality.

2.5.9 Structural changes to the unit

- Do not perform any changes, extensions or conversions to the unit without the manufacturer's permission, especially welding work at supporting parts.
- For all conversions a written permission of the company UBERT GASTROTECHNIK GMBH is necessary.
- Change all parts of the unit, which are in improper condition.
- Use only original spare parts.

2.5.10 Cleaning of the unit and disposal of the waste

Used substances and materials are to be handled and disposed appropriately, especially lubricants. Detergents have to follow the rules of food-hygiene.

3 Introduction

3.1 Introduction

All Ubert - Deli Hot Displays operate with hot air convection. The air circulates slowly to minimize weight loss of the products. The temperature is regulated by Thermostat. Specially designed heating elements above the water drawers humidify the air that is moved by fans circulating in the cabinet. The optimized, constant climate guarantees long holding times at low quality-loss. To optimize the product presentation, the cabinet is equipped with effective halogen lighting. All Deli Hot Displays are equipped with a cutting board and drawers for cutlery and other small parts.

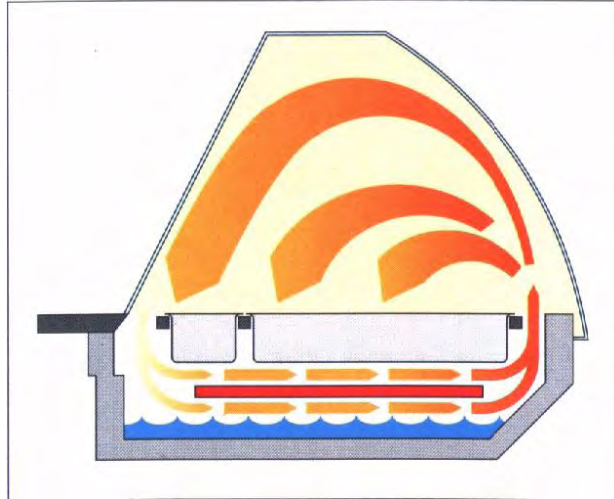

The maximum holding time depends on the kind of product and on the products starting temperature. It might be limited by national or local regulations. Never equip the cabinet with cold or deep frozen products.



3.2 Special features

- Ergonomical, stylish design
- Maximum product visibility by curved front glass
- Optically doubled food presentation by mirrored sliding doors
- Decorative stand (optional with bag shelf and bumpers)
- Easy handling of the curved front glass by pressure lifts (serve over units only)
- Optimized product-presentation by variable 100mm GN-pan equipment or decorative bowls.
- Meeting the hygienic requirements in accordance with HACCP
- All models are available as self-service equipment for impulse buying

3.3 Technical details

3.3.1 Dimensions [mm]

DHT 31 and DHT31SS (without stand):

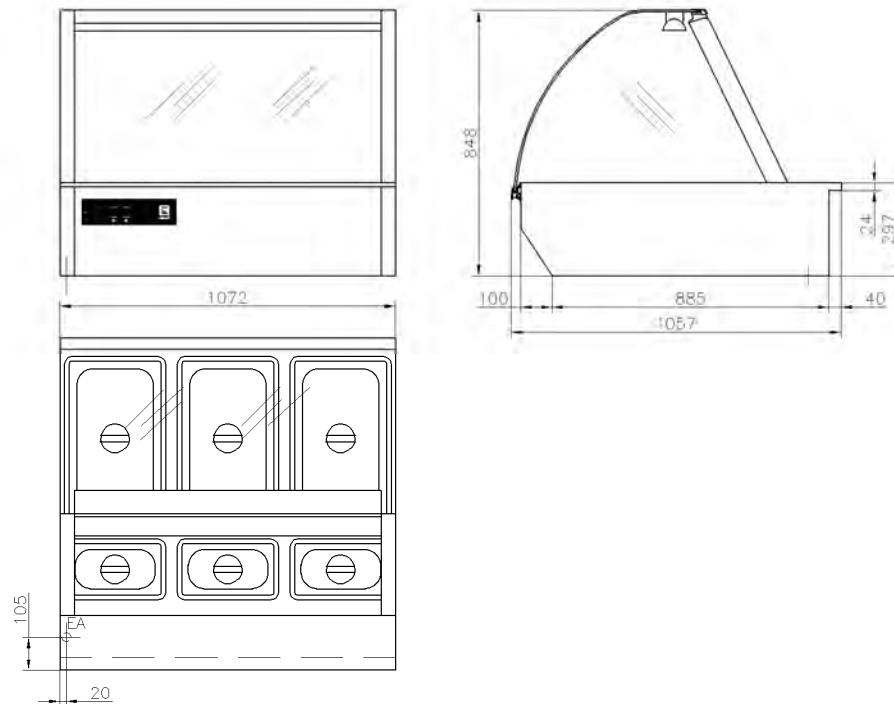

DHT 41 and DHT 41 SS (without stand):

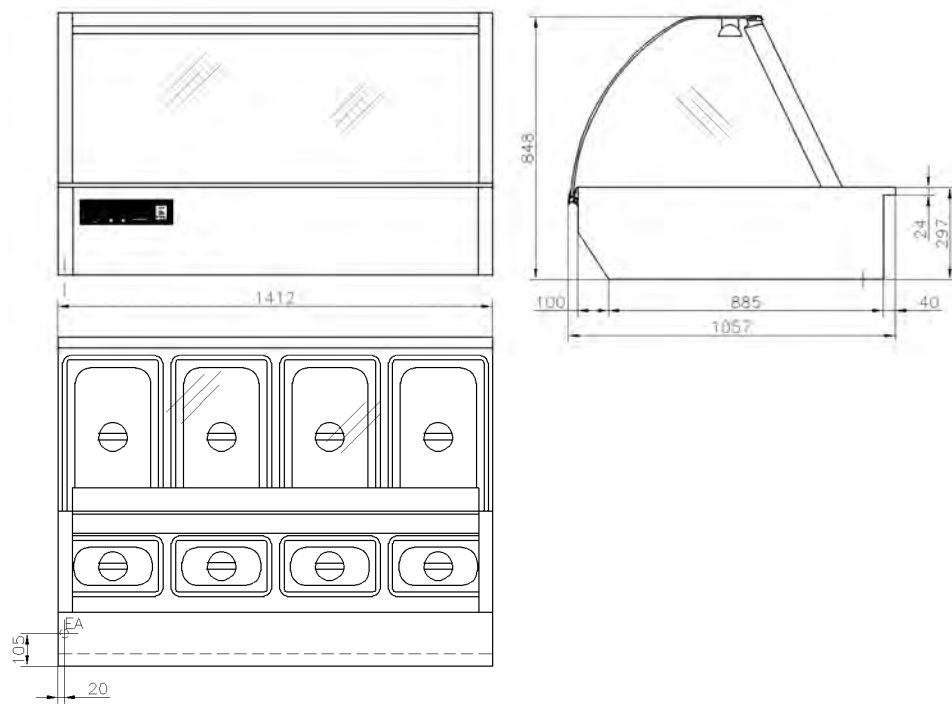

DHT 51 and DHT51SS (without stand):

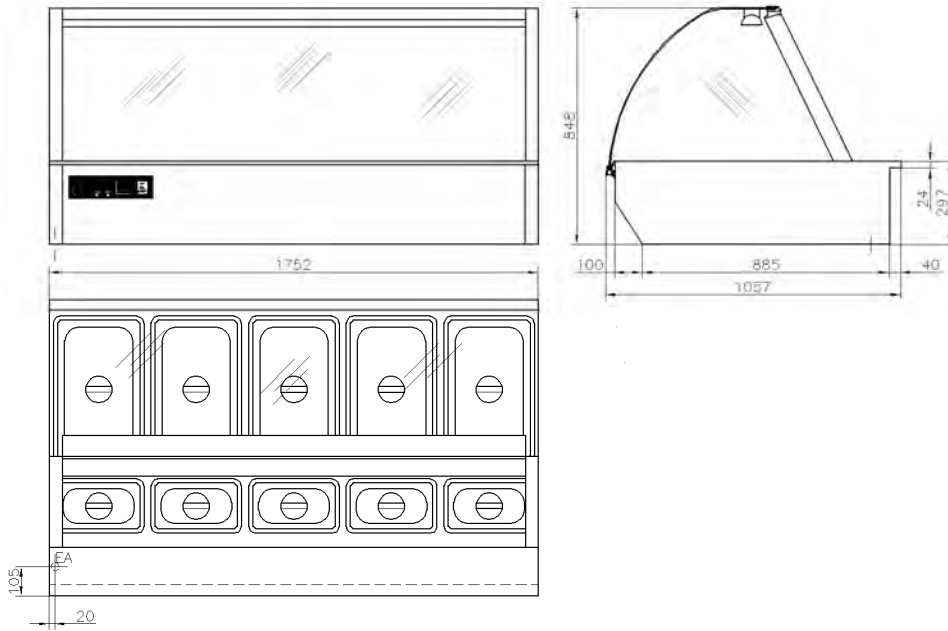

DHT 71 and DHT 71 SS (without stand):

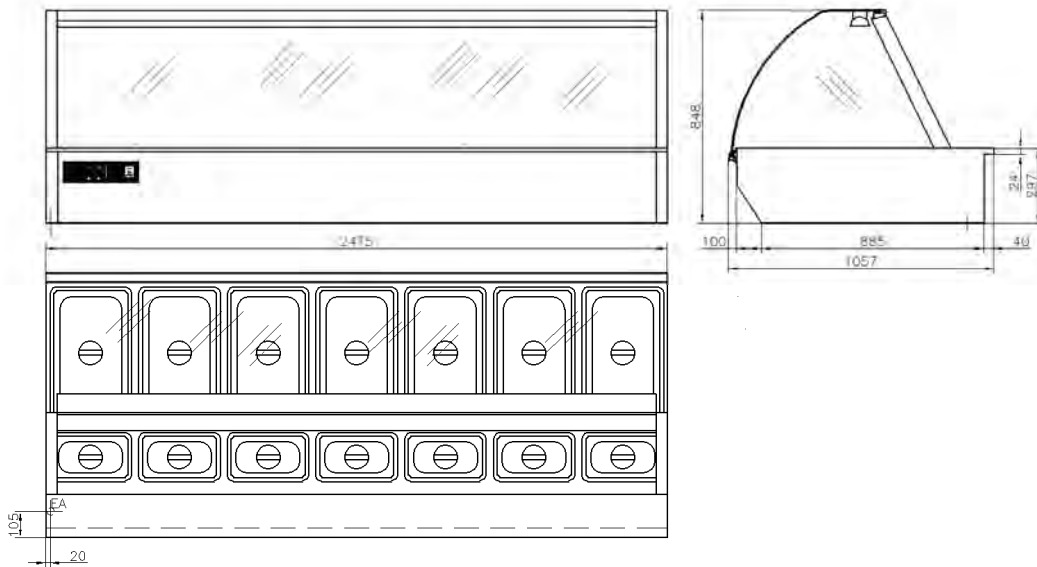

3.3.2 Weight

Type	Weight [kg]
DHT 31	ca. 120
DHT 31 SS	ca. 120
DHT 41	ca. 155
DHT 41 SS	ca. 155
DHT 51	ca. 200
DHT 51 SS	ca. 200
DHT 71	ca. 240
DHT 71 SS	ca. 240

3.3.3 Electrical Details, Power Consumption

Type	el. connection [EA]	power cons.
DHT 31	400V, 3/N, 50Hz	3.75kW
DHT 31 SS	400V, 3/N, 50Hz	3.75kW
DHT 41	400V, 3/N, 50Hz	5,10kW
DHT 41 SS	400V, 3/N, 50Hz	5,10kW
DHT 51	400V, 3/N, 50Hz	6.29kW
DHT 51 SS	400V, 3/N, 50Hz	6.29kW
DHT 71	400V, 3/N, 50Hz	8,39kW
DHT 71 SS	400V, 3/N, 50Hz	8,39kW

3.3.4 Noise emission

Type	noise emission
All types	< 70 dB (A)

4 Installation and putting into operation

In general all Deli Hot Cabinets will be packed for safely transport after the final control so that they will reach you properly. Nevertheless we ask you to have a look at the machine while unwrap it, whether it is really absolutely faultless.



Note! Visible faults have to be claimed immediately!

4.1 Unwrapping

- Open the carton and take out the wrapping material carefully.
- Take care that the delivery is complete (see attached freight papers).

4.2 Installation

Place the cabinet in the desired location. Make sure, that it is good visible for your customer to ensure good food presentation and successful sales.

Take care of the following points:

- The cabinet (with or without stand) has to be placed on a horizontal level Use a spirit level if necessary.
- Take care that both sides have at least 10 cm clear space to enable cleaning of the side glasses.
- If you have chosen permanent water drainage, provide a flexible tube-connection.
- There has to be enough free space to load, unload, clean and maintain the unit.
- The machine has to be placed so that the complete area around it can be cleaned easily.



4.3 Electrical connection

Note! In general, only service technicians of the company UBERT GASTRO-TECHNIK GMBH or service technicians of your responsible service partner are allowed to perform el. connection and other service! All national and local rules and regulations concerning electricity, fire protection and the like have to be considered. During any servicing, take care that the unit is disconnected from the mains! Not paying attention may result in injury!



Please learn the electrical data of your unit from the nameplate.

- Check whether your local electrical power supply is in accordance with the values on the name plate.
- Make sure the supply cable is protected as listed below:
5- wire, min. cross-section 1,5□) separately with 16 Amps.
- The power supply needs to be manufactured from heat resistant, flexible cable. It is to be routed to prevent any contact to hot parts.
- The unit is to be connected to the power supply either by means of an appropriate plug or if connected permanently, a switch (interrupting all poles) is to be provided. In case of an emergency the power supply must be interruptible immediately.
- For further information please see the wiring diagram (below).

Note!

After finishing any installation work, maintenance or repair, check whether the ground wires are connected properly to the casing and the side covers.



4.4 Preparation of Using / Starting up

Before you can use the Cabinet you have to clean all removable parts carefully with a grease solvent.

Note! Do not use flammable cleaners. Do not use high-pressure cleaning machines, water pressure cleaning machines or steam jet cleaning machines. You will have further information about this in the section „cleaning and up keeping“.



After cleaning the Cabinet properly the smell will be minimal when using it the first time.

5 Operation

Following you will find explanation and location of all components and their function for the use of the cabinet.

5.1 Operation elements



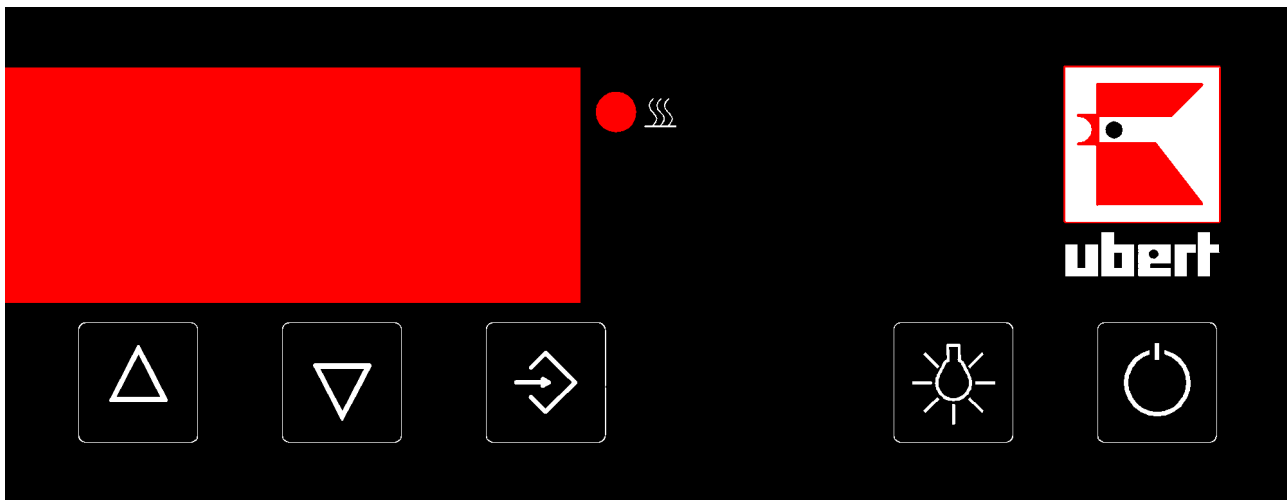



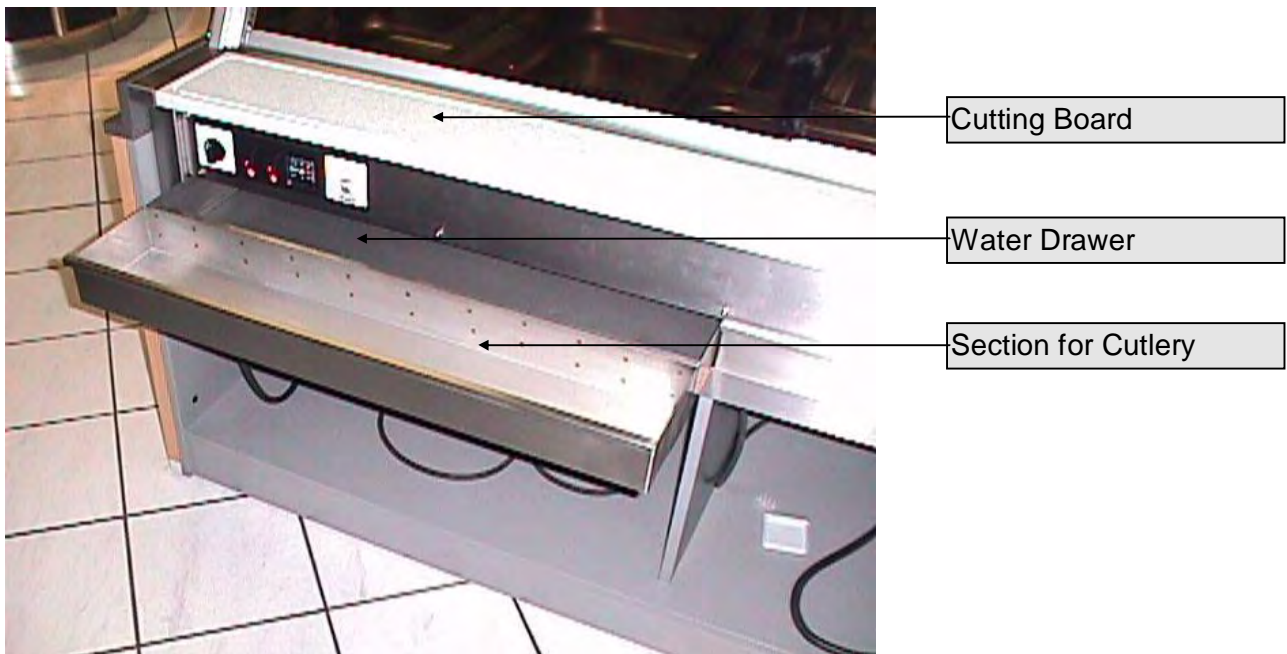





Digital Control



Other



5.2 Operation

<p>STANDBY button</p> 	Switches the cabinet ON and OFF.	
<p>LIGHT Button</p> 	Switches the lights inside the cabinet ON and OFF.	
<p>PPROGRAMMING button</p> 	Keep pushed to change the set temperature using  and  .	
<p>UP button</p> 	While  is pushed, use the UP button to increase the set temperature.	
<p>DOWN Button</p> 	While  is pushed, use the DOWN button to decrease the set temperature. Also used to quit alarms.	
<p>HEATING Symbol</p> 	Is illuminated whenever the actual temperature is below the set temperature and the heating elements are running.	
<p>DISPLAY</p> 	The DISPLAY shows the actual temperature. While  is pushed, it shows the set temperature. While the Cabinet is switched off the display shows "OFF"	
<p>Water Drawers:</p>	Fill with water to increase air humidity in the cabinet. It is located behind the section for cutlery. Pull out carefully to fill.	
<p>Section for Cutlery</p>	Use this space to store the tools you require during operation.	
<p>Cutting Board:</p>	<p>Workspace to cut your products and do various other handling during loading, unloading, packing and the like.</p> <p>Note! Do not place hot GN-pans or other hot items on the cutting board.</p>	

6 Maintenance

Following we will show you some advices concerning maintenance, care, trouble shooting and service for the cabinet.

6.1 Cleaning and care

6.1.1 Safety advices

- Before you start to clean and care switch off the appliance and disconnect it from the mains.
- Do not use inflammable detergents cleaners. Never use high-pressure-, water pressure- or steam jet- cleaning machines. You will find further information in the chapter concerning cleaning.
- Wear fire safe, insulated gloves to prevent burnings when touching hot parts.
- Wear acid proof gloves while cleaning the cold parts to prevent skin irritations.



6.1.2 General Recommendations

- The unit has to be cleaned daily.
- Only use cleaners that are appropriate for food.
- After cleaning with special cleaners you have to wash all parts with clear water and dry them afterwards so that there are no residues of the cleaner on these parts.
- Only use cleaners that are appropriate for food.
- After cleaning with special cleaners you have to wash all parts with clear water and dry them afterwards so that there are no residues of the cleaner on these parts.
- It is absolutely necessary to watch out for some fundamental things to keep this long living high-grade-steel-machine working:
 - always keep the high-grade-steel surface clean.
 - watch out that there is always enough fresh air on the surface
 - never contact the surface with rusty material
- Never use bleaching or chlorine cleaners.



6.1.3 Detergents

To make the cleaning fast and easy we have integrated some cleaners in our program:

- Grill- and oven cleaner:
To dispose persistent, dried-up dirt on metal surfaces.
- Intensive-cleaner:
Detergent for metal- and plastic-surfaces.
- Glass-cleaner:
Removes fat from glass-surfaces.
- Stainless steel-cleaner:
You have to spray this from a distance of app. 25 cm on the surface and wipe it off with a dry cleaning rag. If you want to clean only small parts you have to spray it directly on the cleaning rag and wipe it off this way. With this method it is possi-



ble to clean easily and without stripes.

6.1.4 Special Cleaning tips

Please find below some special cleaning tips for this specific unit.

- Lamps:
To be cleaned only with soft paper or cloth and alcohol.
- Glass:
Lift the curved front glass to clean the inside. Due to the pressure lifts it is easy to lift the curved front glass on serve over units. However, the opened glass should be secured by hand. Remove dust and dirt from the glass surface with soft cloth to avoid scratches.
- Drawers, GN-Pans:
Easily removable without tools for separate cleaning.
- Crumbtray, Louvers:
To be cleaned regularly to ensure a proper air circulation. The louvers are located at the customer's side of the cabinet. The Crumbtray is located underneath the louvers to catch any parts fallen through the louvers.



6.2 Trouble shooting

In case your cabinet does not work properly, we would like to give a first help with the following checklist. Only after checking these points you should contact:

a) Your responsible service partner

Or

b) Directly the company: UBERT GASTROTECHNIK GmbH
Werk II Gewerbegebiet Nord
Vennekenweg 17
46348 Raesfeld
Tel: (49) 02865 / 602-226
Service-Tel: 0172 / 2 82 86 31
Fax: (49) 02865 / 602-102 (or -103)

Only these two companies are allowed to carry out service work and replacement of defect parts. If you do not observe this note or in case of manipulation of a third party any claims for guarantee will become invalid!



6.2.1 Error messages

Message	Means	What to do
F1L in the Display	Temperature probe is short circuited	Call for service
F1H in the Display	Temperature probe is broken	Call for service
EP in the Display	Parameters lost	Call for service
Flashing Temperature in the Display	Temperature alarm	Quit alarm pushing the DOWN button; check temperature settings; call for service
Beeper sounds	Temperature alarm	Quit alarm pushing the DOWN button; check temperature settings; call for service

6.3 Wiring Diagrams

6.3.1 DHT 31 and DHT31SS 400V / 50Hz / 3/N

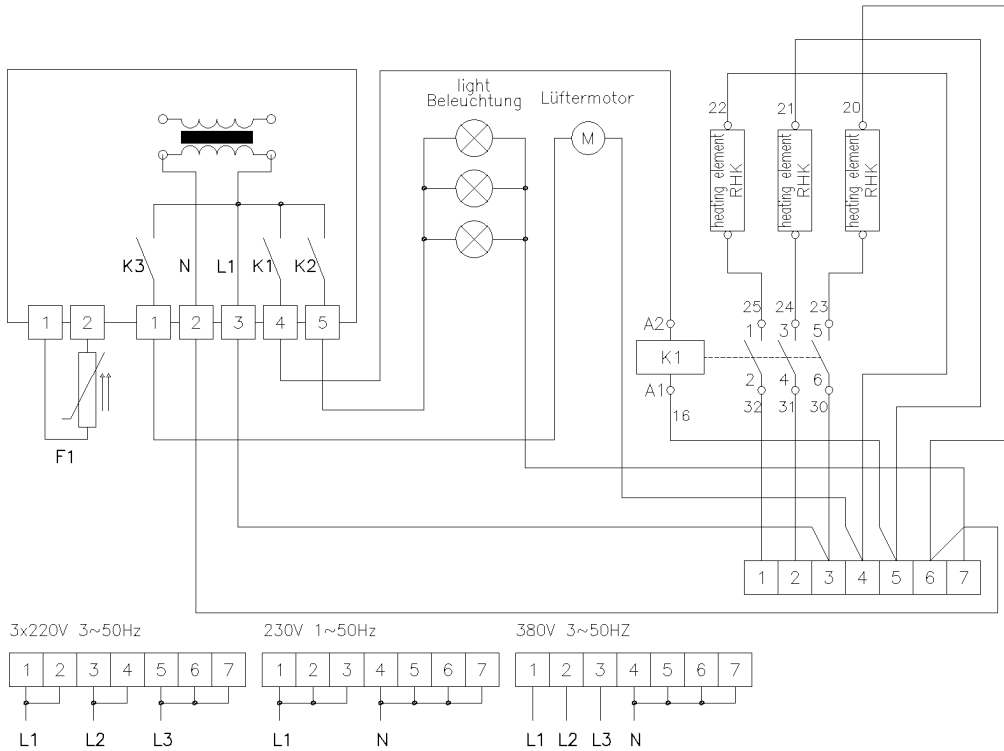

6.3.2 DHT 41 and DHT41SS 400V / 50Hz / 3/N

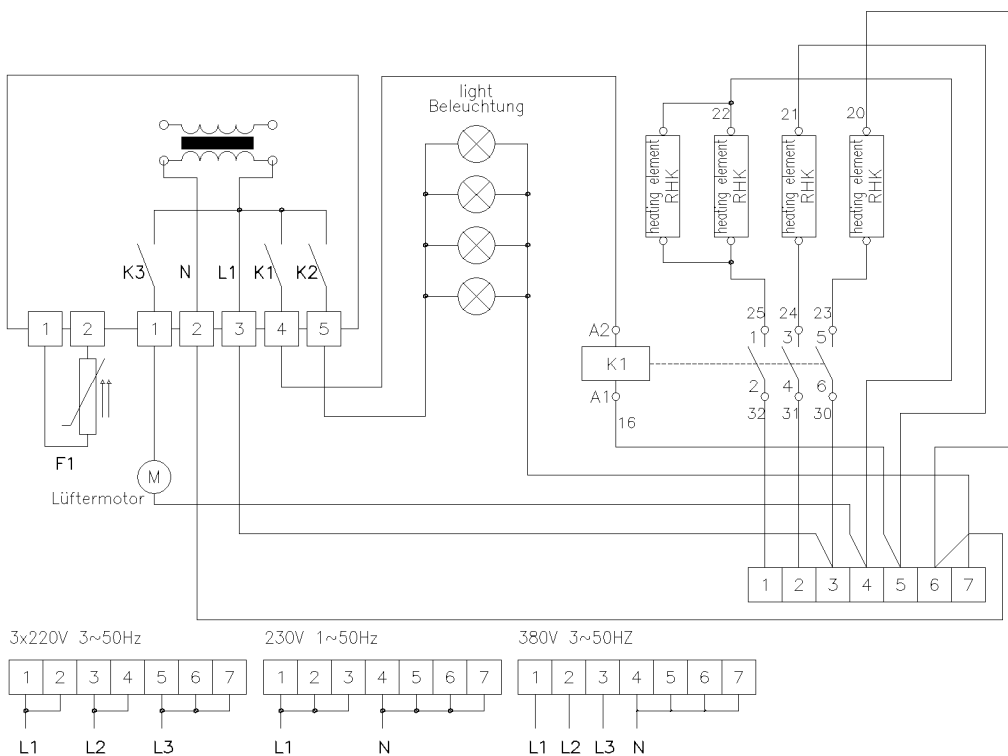

6.3.3 DHT 51 and DHT51SS 400V / 50Hz / 3/N

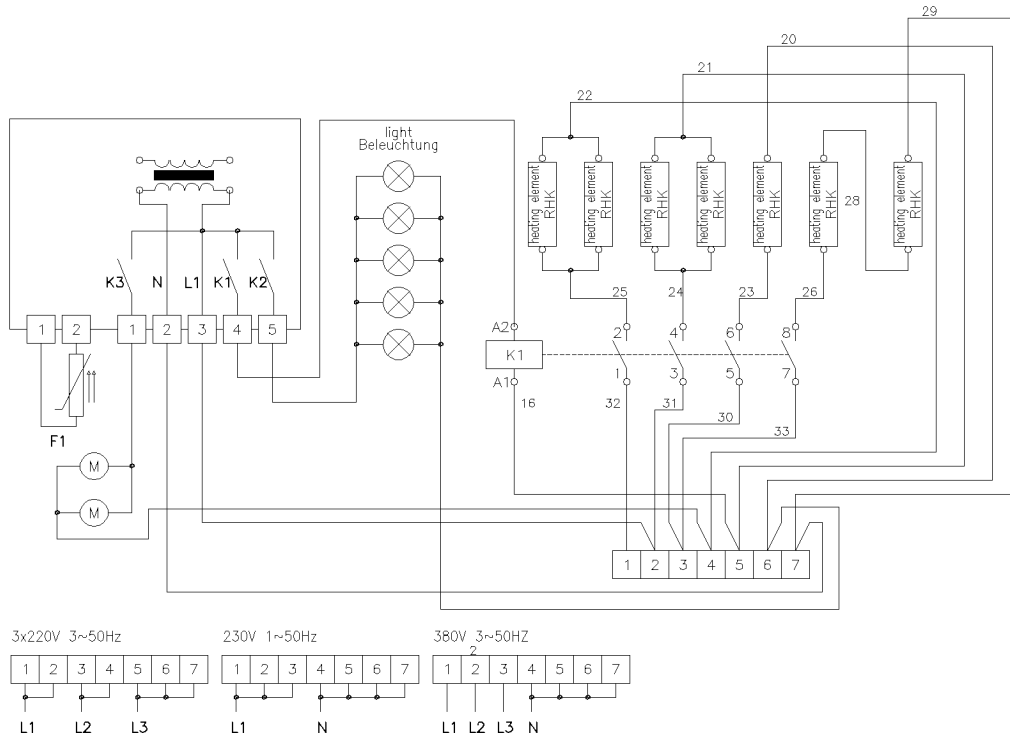

6.3.4 DHT 71 and DHT71SS 400V / 50Hz / 3/N

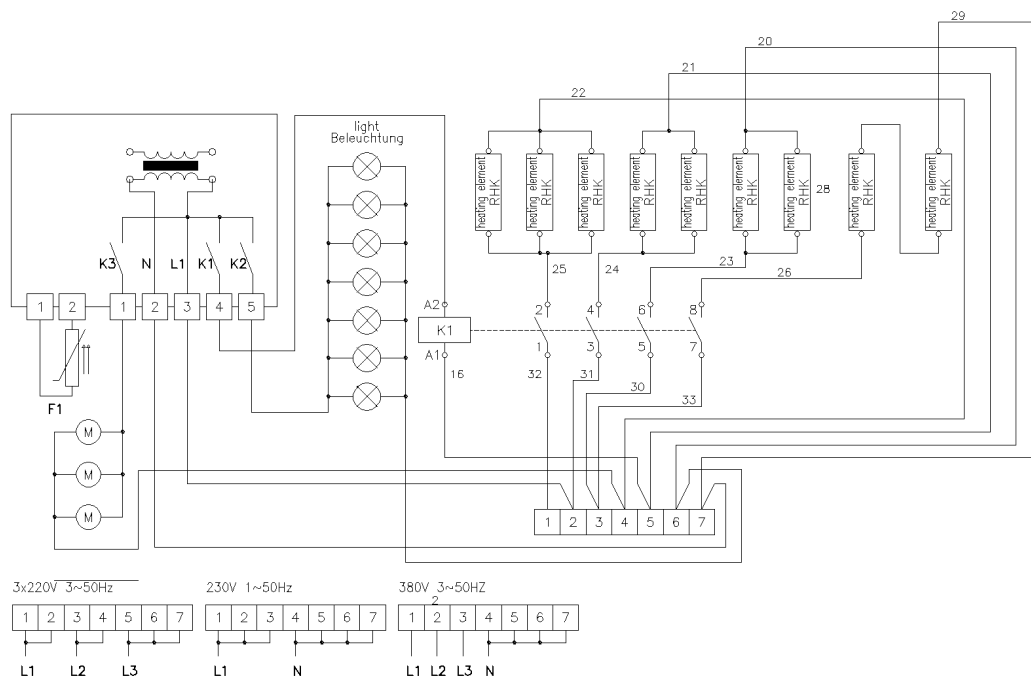

6.4 Spare Parts

Defect parts are to be replaced only by original spare parts of the company UBERT GASTROTECHNIK GMBH; the replacement is to be carried out only by their service personal or by your authorized Service companies. Only these two companies are allowed to carry out service work and replacement of defect parts. If you do not observe this note or in case of manipulation of a third party any claims for guarantee will become invalid! Also all certifications (CE, UL, NSF and the like) become invalid!



6.4.1 Explosion Diagram

DHT and DHTSS-Series

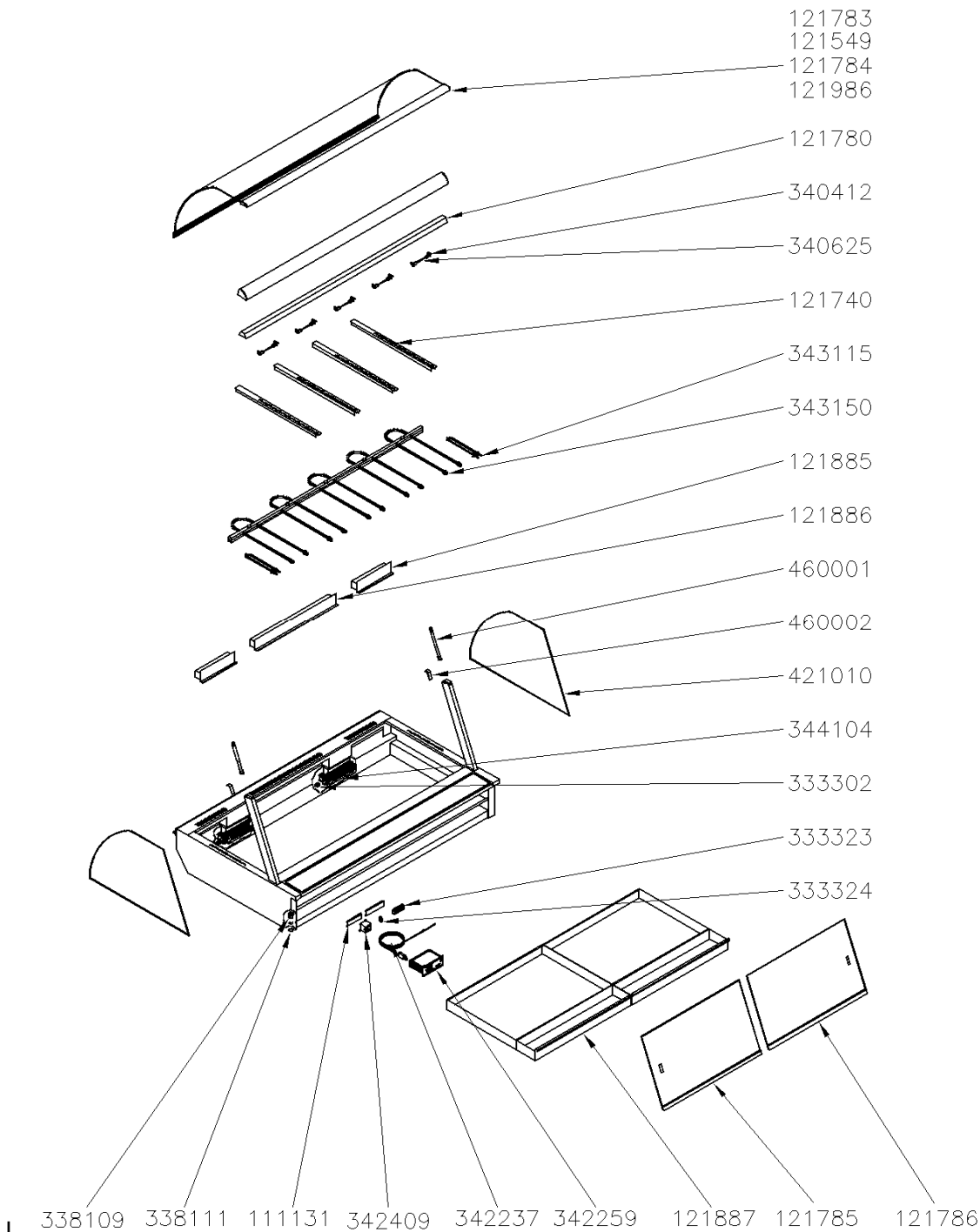

6.4.2 Spare Parts List

DHT31 and DHT31SS

Amount	Part No.	Description	VT
1	121757	crumb drawer	
2	121799	water drawer	
1	121740	intermediate rail	
1	342259	Digital Control for HT, DHT	
1	342237	Temperature probe PT100	
2	460101	Pressure lift 400N, Type 25	
2	460002	lighting screen holder	
1,2	460011	Seal, Front for all Deli Series	X
4	361508	flange - Teflon, black	
2	421010	side glass for DHT/DKT 31/41/51	
1	121777	guide blade	
1	121778	guide blade (954), below	
1	121785	sliding door left for DHT 31	
1	121786	sliding door right for DHT 31	
1	121783	front glass assy DHT/DKT 31	
8	361502	Rubber stopper black	
1	344104	cross-flow fan, for HT / DHT	
3	343150	heating element 1150W DHT 31/51	
1	121780	Reflektor für Lampenschirm	
6	340412	Lampsocket for halogenlamp with R7s connector	
3	340625	halogen lamp 150W	
2	333302	terminal block	
1	342409	contactor	
6	333323	Terminal block 4qmm 4-pole	
1	333324	End cap for terminal block 4qmm 333323	
1	338109	Strain relief main cord	
1	338111	Strain relief counter nut	
2	111131	track for terminal blocks	

DHT41 and DHT41SS

Amount	Part No.	Description	VT
2	122321	crumbdrawer small	
1	122322	crumb drawer big	
1	121529	water drawer	
3	121874	intermediate rail for DHT 41/51	
1	342259	Digital Control for HT, DHT	
1	342237o	Temperature probe PT100	
2	460001	Pressure lift 700N, type 25, DHT/DKT51	
2	460002	lighting screen holder	
1	121549	front glass assy DHT/DKT41	
1,41	460011	Seal, Front for all Deli Series	X
4	361508o	flange - Teflon, black	
2	421010	side glass for DHT/DKT 31/41/51	
1	121777	guide blade	
1	121778	guide blade (954), below	
1	121547	sliding door left for DHT41	
1	121548	sliding door right for DHT41	
8	361502	Rubber stopper black	
2	344104	cross-flow fan, for HT / DHT	
4	343150	heating element 1150W DHT 31/51	
1	121550	reflector for lampshade	
8	340412o	Lampsocket for halogenlamp with R7s connector	
4	340625	halogen lamp 150W	
2	333302	terminal block	
1	342409o	contactor	
6	333323	Terminal block 4qmm 4-pole	
1	333324	End cap for terminal block 4qmm 333323	
1	338109o	Strain relief main cord	
1	338111o	Strain relief counter nut	
2	111131	track for terminal blocks	

DHT51 and DHT51SS

Amount	Part No.	Description	V T
2	121885	crumbdrawer small	
1	121886	crumb drawer big	
2	121887	water drawer	
4	121874	intermediate rail for DHT 41/51	
1	342259	Digital Control for HT, DHT	
1	342237o	Temperature probe PT100	
2	460001	Pressure lift 700N, type 25, DHT/DKT51	
2	460002	lighting screen holder	
1	121784	front glass assy DHT/DKT 51	
1,98	460011	Seal, Front for all Deli Series	X
2	421010	side glass for DHT/DKT 31/41/51	
4	361508o	flange - Teflon, black	
1	121746	guide blade top DHT51	
1	121748	guide blade below DHT51	
1	121787	sliding door left for DHT 51	
1	121788	sliding door right for DHT 51	
2	344104	cross-flow fan, for HT / DHT	
2	343115	heating element 1000W DHT 51	
5	343150	heating element 1150W DHT 31/51	
1	121750	Track for terminal block	
1	121751	reflector	
10	340412o	Lampsocket for halogenlamp with R7s connector	
5	340625	halogen lamp 150W	
3	333302	terminal block	
1	342409o	contactor	
7	333323	Terminal block 4qmm 4-pole	
1	333324	End cap for terminal block 4qmm 333323	
1	338109o	Strain relief main cord	
1	338111o	Strain relief counter nut	

DHT71 and DHT71SS

Amount	Part No.	Description	VT
2	121885	crumbdrawer small	
2	121886	crumb drawer big	
1	121984	water drawer	
6	121874	intermediate rail for DHT 41/51	
1	342259	Digital Control for HT, DHT	
1	342237o	Temperature probe PT100	
8	460207	Pressure lift 400N	
1	121986	Frontglas curved DHT/DKT 71, assembly	X
2	421107	side glass for DHTG31/41/51/71	X
2	121988	guide blade	
2	121989	guide plate (1188), below	
2	121990	sliding door left for DHT 71	
2	121992	sliding door right for DHT 71	
8	361502	Rubber stopper black	
3	344104	cross-flow fan, for HT / DHT	
2	343115	heating element 1000W DHT 51	
7	343150	heating element 1150W DHT 31/51	
1	121750	Track for terminal block	
1	121751	reflector	
14	340412o	Lampsocket for halogenlamp with R7s connector	
7	340625	halogen lamp 150W	
7	333302	terminal block	
1	342404	Contactactor	
7	333323	Terminal block 4qmm 4-pole	
1	333324	End cap for terminal block 4qmm 333323	
1	338109o	Strain relief main cord	
1	338111o	Strain relief counter nut	

6.5 Declaration of Conformity

UBERT GASTROTECHNIK GMBH
Gewerbegebiet Ost + Nord
D-46348 Raesfeld

Telefon: +49 (0) 28 65 / 602-0
Fax: +49 (0) 28 65 / 602-102
Internet: www.ubert.com
e-mail: info@ubert.com



CE KONFORMITÄTSERKLÄRUNG DECLARATION OF CONFORMITY CERTIFICAT DE CONFORMITÉ

Hereby we declare that the unit noted below, on the basis of its concept, design and version, meets all basic health and safety requirements of the applicable EC-directive. This declaration is no longer effective in case this machine has been modified without our approval.

Product designation: Hot Deli Display Cabinet

Model: DHT 31 / DHT 31 SS
DHT 41 / DHT 41 SS
DHT 51 / DHT 51 SS
DHT 71 / DHT 71 SS

EC-directives followed: EC-directive for machines 2006/42/EG
EC-directive for low voltage 2006/95/EG
Electromagnetic compatibility 2004/108/EG

Harmonized European Standards: EN 55014 Electromagnetic compatibility – Requirements for household appliances
EN 61000-6-2 Electromagnetic compatibility – Generic immunity standard
EN 60335-1 Safety of household and similar electrical appliances
EN 60335-2 Safety of household and similar electrical appliances

Applied national standards and technical specifications: BGR111 directions for safety and health protection regarding kitchen work
VDE 0700 Safety of household and similar electrical appliances

This declaration does not include any assurance of characteristics.

The safety references enclosed with the product documentation have to be followed.

By internal actions it is guaranteed, that all serial units meet the demands of the corresponding EC directive and the applied standards.

The signers are entitled to compose the technical documents.

Raesfeld, 01.01.10
UBERT GASTROTECHNIK GMBH

Christoph Stephan
Vice President, R&D / Engineering

Raesfeld, 01.01.10
UBERT GASTROTECHNIK GMBH

Michael Peters
Service - Manager

Manufactured by: UBERT GASTROTECHNIK GMBH
Gewerbegebiet Ost + Nord
D-46348 Raesfeld