



Register Online!  
¡Regístrese en línea!  
S'inscrire en ligne!



# GLO-RAY®

## GR, GRH, GRA, GRAH, GRAL, GRAHL, GRN, and GRNH Series

I&W #07.05.266.00  
(1 of 2)

### GB Infrared Strip Heaters

GR Series

Installation and Operating Manual

For CE and Non-CE Models

P 2

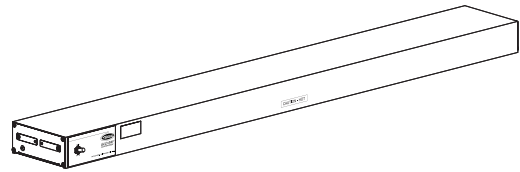

### E Calentadores de banda Infrared

GR Serie

Manual de Instalación y Operación

Para modelos CE y no CE

P 31

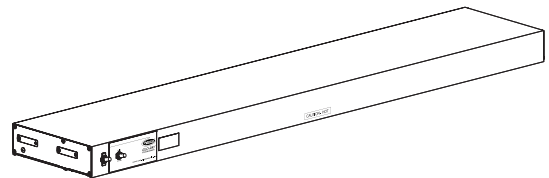

### F Rampes chauffantes à infrarouge

GR Série

Manuel d'installation et d'utilisation

Pour les modèles CE et non-CE

P 59

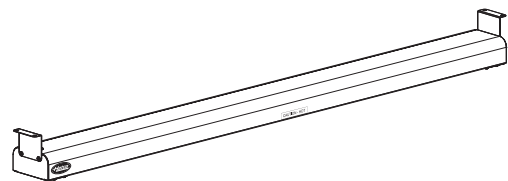
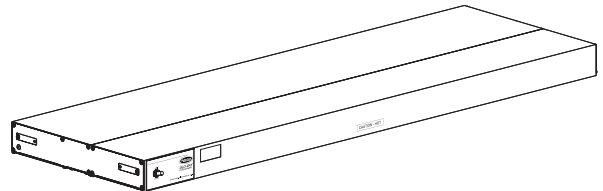

#### ⚠ WARNING

Do not operate this equipment unless you have read and understood the contents of this manual! Failure to follow the instructions contained in this manual may result in serious injury or death. This manual contains important safety information concerning the maintenance, use, and operation of this product. If you're unable to understand the contents of this manual, please bring it to the attention of your supervisor. Keep this manual in a safe location for future reference.

#### ⚠ ADVERTENCIA

No opere este equipo al menos que haya leído y comprendido el contenido de este manual! Cualquier falla en el seguimiento de las instrucciones contenidas en este manual puede resultar en un serio lesión o muerte. Este manual contiene importante información sobre seguridad concerniente al mantenimiento, uso y operación de este producto. Si usted no puede entender el contenido de este manual por favor pregunte a su supervisor. Almacenar este manual en una localización segura para la referencia futura.

#### ⚠ AVERTISSEMENT

Ne pas utiliser cet équipement sans avoir lu et compris le contenu de ce manuel ! Le non-respect des instructions contenues dans ce manuel peut entraîner de graves blessures ou la mort. Ce manuel contient des informations importantes concernant l'entretien, l'utilisation et le fonctionnement de ce produit. Si vous ne comprenez pas le contenu de ce manuel, veuillez le signaler à votre supérieur. Conservez ce manuel dans un endroit sûr pour pouvoir vous y référer plus tard.

<b>Important Owner Information</b> .....	<b>2</b>	Installing Portable Units.....	21
<b>Introduction</b> .....	<b>2</b>	Installing Chain Suspended Units .....	22
<b>Important Safety Information</b> .....	<b>3</b>	Installing Permanent Units .....	23
<b>Model Description</b> .....	<b>4</b>	Electrical Information .....	25
<b>Model Designation</b> .....	<b>4</b>	<b>Operation</b> .....	<b>26</b>
<b>Specifications</b> .....	<b>5</b>	General.....	26
Plug Configurations .....	5	<b>Maintenance</b> .....	<b>27</b>
Electrical Rating Chart.....	5	General.....	27
Dimensions.....	17	Cleaning .....	27
<b>Installation</b> .....	<b>18</b>	Replacing a Display Light.....	27
General.....	18	<b>Troubleshooting Guide</b> .....	<b>28</b>
Recommended Mounting Heights .....	19	<b>Options and Accessories</b> .....	<b>28</b>
Minimum Clearance Requirements for Combustible		<b>International Limited Warranty</b> .....	<b>30</b>
Surroundings .....	19	<b>Service Information</b> .....	<b>30</b>
Minimum Clearance Requirements for			
Non-Combustible Surroundings .....	20		

**IMPORTANT OWNER INFORMATION**

Record the model number, serial number (specification label located on the side of the unit), voltage, and purchase date of the unit in the spaces below. Please have this information available when calling Hatco for service assistance.

Model No. \_\_\_\_\_

Serial No. \_\_\_\_\_

Voltage \_\_\_\_\_

Date of Purchase \_\_\_\_\_

Business Hours: 8:00 AM to 5:00 PM  
Central Standard Time (C.S.T.)  
  
(Summer Hours: June to September—  
8:00 AM to 5:00 PM C.S.T.  
Monday through Thursday  
8:00 AM to 2:30 PM C.S.T. Friday)

Telephone: (414) 671-6350

E-mail: [partsandservice@hatcocorp.com](mailto:partsandservice@hatcocorp.com)

Fax: (414) 671-3976 (Parts and Service)

Additional information can be found by visiting our web site at [www.hatcocorp.com](http://www.hatcocorp.com).

**Register your unit!**

Completing online warranty registration will prevent delay in obtaining warranty coverage. Access the Hatco website at [www.hatcocorp.com](http://www.hatcocorp.com), select the *Parts & Service* pull-down menu, and click on "Warranty Registration".

**INTRODUCTION**

Glo-Ray® Infrared Strip Heaters ensure maximum food holding time and minimize the risk of food-borne illness. Optimum safety and quality is the result of food held at the proper serving temperatures using Glo-Ray’s pre-focused heat patterns. The pre-focused heat pattern prevents foods from being over-cooked in the middle and cooling off around the edges by concentrating higher temperatures to the outer edges of holding surfaces where heat loss is the greatest. Utilizing specially designed reflectors to direct the heat from the element, Glo-Ray Strip Heaters safely maintain peak serving temperatures longer without cooking the food beyond the point of excellence.

Glo-Ray Infrared Strip Heaters are available from the factory with or without shatter-resistant incandescent lights to illuminate the warming area. These bulbs have a special coating that guards against injury and food contamination in the event of breakage.

Glo-Ray Infrared Strip Heaters are products of extensive research and field testing. The materials used were selected for maximum durability, attractive appearance and optimum performance. Every unit is inspected and tested thoroughly prior to shipment.

This manual provides installation, safety, and operating instructions for Glo-Ray Strip Heaters. Hatco recommends all installation, operating, and safety instructions appearing in this manual be read prior to installation or operation of a unit.

Safety information that appears in this manual is identified by the following signal word panels:



**WARNING** indicates a hazardous situation which, if not avoided, could result in death or serious injury.



**CAUTION** indicates a hazardous situation which, if not avoided, could result in minor or moderate injury.



**NOTICE** is used to address practices not related to personal injury.



Read the following important safety information before using this equipment to avoid serious injury or death and to avoid damage to equipment or property.

### WARNING

#### ELECTRIC SHOCK HAZARD:

- Units supplied without an electrical cord and plug require a hardwired connection to the on-site electrical system. Connection must be properly grounded and of the correct voltage, size, and configuration for the electrical specifications of the unit. Contact a qualified electrician to determine and install the proper electrical connection.
- Plug unit into a properly grounded electrical receptacle of the correct voltage, size, and plug configuration. If plug and receptacle do not match, contact a qualified electrician to determine and install proper voltage and size electrical receptacle.
- Turn OFF power switch, unplug power cord/turn off power at circuit breaker, and allow unit to cool before performing any cleaning, adjustments, or maintenance.
- DO NOT submerge or saturate with water. Unit is not waterproof. Do not operate if unit has been submerged or saturated with water.
- Do not steam clean or use excessive water on unit.
- This unit is not “jet-proof” construction. Do not use jet-clean spray to clean this unit.
- Discontinue use if power cord is frayed or worn.
- Do not attempt to repair or replace a damaged power cord. Cord must be replaced by Hatco, an Authorized Hatco Service Agent, or a person with similar qualifications.
- Use only Genuine Hatco Replacement Parts when service is required. Failure to use Genuine Hatco Replacement Parts will void all warranties and may subject operators of the equipment to hazardous electrical voltage, resulting in electrical shock or burn. Genuine Hatco Replacement Parts are specified to operate safely in the environments in which they are used. Some aftermarket or generic replacement parts do not have the characteristics that will allow them to operate safely in Hatco equipment.

#### FIRE HAZARD:

- Locate unit the correct distance from combustible walls and materials. If safe distances are not maintained, discoloration or combustion could occur. Refer to specific installation and mounting information in this manual for proper clearances.
- Make sure to follow the installation information listed below for specific strip heaters. If safe distances are not maintained, discoloration or combustion could occur.
  - Do not install standard wattage strip heaters (GR, GRA, GRN, GRAL Series) less than 254 mm (10”) above combustible surfaces.
  - Do not install high wattage strip heaters (GRH, GRAH, GRNH, GRAHL Series) less than 343 mm (13-1/2”) above combustible surfaces.
  - Do not install dual strip heaters (GRA-XXD, GRAH-XXD, GRAL-XXD, and GRAHL-XXD Series) above combustible surfaces.
  - Install all single strip heaters with a minimum distance of 76 mm (3”) from a combustible wall or adjacent surface.

Use only light bulbs that meet or exceed National Sanitation Foundation (NSF) standards and are specifically designed for food holding areas. Breakage of light bulbs not specially-coated could result in personal injury and/or food contamination.

### WARNING

**EXPLOSION HAZARD:** Do not store or use gasoline or other flammable vapors or liquids in the vicinity of this or any other appliance.

This unit is not intended for use by children or persons with reduced physical, sensory, or mental capabilities. Ensure proper supervision of children and keep them away from the unit.

Make sure all operators have been instructed on the safe and proper use of the unit.

Make sure food product has been heated to the proper food-safe temperature before placing in unit. Failure to heat food product properly may result in serious health risks. This unit is for holding pre-heated food product only.

For installation with chains, make sure the chains have sufficient strength and are securely fastened to both the strip heater and the mounting location. Poorly installed chains may cause the heater to loosen and fall. Do not place anything on top of heaters installed with chains.

This unit has no “user-serviceable” parts. If service is required on this unit, contact an Authorized Hatco Service Agent or contact the Hatco Service Department at 414-671-6350 or International fax 414-671-3976.

### CAUTION

**BURN HAZARD:** Some exterior surfaces on the unit will get hot. Use caution when touching these areas.

Standard and approved manufacturing oils may smoke up to 30 minutes during initial startup. This is a temporary condition. Operate unit without food product until smoke dissipates.

Strip heaters equipped with incandescent lights that require a circuit breaker larger than 20 amps for the heat element must have a separate circuit breaker for the incandescent lights that is 20 amps or less.

Ensure safe and proper operation. Refer to the “Minimum Clearance Requirements” listed in the Installation section of this manual.

### NOTICE

Installation of two or more separate units with less than 3” (76 mm) between housings may result in premature failure of component parts. Failure to provide proper spacing may result in heat damage to electrical components.

Units are voltage-specific. Refer to specification label for electrical requirements before beginning installation.

Do not add a decorative soffit to hide a pass-through mounted strip heater. Excessive heat can cause unit failure.

To prevent premature failure of components due to excessive heat, remote mounted control switches must be installed outside the strip heater heat zone.

Damage to countertop material caused by heat generated from Hatco equipment is not covered under the Hatco warranty. Contact the manufacturer of the countertop material for application information.

Use non-abrasive cleaners and cloths only. Abrasive cleaners and cloths could scratch the finish of the unit, marring its appearance and making it susceptible to soil accumulation.

# MODEL DESCRIPTION



## All Models

Hatco Glo-Ray® Infrared Strip Heaters keep hot foods at optimum serving temperatures longer. Foods do not dry out or become discolored; even the most delicate dishes hold that “just-prepared” look. The Glo-Ray pre-focused heat pattern directs heat from a tubular element to bathe the entire holding surface.

Glo-Ray strip heaters can be ordered in standard or high wattage configurations, aluminum housings in lengths of 457–3658 mm (18”–144”), stainless steel housings in lengths of 610–2438 mm (24”–96”), or narrow design stainless steel housings in lengths of 457–1829 mm (18”–72”).

All strip heaters have several mounting options and switch locations. Optional infinite control switches, remote control enclosures, incandescent lighting, and sneeze guards are also available.

## GR-XX, GRL-XX, GRH-XX, and GRHL-XX Models

Stainless steel models are available with or without incandescent lights

*NOTE: Stainless steel strip heaters are not available with sneeze guards or as dual units.*

## GRA-XX, GRAH-XX, GRAL-XX, and GRAHL-XX Models

Aluminum, single element models are available either with or without incandescent lights.

## GRA-XXD, GRAH-XXD, GRAL-XXD, and GRAHL-XXD Models

Dual models allow for side-by-side mounting of two or more strip heaters to provide a wider holding area (dual models are constructed with a required 76 mm [3”] or 152 mm [6”] spacer between heating elements).

Aluminum, dual element models are available either with or without incandescent lights.

*NOTE: Incandescent lights and sneeze guards are not available for retrofit.*

## GRN-XX and GRNH-XX Models

Narrow models are available in stainless steel, powder-coated steel, or several *Designer* colors.

*NOTE: Narrow design strip heaters are not available with lights, sneeze guards, or as dual units.*

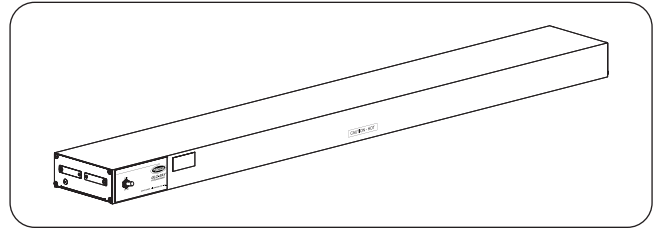

Figure 1. GRA-48 Model

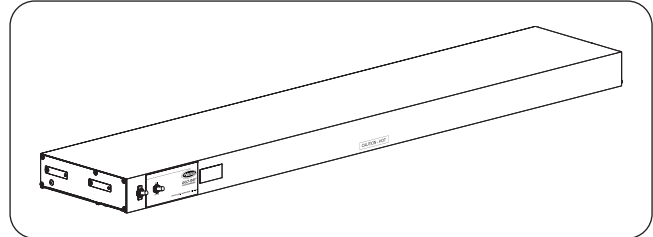

Figure 2. GRAHL-48 Model

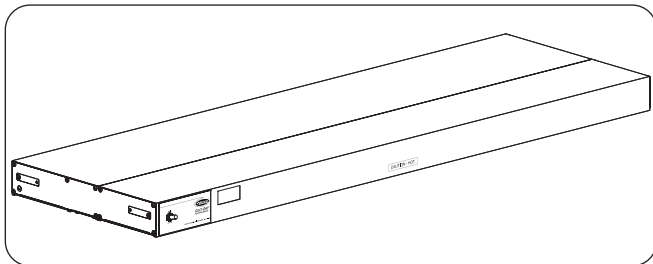

Figure 3. GRAL-48D Model

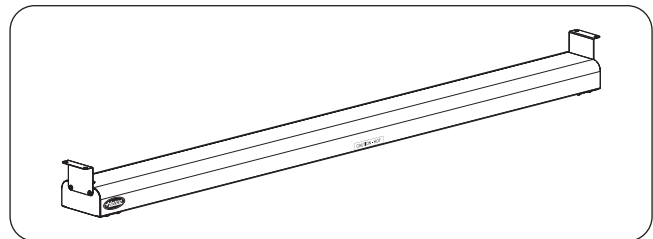

Figure 4. GRN-48 Model

# MODEL DESIGNATION

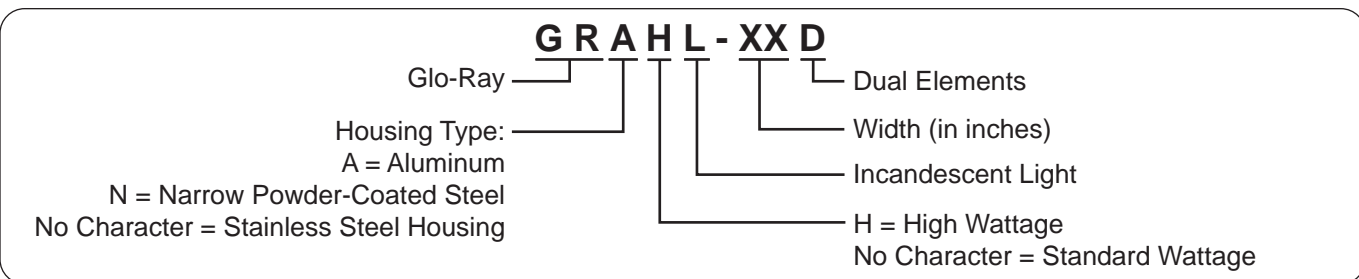

Figure 5. Model Designation

### Plug Configurations

An attached 1829 mm (6') cord and plug is available as a factory-installed option for certain units. These units must be 120 volt (V) models with built-in controls that are 1829 mm (72") or less and mounted with a standard chain kit, C-leg stand, or T-leg stand.

*NOTE: A cord and plug set is not available for units with lights.*



**ELECTRIC SHOCK HAZARD: Plug unit into a properly grounded electrical receptacle of the correct voltage, size, and plug configuration. If plug and receptacle do not match, contact a qualified electrician to determine and install proper voltage and size electrical receptacle.**

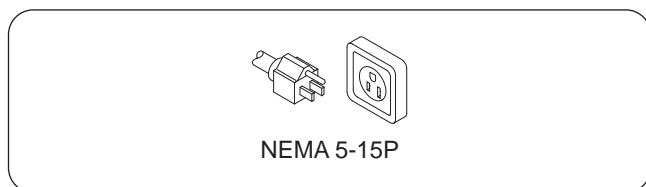

Figure 6. Plug Configurations

*NOTE: Receptacle not supplied by Hatco.*

### Electrical Rating Chart — GR Models

Model	Voltage	Watts	Amps	Shipping Weight
GR-18	120	250	2.1	3 kg (7 lbs.)
	208	250	1.2	3 kg (7 lbs.)
	240	250	1.0	3 kg (7 lbs.)
	100	250	2.5	3 kg (7 lbs.)
	200	250	1.3	3 kg (7 lbs.)
	220♦	250	1.1	3 kg (7 lbs.)
	240♦	250	1.0	3 kg (7 lbs.)
GR-24	120	350	2.9	3 kg (7 lbs.)
	208	350	1.7	3 kg (7 lbs.)
	240	350	1.5	3 kg (7 lbs.)
	100	350	3.5	3 kg (7 lbs.)
	200	350	1.8	3 kg (7 lbs.)
	220♦	350	1.6	3 kg (7 lbs.)
	240♦	350	1.5	3 kg (7 lbs.)
GR-36	120	575	4.8	5 kg (10 lbs.)
	208	575	2.8	5 kg (10 lbs.)
	240	575	2.4	5 kg (10 lbs.)
	100	575	5.8	5 kg (10 lbs.)
	200	575	2.9	5 kg (10 lbs.)
	220♦	575	2.6	5 kg (10 lbs.)
	240♦	575	2.4	5 kg (10 lbs.)
GR-48	120	800	6.7	5 kg (12 lbs.)
	208	800	3.8	5 kg (12 lbs.)
	240	800	3.3	5 kg (12 lbs.)
	100	800	8.0	5 kg (12 lbs.)
	200	800	4.0	5 kg (12 lbs.)
	220♦	800	3.6	5 kg (12 lbs.)
	240♦	800	3.3	5 kg (12 lbs.)
GR-60	120	1050	8.8	7 kg (15 lbs.)
	208	1050	5.0	7 kg (15 lbs.)
	240	1050	4.4	7 kg (15 lbs.)
	100	1050	10.5	7 kg (15 lbs.)
	200	1050	5.3	7 kg (15 lbs.)
	220♦	1050	4.8	7 kg (15 lbs.)
	240♦	1050	4.4	7 kg (15 lbs.)
GR-72	120	1275	10.6	9 kg (19 lbs.)
	208	1275	6.1	9 kg (19 lbs.)
	240	1275	5.3	9 kg (19 lbs.)
	100	1275	12.8	9 kg (19 lbs.)
	200	1275	6.4	9 kg (19 lbs.)
	220♦	1275	5.8	9 kg (19 lbs.)
	240♦	1275	5.3	9 kg (19 lbs.)
GR-96	120	1725	14.4	11 kg (24 lbs.)
	208	1725	8.3	11 kg (24 lbs.)
	240	1725	7.2	11 kg (24 lbs.)
	100	1725	17.3	11 kg (24 lbs.)
	200	1725	8.6	11 kg (24 lbs.)
	220♦	1725	7.8	11 kg (24 lbs.)
	240♦	1725	7.2	11 kg (24 lbs.)

The shaded areas contain electrical information for **International models only.**

♦ CE approved units for 220–230 V utilize a 220 V heating system; 230–240 V CE units utilize a 240 V heating system.

## Electrical Rating Chart — GRH Models

Model	Voltage	Watts	Amps	Shipping Weight
GRH-18	120	350	2.9	3 kg (7 lbs.)
	208	350	1.7	3 kg (7 lbs.)
	240	350	1.5	3 kg (7 lbs.)
	100	350	3.5	3 kg (7 lbs.)
	200	350	1.8	3 kg (7 lbs.)
	220♦	350	1.6	3 kg (7 lbs.)
	240♦	350	1.5	3 kg (7 lbs.)
GRH-24	120	500	4.2	3 kg (7 lbs.)
	208	500	2.4	3 kg (7 lbs.)
	240	500	2.1	3 kg (7 lbs.)
	100	500	5.0	3 kg (7 lbs.)
	200	500	2.5	3 kg (7 lbs.)
	220♦	500	2.3	3 kg (7 lbs.)
	240♦	500	2.1	3 kg (7 lbs.)
GRH-36	120	800	6.7	5 kg (10 lbs.)
	208	800	3.8	5 kg (10 lbs.)
	240	800	3.3	5 kg (10 lbs.)
	100	800	8.0	5 kg (10 lbs.)
	200	800	4.0	5 kg (10 lbs.)
	220♦	800	3.6	5 kg (10 lbs.)
	240♦	800	3.3	5 kg (10 lbs.)
GRH-48	120	1100	9.2	5 kg (12 lbs.)
	208	1100	5.3	5 kg (12 lbs.)
	240	1100	4.6	5 kg (12 lbs.)
	100	1100	11.0	5 kg (12 lbs.)
	200	1100	5.5	5 kg (12 lbs.)
	220♦	1100	5.0	5 kg (12 lbs.)
	240♦	1100	4.6	5 kg (12 lbs.)
GRH-60	120	1400	11.7	7 kg (15 lbs.)
	208	1400	6.7	7 kg (15 lbs.)
	240	1400	5.8	7 kg (15 lbs.)
	100	1400	14.0	7 kg (15 lbs.)
	200	1400	7.0	7 kg (15 lbs.)
	220♦	1400	6.4	7 kg (15 lbs.)
	240♦	1400	5.8	7 kg (15 lbs.)
GRH-72	120	1725	14.4	9 kg (19 lbs.)
	208	1725	8.3	9 kg (19 lbs.)
	240	1725	7.2	9 kg (19 lbs.)
	100	1725	17.3	9 kg (19 lbs.)
	200	1725	8.6	9 kg (19 lbs.)
	220♦	1725	7.8	9 kg (19 lbs.)
	240♦	1725	7.2	9 kg (19 lbs.)
GRH-96*	208	2400	11.5	11 kg (24 lbs.)
	240	2400	10.0	11 kg (24 lbs.)
	200	2400	12.0	11 kg (24 lbs.)
	220♦	2400	10.9	11 kg (24 lbs.)
	240♦	2400	10.0	11 kg (24 lbs.)

## Electrical Rating Chart — GRHL Models

Model	Voltage	Watts	Amps	Shipping Weight
GRHL-18	120	470	3.9	5 kg (10 lbs.)
	220	470	2.1	5 kg (10 lbs.)
	240	470	2.0	5 kg (10 lbs.)
GRHL-24	120	620	5.2	5 kg (10 lbs.)
	220	620	2.8	5 kg (10 lbs.)
	240	620	2.6	5 kg (10 lbs.)
GRHL-36	120	980	8.2	6 kg (14 lbs.)
	220	980	4.5	6 kg (14 lbs.)
	240	980	4.1	6 kg (14 lbs.)
GRHL-48	120	1340	11.2	8 kg (18 lbs.)
	220	1340	6.1	8 kg (18 lbs.)
	240	1340	5.6	8 kg (18 lbs.)
GRHL-60	120	1700	14.2	10 kg (22 lbs.)
	220	1700	7.7	10 kg (22 lbs.)
	240	1700	7.1	10 kg (22 lbs.)
GRHL-72	120	2085	17.4	12 kg (26 lbs.)
	220	2085	9.5	12 kg (26 lbs.)
	240	2085	8.7	12 kg (26 lbs.)

The shaded areas contain electrical information for **International models only**.

\* Not available in 100 V or 120 V.

♦ CE approved units for 220–230 V utilize a 220 V heating system; 230–240 V CE units utilize a 240 V heating system.

• 100 V and 120 V models with infinite switch require tandem (end-to-end) elements, consult factory for applications.

■ 100 V and 120 V models may require additional switches, consult factory for applications.

† Glo-Ray models 108"–144" and 120 V models of GRA-84 and GRA-96 contain tandem (end-to-end) elements that may be individually controlled.

**Electrical Rating Chart — GRA Models**

Model	Voltage	Watts	Amps	Shipping Weight
GRA-18	120	250	2.1	3 kg (6 lbs.)
	208	250	1.2	3 kg (6 lbs.)
	240	250	1.0	3 kg (6 lbs.)
	100	250	2.5	3 kg (6 lbs.)
	200	250	1.3	3 kg (6 lbs.)
	220♦	250	1.1	3 kg (6 lbs.)
	240♦	250	1.0	3 kg (6 lbs.)
GRA-24	120	350	2.9	3 kg (7 lbs.)
	208	350	1.7	3 kg (7 lbs.)
	240	350	1.5	3 kg (7 lbs.)
	100	350	3.5	3 kg (7 lbs.)
	200	350	1.8	3 kg (7 lbs.)
	220♦	350	1.6	3 kg (7 lbs.)
	240♦	350	1.5	3 kg (7 lbs.)
GRA-30	120	450	3.8	4 kg (8 lbs.)
	208	450	2.2	4 kg (8 lbs.)
	240	450	1.9	4 kg (8 lbs.)
	100	450	4.5	4 kg (8 lbs.)
	200	450	2.3	4 kg (8 lbs.)
	220♦	450	2.1	4 kg (8 lbs.)
	240♦	450	1.9	4 kg (8 lbs.)
GRA-36	120	575	4.8	4 kg (9 lbs.)
	208	575	2.8	4 kg (9 lbs.)
	240	575	2.4	4 kg (9 lbs.)
	100	575	5.8	4 kg (9 lbs.)
	200	575	2.9	4 kg (9 lbs.)
	220♦	575	2.6	4 kg (9 lbs.)
	240♦	575	2.4	4 kg (9 lbs.)
GRA-42	120	675	5.6	5 kg (10 lbs.)
	208	675	3.2	5 kg (10 lbs.)
	240	675	2.8	5 kg (10 lbs.)
	100	675	6.8	5 kg (10 lbs.)
	200	675	3.4	5 kg (10 lbs.)
	220♦	675	3.1	5 kg (10 lbs.)
	240♦	675	2.8	5 kg (10 lbs.)
GRA-48	120	800	6.7	5 kg (11 lbs.)
	208	800	3.8	5 kg (11 lbs.)
	240	800	3.3	5 kg (11 lbs.)
	100	800	8.0	5 kg (11 lbs.)
	200	800	4.0	5 kg (11 lbs.)
	220♦	800	3.6	5 kg (11 lbs.)
	240♦	800	3.3	5 kg (11 lbs.)
GRA-54	120	925	7.7	6 kg (13 lbs.)
	208	925	4.4	6 kg (13 lbs.)
	240	925	3.9	6 kg (13 lbs.)
	100	925	9.3	6 kg (13 lbs.)
	200	925	4.6	6 kg (13 lbs.)
	220♦	925	4.2	6 kg (13 lbs.)
	240♦	925	3.9	6 kg (13 lbs.)
GRA-60	120	1050	8.8	6 kg (14 lbs.)
	208	1050	5.0	6 kg (14 lbs.)
	240	1050	4.4	6 kg (14 lbs.)
	100	1050	10.5	6 kg (14 lbs.)
	200	1050	5.3	6 kg (14 lbs.)
	220♦	1050	4.8	6 kg (14 lbs.)
	240♦	1050	4.4	6 kg (14 lbs.)

Model	Voltage	Watts	Amps	Shipping Weight
GRA-66	120	1160	9.7	7 kg (16 lbs.)
	208	1160	5.6	7 kg (16 lbs.)
	240	1160	4.8	7 kg (16 lbs.)
	100	1160	11.6	7 kg (16 lbs.)
	200	1160	5.8	7 kg (16 lbs.)
	220♦	1160	5.3	7 kg (16 lbs.)
	240♦	1160	4.8	7 kg (16 lbs.)
GRA-72■	120	1275	10.6	8 kg (17 lbs.)
	208	1275	6.1	8 kg (17 lbs.)
	240	1275	5.3	8 kg (17 lbs.)
	100	1275	12.8	8 kg (17 lbs.)
	200	1275	6.4	8 kg (17 lbs.)
	220♦	1275	5.8	8 kg (17 lbs.)
	240♦	1275	5.3	8 kg (17 lbs.)
GRA-84•■	120	1500	12.5	9 kg (19 lbs.)
	208	1500	7.2	9 kg (19 lbs.)
	240	1500	6.3	9 kg (19 lbs.)
	100	1500	15.0	9 kg (19 lbs.)
	200	1500	7.5	9 kg (19 lbs.)
	220♦	1500	6.8	9 kg (19 lbs.)
	240♦	1500	6.3	9 kg (19 lbs.)
GRA-96•■	120	1725	14.4	10 kg (21 lbs.)
	208	1725	8.3	10 kg (21 lbs.)
	240	1725	7.2	10 kg (21 lbs.)
	100	1725	17.3	10 kg (21 lbs.)
	200	1725	8.6	10 kg (21 lbs.)
	220♦	1725	7.8	10 kg (21 lbs.)
	240♦	1725	7.2	10 kg (21 lbs.)
GRA-108†	120	1850	15.4	10 kg (23 lbs.)
	208	1850	8.9	10 kg (23 lbs.)
	240	1850	7.7	10 kg (23 lbs.)
	100	1850	18.5	10 kg (23 lbs.)
	200	1850	9.3	10 kg (23 lbs.)
	220	1850	8.4	10 kg (23 lbs.)
	240	1850	7.7	10 kg (23 lbs.)
GRA-120†	120	2100	17.5	12 kg (26 lbs.)
	208	2100	10.1	12 kg (26 lbs.)
	240	2100	8.8	12 kg (26 lbs.)
	100	2100	21.0	12 kg (26 lbs.)
	200	2100	10.5	12 kg (26 lbs.)
	220	2100	9.5	12 kg (26 lbs.)
	240	2100	8.8	12 kg (26 lbs.)
GRA-132†	120	2320	19.3	14 kg (30 lbs.)
	208	2320	11.2	14 kg (30 lbs.)
	240	2320	9.7	14 kg (30 lbs.)
	100	2320	23.2	14 kg (30 lbs.)
	200	2320	11.6	14 kg (30 lbs.)
	220	2320	10.5	14 kg (30 lbs.)
	240	2320	9.7	14 kg (30 lbs.)
GRA-144†	120	2550	21.3	15 kg (33 lbs.)
	208	2550	12.3	15 kg (33 lbs.)
	240	2550	10.6	15 kg (33 lbs.)
	100	2550	25.5	15 kg (33 lbs.)
	200	2550	12.8	15 kg (33 lbs.)
	220	2550	11.6	15 kg (33 lbs.)
	240	2550	10.6	15 kg (33 lbs.)

**Electrical Rating Chart — GRAH Models**

Model	Voltage	Watts	Amps	Shipping Weight
GRAH-18	120	350	2.9	3 kg (6 lbs.)
	208	350	1.7	3 kg (6 lbs.)
	240	350	1.5	3 kg (6 lbs.)
	100	350	3.5	3 kg (6 lbs.)
	200	350	1.8	3 kg (6 lbs.)
	220♦	350	1.6	3 kg (6 lbs.)
	240♦	350	1.5	3 kg (6 lbs.)
GRAH-24	120	500	4.2	3 kg (7 lbs.)
	208	500	2.4	3 kg (7 lbs.)
	240	500	2.1	3 kg (7 lbs.)
	100	500	5.0	3 kg (7 lbs.)
	200	500	2.5	3 kg (7 lbs.)
	220♦	500	2.3	3 kg (7 lbs.)
	240♦	500	2.1	3 kg (7 lbs.)
GRAH-30	120	660	5.5	4 kg (8 lbs.)
	208	660	3.2	4 kg (8 lbs.)
	240	660	2.8	4 kg (8 lbs.)
	100	660	6.6	4 kg (8 lbs.)
	200	660	3.3	4 kg (8 lbs.)
	220♦	660	33.0	4 kg (8 lbs.)
	240♦	660	2.8	4 kg (8 lbs.)
GRAH-36	120	800	6.7	4 kg (9 lbs.)
	208	800	3.8	4 kg (9 lbs.)
	240	800	3.3	4 kg (9 lbs.)
	100	800	8.0	4 kg (9 lbs.)
	200	800	4.0	4 kg (9 lbs.)
	220♦	800	3.6	4 kg (9 lbs.)
	240♦	800	3.3	4 kg (9 lbs.)
GRAH-42	120	950	7.9	5 kg (10 lbs.)
	208	950	4.6	5 kg (10 lbs.)
	240	950	4.0	5 kg (10 lbs.)
	100	950	9.5	5 kg (10 lbs.)
	200	950	4.8	5 kg (10 lbs.)
	220♦	950	4.3	5 kg (10 lbs.)
	240♦	950	4.0	5 kg (10 lbs.)
GRAH-48	120	1100	9.2	5 kg (11 lbs.)
	208	1100	5.3	5 kg (11 lbs.)
	240	1100	4.6	5 kg (11 lbs.)
	100	1100	11.0	5 kg (11 lbs.)
	200	1100	5.5	5 kg (11 lbs.)
	220♦	1100	5.0	5 kg (11 lbs.)
	240♦	1100	4.6	5 kg (11 lbs.)
GRAH-54	120	1250	10.4	6 kg (13 lbs.)
	208	1250	6.0	6 kg (13 lbs.)
	240	1250	5.2	6 kg (13 lbs.)
	100	1250	12.5	6 kg (13 lbs.)
	200	1250	6.3	6 kg (13 lbs.)
	220♦	1250	5.7	6 kg (13 lbs.)
	240♦	1250	5.2	6 kg (13 lbs.)
GRAH-60	120	1400	11.7	6 kg (14 lbs.)
	208	1400	6.7	6 kg (14 lbs.)
	240	1400	5.8	6 kg (14 lbs.)
	100	1400	14.0	6 kg (14 lbs.)
	200	1400	7.0	6 kg (14 lbs.)
	220♦	1400	6.4	6 kg (14 lbs.)
	240♦	1400	5.8	6 kg (14 lbs.)

Model	Voltage	Watts	Amps	Shipping Weight
GRAH-66	120	1560	13.0	7 kg (16 lbs.)
	208	1560	7.5	7 kg (16 lbs.)
	240	1560	6.5	7 kg (16 lbs.)
	100	1560	15.6	7 kg (16 lbs.)
	200	1560	7.8	7 kg (16 lbs.)
	220♦	1560	7.1	7 kg (16 lbs.)
	240♦	1560	6.5	7 kg (16 lbs.)
GRAH-72	120	1725	14.4	8 kg (17 lbs.)
	208	1725	8.3	8 kg (17 lbs.)
	240	1725	7.2	8 kg (17 lbs.)
	100	1725	17.3	8 kg (17 lbs.)
	200	1725	8.6	8 kg (17 lbs.)
	220♦	1725	7.8	8 kg (17 lbs.)
	240♦	1725	7.2	8 kg (17 lbs.)
GRAH-84■	120	2050	17.1	9 kg (19 lbs.)
	208	2050	9.9	9 kg (19 lbs.)
	240	2050	8.5	9 kg (19 lbs.)
	100	2050	20.5	9 kg (19 lbs.)
	200	2050	10.3	9 kg (19 lbs.)
	220♦	2050	9.3	9 kg (19 lbs.)
	240♦	2050	8.5	9 kg (19 lbs.)
GRAH-96■	120	2400	20.0	10 kg (21 lbs.)
	208	2400	11.5	10 kg (21 lbs.)
	240	2400	10.0	10 kg (21 lbs.)
	100	2400	24.0	10 kg (21 lbs.)
	200	2400	12.0	10 kg (21 lbs.)
	220♦	2400	10.9	10 kg (21 lbs.)
	240♦	2400	10.0	10 kg (21 lbs.)
GRAH-108†	120	2500	20.8	10 kg (23 lbs.)
	208	2500	12.0	10 kg (23 lbs.)
	240	2500	10.4	10 kg (23 lbs.)
	100	2500	25.0	10 kg (23 lbs.)
	200	2500	12.5	10 kg (23 lbs.)
	220	2500	11.4	10 kg (23 lbs.)
	240	2500	10.4	10 kg (23 lbs.)
GRAH-120†	120	2800	22.5	12 kg (26 lbs.)
	208	2800	13.5	12 kg (26 lbs.)
	240	2800	11.7	12 kg (26 lbs.)
	100	2800	28.0	12 kg (26 lbs.)
	200	2800	14.0	12 kg (26 lbs.)
	220	2800	12.7	12 kg (26 lbs.)
	240	2800	11.7	12 kg (26 lbs.)
GRAH-132†	120	3120	26.0	14 kg (30 lbs.)
	208	3120	15.0	14 kg (30 lbs.)
	240	3120	13.0	14 kg (30 lbs.)
	100	3120	31.2	14 kg (30 lbs.)
	200	3120	15.6	14 kg (30 lbs.)
	220	3120	14.2	14 kg (30 lbs.)
	240	3120	13.0	14 kg (30 lbs.)
GRAH-144†	120	3450	28.8	15 kg (33 lbs.)
	208	3450	16.6	15 kg (33 lbs.)
	240	3450	14.4	15 kg (33 lbs.)
	100	3450	34.5	15 kg (33 lbs.)
	200	3450	17.3	15 kg (33 lbs.)
	220	3450	15.7	15 kg (33 lbs.)
	240	3450	14.4	15 kg (33 lbs.)

The shaded areas contain electrical information for **International models only**.

♦ CE approved units for 220–230 V utilize a 220 V heating system; 230–240 V CE units utilize a 240 V heating system.

• 100 V and 120 V models with infinite switch require tandem (end-to-end) elements, consult factory for applications.

■ 100 V and 120 V models may require additional switches, consult factory for applications.

† Glo-Ray models 108"–144" and 120 V models of GRA-84 and GRA-96 contain tandem (end-to-end) elements that may be individually controlled.





## Electrical Rating Chart — GRAL Models

Model	Voltage	Watts	Amps	Shipping Weight
GRAL-18	120	370	3.1	4 kg (9 lbs.)
	120/208	370	2.2	4 kg (9 lbs.)
	120/240	370	2.0	4 kg (9 lbs.)
	100	370	3.7	4 kg (9 lbs.)
	100/200	370	2.5	4 kg (9 lbs.)
	220♦	370	1.7	4 kg (9 lbs.)
	240♦	370	1.5	4 kg (9 lbs.)
GRAL-24	120	470	3.9	5 kg (10 lbs.)
	120/208	470	2.7	5 kg (10 lbs.)
	120/240	470	2.5	5 kg (10 lbs.)
	100	470	4.7	5 kg (10 lbs.)
	100/200	470	3.0	5 kg (10 lbs.)
	220♦	470	2.1	5 kg (10 lbs.)
	240♦	470	2.0	5 kg (10 lbs.)
GRAL-30	120	570	4.8	5 kg (11 lbs.)
	120/208	570	3.2	5 kg (11 lbs.)
	120/240	570	2.9	5 kg (11 lbs.)
	100	570	5.7	5 kg (11 lbs.)
	100/200	570	3.5	5 kg (11 lbs.)
	220♦	570	2.6	5 kg (11 lbs.)
	240♦	570	2.4	5 kg (11 lbs.)
GRAL-36	120	755	6.3	6 kg (13 lbs.)
	120/208	755	4.3	6 kg (13 lbs.)
	120/240	755	3.9	6 kg (13 lbs.)
	100	755	7.6	6 kg (13 lbs.)
	100/200	755	4.7	6 kg (13 lbs.)
	220♦	755	3.4	6 kg (13 lbs.)
	240♦	755	3.1	6 kg (13 lbs.)
GRAL-42	120	855	7.1	7 kg (15 lbs.)
	120/208	855	4.7	7 kg (15 lbs.)
	120/240	855	4.3	7 kg (15 lbs.)
	100	855	8.6	7 kg (15 lbs.)
	100/200	855	5.2	7 kg (15 lbs.)
	220♦	855	3.9	7 kg (15 lbs.)
	240♦	855	3.6	7 kg (15 lbs.)
GRAL-48	120	1040	8.7	8 kg (17 lbs.)
	120/208	1040	5.8	8 kg (17 lbs.)
	120/240	1040	5.3	8 kg (17 lbs.)
	100	1040	10.4	8 kg (17 lbs.)
	100/200	1040	6.4	8 kg (17 lbs.)
	220♦	1040	4.7	8 kg (17 lbs.)
	240♦	1040	4.3	8 kg (17 lbs.)
GRAL-54	120	1165	9.7	9 kg (19 lbs.)
	120/208	1165	6.4	9 kg (19 lbs.)
	120/240	1165	5.9	9 kg (19 lbs.)
	100	1165	11.7	9 kg (19 lbs.)
	100/200	1165	7.0	9 kg (19 lbs.)
	220♦	1165	5.3	9 kg (19 lbs.)
	240♦	1165	4.9	9 kg (19 lbs.)
GRAL-60	120	1350	11.3	10 kg (21 lbs.)
	120/208	1350	7.5	10 kg (21 lbs.)
	120/240	1350	6.9	10 kg (21 lbs.)
	100	1350	13.5	10 kg (21 lbs.)
	100/200	1350	8.3	10 kg (21 lbs.)
	220♦	1350	6.1	10 kg (21 lbs.)
	240♦	1350	5.6	10 kg (21 lbs.)

Model	Voltage	Watts	Amps	Shipping Weight
GRAL-66	120	1460	12.2	10 kg (22 lbs.)
	120/208	1460	8.1	10 kg (22 lbs.)
	120/240	1460	7.3	10 kg (22 lbs.)
	100	1460	14.6	10 kg (22 lbs.)
	100/200	1460	8.8	10 kg (22 lbs.)
	220♦	1460	6.6	10 kg (22 lbs.)
	240♦	1460	6.1	10 kg (22 lbs.)
GRAL-72	120	1635	13.6	11 kg (24 lbs.)
	120/208	1635	9.1	11 kg (24 lbs.)
	120/240	1635	8.3	11 kg (24 lbs.)
	100	1635	16.4	11 kg (24 lbs.)
	100/200	1635	10.0	11 kg (24 lbs.)
	220♦	1635	7.4	11 kg (24 lbs.)
	240♦	1635	6.8	11 kg (24 lbs.)
GRAL-84♦■	120	1920	16.0	13 kg (28 lbs.)
	120/208	1920	10.7	13 kg (28 lbs.)
	120/240	1920	9.8	13 kg (28 lbs.)
	100	1920	19.2	13 kg (28 lbs.)
	100/200	1920	11.7	13 kg (28 lbs.)
	220♦	1920	8.7	13 kg (28 lbs.)
	240♦	1920	8.0	13 kg (28 lbs.)
GRAL-96♦■	120	2205	18.4	15 kg (32 lbs.)
	120/208	2205	12.3	15 kg (32 lbs.)
	120/240	2205	11.2	15 kg (32 lbs.)
	100	2205	22.1	15 kg (32 lbs.)
	100/200	2205	13.4	15 kg (32 lbs.)
	220♦	2205	10.0	15 kg (32 lbs.)
	240♦	2205	9.2	15 kg (32 lbs.)
GRAL-108†	120	2390	19.9	16 kg (36 lbs.)
	208	2390	13.4	16 kg (36 lbs.)
	240	2390	12.2	16 kg (36 lbs.)
	100	2390	23.9	16 kg (36 lbs.)
	200	2390	14.7	16 kg (36 lbs.)
	220	2390	10.9	16 kg (36 lbs.)
	240	2390	10.0	16 kg (36 lbs.)
GRAL-120†	120	2700	22.5	18 kg (40 lbs.)
	120/208	2700	15.1	18 kg (40 lbs.)
	120/240	2700	13.8	18 kg (40 lbs.)
	100	2700	27.0	18 kg (40 lbs.)
	100/200	2700	16.5	18 kg (40 lbs.)
	220	2700	12.3	18 kg (40 lbs.)
	240	2700	11.3	18 kg (40 lbs.)
GRAL-132†	120	2980	24.8	20 kg (44 lbs.)
	120/208	2980	16.7	20 kg (44 lbs.)
	120/240	2980	15.2	20 kg (44 lbs.)
	100	2980	29.8	20 kg (44 lbs.)
	100/200	2980	18.2	20 kg (44 lbs.)
	220	2980	13.5	20 kg (44 lbs.)
	240	2980	12.4	20 kg (44 lbs.)
GRAL-144†	120	3270	27.3	22 kg (48 lbs.)
	120/208	3270	18.3	22 kg (48 lbs.)
	120/240	3270	16.6	22 kg (48 lbs.)
	100	3270	32.7	22 kg (48 lbs.)
	100/200	3270	20.0	22 kg (48 lbs.)
	220	3270	14.9	22 kg (48 lbs.)
	240	3270	13.6	22 kg (48 lbs.)

**NOTE:** GRAL and GRAHL models that have multiple voltages listed, such as 120/208, 120/240 or 100/200, have multiple circuits. For example, a 120/208 V unit utilizes 120 V for the light circuit and 208 V for the heat circuit(s). Consult the electrical diagram supplied with the unit for specific information.



**Strip heaters equipped with incandescent lights that require a circuit breaker larger than 20 amps for the heat element must have a separate circuit breaker for the incandescent lights that is 20 amps or less.**

**Electrical Rating Chart — GRAHL Models**

Model	Voltage	Watts	Amps	Shipping Weight
GRAHL-18	120	470	3.9	4 kg (9 lbs.)
	120/208	470	2.7	4 kg (9 lbs.)
	120/240	470	2.5	4 kg (9 lbs.)
	100	470	4.7	4 kg (9 lbs.)
	100/200	470	3.0	4 kg (9 lbs.)
	220♦	470	2.1	4 kg (9 lbs.)
	240♦	470	2.0	4 kg (9 lbs.)
GRAHL-24	120	620	5.2	5 kg (10 lbs.)
	120/208	620	3.4	5 kg (10 lbs.)
	120/240	620	3.1	5 kg (10 lbs.)
	100	620	6.2	5 kg (10 lbs.)
	100/200	620	3.7	5 kg (10 lbs.)
	220♦	620	2.8	5 kg (10 lbs.)
	240♦	620	2.6	5 kg (10 lbs.)
GRAHL-30	120	780	6.5	5 kg (11 lbs.)
	120/208	780	4.2	5 kg (11 lbs.)
	120/240	780	3.8	5 kg (11 lbs.)
	100	780	7.8	5 kg (11 lbs.)
	100/200	780	4.5	5 kg (11 lbs.)
	220♦	780	3.5	5 kg (11 lbs.)
	240♦	780	3.3	5 kg (11 lbs.)
GRAHL-36	120	980	8.2	6 kg (13 lbs.)
	120/208	980	5.3	6 kg (13 lbs.)
	120/240	980	4.8	6 kg (13 lbs.)
	100	980	9.8	6 kg (13 lbs.)
	100/200	980	5.8	6 kg (13 lbs.)
	220♦	980	4.5	6 kg (13 lbs.)
	240♦	980	4.1	6 kg (13 lbs.)
GRAHL-42	120	1130	9.4	7 kg (15 lbs.)
	120/208	1130	6.1	7 kg (15 lbs.)
	120/240	1130	5.5	7 kg (15 lbs.)
	100	1130	11.3	7 kg (15 lbs.)
	100/200	1130	6.6	7 kg (15 lbs.)
	220♦	1130	5.1	7 kg (15 lbs.)
	240♦	1130	4.7	7 kg (15 lbs.)
GRAHL-48	120	1340	11.2	8 kg (17 lbs.)
	120/208	1340	7.3	8 kg (17 lbs.)
	120/240	1340	6.6	8 kg (17 lbs.)
	100	1340	13.4	8 kg (17 lbs.)
	100/200	1340	7.9	8 kg (17 lbs.)
	220♦	1340	6.1	8 kg (17 lbs.)
	240♦	1340	5.6	8 kg (17 lbs.)
GRAHL-54	120	1490	12.4	9 kg (19 lbs.)
	120/208	1490	8.0	9 kg (19 lbs.)
	120/240	1490	7.2	9 kg (19 lbs.)
	100	1490	14.9	9 kg (19 lbs.)
	100/200	1490	8.7	9 kg (19 lbs.)
	220♦	1490	6.8	9 kg (19 lbs.)
	240♦	1490	6.2	9 kg (19 lbs.)
GRAHL-60	120	1700	14.2	10 kg (21 lbs.)
	120/208	1700	9.2	10 kg (21 lbs.)
	120/240	1700	8.3	10 kg (21 lbs.)
	100	1700	17.0	10 kg (21 lbs.)
	100/200	1700	10.0	10 kg (21 lbs.)
	220♦	1700	7.7	10 kg (21 lbs.)
	240♦	1700	7.1	10 kg (21 lbs.)

Model	Voltage	Watts	Amps	Shipping Weight
GRAHL-66■	120	1860	15.5	10 kg (22 lbs.)
	120/208	1860	10.0	10 kg (22 lbs.)
	120/240	1860	9.0	10 kg (22 lbs.)
	100	1860	18.6	10 kg (22 lbs.)
	100/200	1860	10.8	10 kg (22 lbs.)
	220♦	1860	8.5	10 kg (22 lbs.)
	240♦	1860	7.8	10 kg (22 lbs.)
GRAHL-72■	120	2085	17.4	11 kg (24 lbs.)
	120/208	2085	11.3	11 kg (24 lbs.)
	120/240	2085	10.2	11 kg (24 lbs.)
	100	2085	20.9	11 kg (24 lbs.)
	100/200	2085	12.2	11 kg (24 lbs.)
	220♦	2085	9.5	11 kg (24 lbs.)
	240♦	2085	8.7	11 kg (24 lbs.)
GRAHL-84■	120	2470	20.6	13 kg (28 lbs.)
	120/208	2470	13.4	13 kg (28 lbs.)
	120/240	2470	12.0	13 kg (28 lbs.)
	100	2470	24.7	13 kg (28 lbs.)
	100/200	2470	14.5	13 kg (28 lbs.)
	220♦	2470	11.2	13 kg (28 lbs.)
	240♦	2470	10.3	13 kg (28 lbs.)
GRAHL-96■	120	2880	24.0	15 kg (32 lbs.)
	120/208	2880	15.5	15 kg (32 lbs.)
	120/240	2880	14.0	15 kg (32 lbs.)
	100	2880	28.8	15 kg (32 lbs.)
	100/200	2880	16.8	15 kg (32 lbs.)
	220♦	2880	13.1	15 kg (32 lbs.)
	240♦	2880	12.0	15 kg (32 lbs.)
GRAHL-108†	120	3040	25.3	16 kg (36 lbs.)
	208	3040	16.5	16 kg (36 lbs.)
	240	3040	14.9	16 kg (36 lbs.)
	100	3040	30.4	16 kg (36 lbs.)
	200	3040	17.9	16 kg (36 lbs.)
	220	3040	13.8	16 kg (36 lbs.)
	240	3040	12.7	16 kg (36 lbs.)
GRAHL-120†	120	3400	28.3	18 kg (40 lbs.)
	120/208	3400	18.5	18 kg (40 lbs.)
	120/240	3400	16.7	18 kg (40 lbs.)
	100	3400	34.0	18 kg (40 lbs.)
	100/200	3400	20.0	18 kg (40 lbs.)
	220	3400	15.5	18 kg (40 lbs.)
	240	3400	14.2	18 kg (40 lbs.)
GRAHL-132†	120	3780	31.5	20 kg (44 lbs.)
	120/208	3780	20.5	20 kg (44 lbs.)
	120/240	3780	18.5	20 kg (44 lbs.)
	100	3780	37.8	20 kg (44 lbs.)
	100/200	3780	22.2	20 kg (44 lbs.)
	220	3780	17.2	20 kg (44 lbs.)
	240	3780	15.8	20 kg (44 lbs.)
GRAHL-144†	120	4170	34.8	22 kg (48 lbs.)
	120/208	4170	22.6	22 kg (48 lbs.)
	120/240	4170	20.4	22 kg (48 lbs.)
	100	4170	41.7	22 kg (48 lbs.)
	100/200	4170	24.5	22 kg (48 lbs.)
	220	4170	19.0	22 kg (48 lbs.)
	240	4170	17.4	22 kg (48 lbs.)

**NOTE:** GRAL and GRAHL models that have multiple voltages listed, such as 120/208, 120/240 or 100/200, have multiple circuits. For example, a 120/208 V unit utilizes 120 V for the light circuit and 208 V for the heat circuit(s). Consult the electrical diagram supplied with the unit for specific information.



**Strip heaters equipped with incandescent lights that require a circuit breaker larger than 20 amps for the heat element must have a separate circuit breaker for the incandescent lights that is 20 amps or less.**

## Electrical Rating Chart — GRA-XXD Models

Model	Voltage	Watts	Amps	Shipping Weight
GRA-18D	120	500	4.2	6 kg (14 lbs.)
	208	500	2.4	6 kg (14 lbs.)
	240	500	2.1	6 kg (14 lbs.)
	100	500	5.0	6 kg (14 lbs.)
	200	500	2.5	6 kg (14 lbs.)
	220♦	500	2.3	6 kg (14 lbs.)
	240♦	500	2.1	6 kg (14 lbs.)
GRA-24D	120	700	5.8	7 kg (16 lbs.)
	208	700	3.4	7 kg (16 lbs.)
	240	700	2.9	7 kg (16 lbs.)
	100	700	7.0	7 kg (16 lbs.)
	200	700	3.5	7 kg (16 lbs.)
	220♦	700	3.2	7 kg (16 lbs.)
	240♦	700	2.9	7 kg (16 lbs.)
GRA-30D	120	900	7.5	8 kg (18 lbs.)
	208	900	4.3	8 kg (18 lbs.)
	240	900	3.8	8 kg (18 lbs.)
	100	900	9.0	8 kg (18 lbs.)
	200	900	4.5	8 kg (18 lbs.)
	220♦	900	4.1	8 kg (18 lbs.)
	240♦	900	3.8	8 kg (18 lbs.)
GRA-36D■	120	1150	9.6	10 kg (21 lbs.)
	208	1150	5.5	10 kg (21 lbs.)
	240	1150	4.8	10 kg (21 lbs.)
	100	1150	11.5	10 kg (21 lbs.)
	200	1150	5.8	10 kg (21 lbs.)
	220♦	1150	5.2	10 kg (21 lbs.)
	240♦	1150	4.8	10 kg (21 lbs.)
GRA-42D■	120	1350	11.3	11 kg (24 lbs.)
	208	1350	6.5	11 kg (24 lbs.)
	240	1350	5.6	11 kg (24 lbs.)
	100	1350	13.5	11 kg (24 lbs.)
	200	1350	6.8	11 kg (24 lbs.)
	220♦	1350	6.1	11 kg (24 lbs.)
	240♦	1350	5.6	11 kg (24 lbs.)
GRA-48D■	120	1600	13.3	12 kg (27 lbs.)
	208	1600	7.7	12 kg (27 lbs.)
	240	1600	6.7	12 kg (27 lbs.)
	100	1600	16.0	12 kg (27 lbs.)
	200	1600	8.0	12 kg (27 lbs.)
	220♦	1600	7.3	12 kg (27 lbs.)
	240♦	1600	6.7	12 kg (27 lbs.)
GRA-54D■	120	1850	15.4	14 kg (30 lbs.)
	208	1850	8.9	14 kg (30 lbs.)
	240	1850	7.7	14 kg (30 lbs.)
	100	1850	18.5	14 kg (30 lbs.)
	200	1850	9.3	14 kg (30 lbs.)
	220♦	1850	8.4	14 kg (30 lbs.)
	240♦	1850	7.7	14 kg (30 lbs.)
GRA-60D■	120	2100	17.5	15 kg (34 lbs.)
	208	2100	10.1	15 kg (34 lbs.)
	240	2100	8.8	15 kg (34 lbs.)
	100	2100	21.0	15 kg (34 lbs.)
	200	2100	10.5	15 kg (34 lbs.)
	220♦	2100	9.5	15 kg (34 lbs.)
	240♦	2100	8.8	15 kg (34 lbs.)

Model	Voltage	Watts	Amps	Shipping Weight
GRA-66D■	120	2320	19.3	17 kg (37 lbs.)
	208	2320	11.2	17 kg (37 lbs.)
	240	2320	9.7	17 kg (37 lbs.)
	100	2320	23.2	17 kg (37 lbs.)
	200	2320	11.6	17 kg (37 lbs.)
	220♦	2320	10.5	17 kg (37 lbs.)
	240♦	2320	9.7	17 kg (37 lbs.)
GRA-72D■	120	2550	21.3	19 kg (41 lbs.)
	208	2550	12.3	19 kg (41 lbs.)
	240	2550	10.6	19 kg (41 lbs.)
	100	2550	25.5	19 kg (41 lbs.)
	200	2550	12.8	19 kg (41 lbs.)
	220♦	2550	11.6	19 kg (41 lbs.)
	240♦	2550	10.6	19 kg (41 lbs.)
GRA-84D†■	120	3000	25.0	20 kg (44 lbs.)
	208	3000	14.4	20 kg (44 lbs.)
	240	3000	12.5	20 kg (44 lbs.)
	100	3000	30.0	20 kg (44 lbs.)
	200	3000	15.0	20 kg (44 lbs.)
	220♦	3000	13.6	20 kg (44 lbs.)
	240♦	3000	12.5	20 kg (44 lbs.)
GRA-96D†■	120	3450	28.8	24 kg (52 lbs.)
	208	3450	16.6	24 kg (52 lbs.)
	240	3450	14.4	24 kg (52 lbs.)
	100	3450	34.5	24 kg (52 lbs.)
	200	3450	17.3	24 kg (52 lbs.)
	220♦	3450	15.7	24 kg (52 lbs.)
	240♦	3450	14.4	24 kg (52 lbs.)
GRA-108D†■	120	3700	30.8	27 kg (59 lbs.)
	208	3700	17.8	27 kg (59 lbs.)
	240	3700	15.4	27 kg (59 lbs.)
	100	3700	37.0	27 kg (59 lbs.)
	200	3700	18.5	27 kg (59 lbs.)
	220	3700	16.8	27 kg (59 lbs.)
	240	3700	15.4	27 kg (59 lbs.)
GRA-120D†	120	4200	35.0	30 kg (66 lbs.)
	208	4200	20.2	30 kg (66 lbs.)
	240	4200	17.5	30 kg (66 lbs.)
	100	4200	42.0	30 kg (66 lbs.)
	200	4200	21.0	30 kg (66 lbs.)
	220	4200	19.1	30 kg (66 lbs.)
	240	4200	17.5	30 kg (66 lbs.)
GRA-132D†	120	4640	38.7	33 kg (73 lbs.)
	208	4640	22.3	33 kg (73 lbs.)
	240	4640	19.3	33 kg (73 lbs.)
	100	4640	46.4	33 kg (73 lbs.)
	200	4640	23.2	33 kg (73 lbs.)
	220	4640	21.1	33 kg (73 lbs.)
	240	4640	19.3	33 kg (73 lbs.)
GRA-144D†	120	5100	42.5	36 kg (80 lbs.)
	208	5100	24.5	36 kg (80 lbs.)
	240	5100	21.3	36 kg (80 lbs.)
	100	5100	51.0	36 kg (80 lbs.)
	200	5100	25.5	36 kg (80 lbs.)
	220	5100	23.2	36 kg (80 lbs.)
	240	5100	21.3	36 kg (80 lbs.)

■ The shaded areas contain electrical information for **International models only**.

♦ CE approved units for 220–230 V utilize a 220 V heating system; 230–240 V CE units utilize a 240 V heating system.

• 100 V and 120 V models with infinite switch require tandem (end-to-end) elements, consult factory for applications.

■ 100 V and 120 V models may require additional switches, consult factory for applications.

† Glo-Ray models 108"–144" and 120 V models of GRA-84 and GRA-96 contain tandem (end-to-end) elements that may be individually controlled.

**Electrical Rating Chart — GRAH-XXD Models**

Model	Voltage	Watts	Amps	Shipping Weight
GRAH-18D	120	700	5.8	6 kg (14 lbs.)
	208	700	3.4	6 kg (14 lbs.)
	240	700	2.9	6 kg (14 lbs.)
	100	700	7.0	6 kg (14 lbs.)
	200	700	3.5	6 kg (14 lbs.)
	220♦	700	3.2	6 kg (14 lbs.)
	240♦	700	2.9	6 kg (14 lbs.)
GRAH-24D	120	1000	8.3	7 kg (16 lbs.)
	208	1000	4.8	7 kg (16 lbs.)
	240	1000	4.2	7 kg (16 lbs.)
	100	1000	10.0	7 kg (16 lbs.)
	200	1000	5.0	7 kg (16 lbs.)
	220♦	1000	4.5	7 kg (16 lbs.)
	240♦	1000	4.2	7 kg (16 lbs.)
GRAH-30D	120	1320	11.0	8 kg (18 lbs.)
	208	1320	6.3	8 kg (18 lbs.)
	240	1320	5.5	8 kg (18 lbs.)
	100	1320	13.2	8 kg (18 lbs.)
	200	1320	6.6	8 kg (18 lbs.)
	220♦	1320	6.0	8 kg (18 lbs.)
	240♦	1320	5.5	8 kg (18 lbs.)
GRAH-36D■	120	1600	13.3	10 kg (21 lbs.)
	208	1600	7.7	10 kg (21 lbs.)
	240	1600	6.7	10 kg (21 lbs.)
	100	1600	16.0	10 kg (21 lbs.)
	200	1600	8.0	10 kg (21 lbs.)
	220♦	1600	7.3	10 kg (21 lbs.)
	240♦	1600	6.7	10 kg (21 lbs.)
GRAH-42D■	120	1900	15.8	11 kg (24 lbs.)
	208	1900	9.1	11 kg (24 lbs.)
	240	1900	7.9	11 kg (24 lbs.)
	100	1900	19.0	11 kg (24 lbs.)
	200	1900	9.5	11 kg (24 lbs.)
	220♦	1900	8.6	11 kg (24 lbs.)
	240♦	1900	7.9	11 kg (24 lbs.)
GRAH-48D■	120	2200	18.3	12 kg (27 lbs.)
	208	2200	10.6	12 kg (27 lbs.)
	240	2200	9.2	12 kg (27 lbs.)
	100	2200	22.0	12 kg (27 lbs.)
	200	2200	11.0	12 kg (27 lbs.)
	220♦	2200	10.0	12 kg (27 lbs.)
	240♦	2200	9.2	12 kg (27 lbs.)
GRAH-54D■	120	2500	20.8	14 kg (30 lbs.)
	208	2500	12.0	14 kg (30 lbs.)
	240	2500	10.4	14 kg (30 lbs.)
	100	2500	25.0	14 kg (30 lbs.)
	200	2500	12.5	14 kg (30 lbs.)
	220♦	2500	11.4	14 kg (30 lbs.)
	240♦	2500	10.4	14 kg (30 lbs.)
GRAH-60D■	120	2800	23.3	15 kg (34 lbs.)
	208	2800	13.5	15 kg (34 lbs.)
	240	2800	11.7	15 kg (34 lbs.)
	100	2800	28.0	15 kg (34 lbs.)
	200	2800	14.0	15 kg (34 lbs.)
	220♦	2800	12.7	15 kg (34 lbs.)
	240♦	2800	11.7	15 kg (34 lbs.)

Model	Voltage	Watts	Amps	Shipping Weight
GRAH-66D■	120	3120	26.0	17 kg (37 lbs.)
	208	3120	15.0	17 kg (37 lbs.)
	240	3120	13.0	17 kg (37 lbs.)
	100	3120	31.2	17 kg (37 lbs.)
	200	3120	15.6	17 kg (37 lbs.)
	220♦	3120	14.2	17 kg (37 lbs.)
	240♦	3120	13.0	17 kg (37 lbs.)
GRAH-72D■	120	3450	28.8	19 kg (41 lbs.)
	208	3450	16.6	19 kg (41 lbs.)
	240	3450	14.4	19 kg (41 lbs.)
	100	3450	34.5	19 kg (41 lbs.)
	200	3450	17.3	19 kg (41 lbs.)
	220♦	3450	15.7	19 kg (41 lbs.)
	240♦	3450	14.4	19 kg (41 lbs.)
GRAH-84D†■	120	4100	34.2	20 kg (44 lbs.)
	208	4100	19.7	20 kg (44 lbs.)
	240	4100	17.1	20 kg (44 lbs.)
	100	4100	41.0	20 kg (44 lbs.)
	200	4100	20.5	20 kg (44 lbs.)
	220♦	4100	18.6	20 kg (44 lbs.)
	240♦	4100	17.1	20 kg (44 lbs.)
GRAH-96D†■	120	4800	40.0	24 kg (52 lbs.)
	208	4800	23.1	24 kg (52 lbs.)
	240	4800	20.0	24 kg (52 lbs.)
	100	4800	48.0	24 kg (52 lbs.)
	200	4800	24.0	24 kg (52 lbs.)
	220♦	4800	21.8	24 kg (52 lbs.)
	240♦	4800	20.0	24 kg (52 lbs.)
GRAH-108D†■	120	5000	41.7	27 kg (59 lbs.)
	208	5000	24.0	27 kg (59 lbs.)
	240	5000	20.8	27 kg (59 lbs.)
	100	5000	50.0	27 kg (59 lbs.)
	200	5000	25.0	27 kg (59 lbs.)
	220	5000	22.7	27 kg (59 lbs.)
	240	5000	20.8	27 kg (59 lbs.)
GRAH-120D†*	208	5600	26.9	30 kg (66 lbs.)
	240	5600	23.3	30 kg (66 lbs.)
	100	5600	---	30 kg (66 lbs.)
	200	5600	28.0	30 kg (66 lbs.)
	220	5600	25.5	30 kg (66 lbs.)
	240	5600	23.3	30 kg (66 lbs.)
	GRAH-132D†*	208	6240	30.0
240		6240	26.0	33 kg (73 lbs.)
100		6240	---	33 kg (73 lbs.)
200		6240	31.2	33 kg (73 lbs.)
220		6240	28.4	33 kg (73 lbs.)
240		6240	26.0	33 kg (73 lbs.)
GRAH-144D†*		208	6900	33.2
	240	6900	28.8	33 kg (73 lbs.)
	100	6900	---	36 kg (80 lbs.)
	200	6900	34.5	36 kg (80 lbs.)
	220	6900	31.4	36 kg (80 lbs.)
	240	6900	28.8	36 kg (80 lbs.)

\* Not available in 100 or 120 V.

♦ CE approved units for 220–230 V utilize a 220 V heating system; 230–240 V CE units utilize a 240 V heating system.

• 100 V and 120 V models with infinite switch require tandem (end-to-end) elements, consult factory for applications.

■ 100 V and 120 V models may require additional switches, consult factory for applications.

† Glo-Ray models 108”–144” and 120 V models of GRA-84 and GRA-96 contain tandem (end-to-end) elements that may be individually controlled.

Electrical Rating Chart — GRAL-XXD Models

Model	Voltage	Watts	Amps	Shipping Weight
GRAL-18D	120	620	5.2	6 kg (14 lbs.)
	120/208	620	3.4	6 kg (14 lbs.)
	120/240	620	3.1	6 kg (14 lbs.)
	100	620	6.2	6 kg (14 lbs.)
	100/200	620	3.7	6 kg (14 lbs.)
	220◆	620	2.8	6 kg (14 lbs.)
	240◆	620	2.6	6 kg (14 lbs.)
GRAL-24D	120	820	6.8	7 kg (16 lbs.)
	120/208	820	4.4	7 kg (16 lbs.)
	120/240	820	3.9	7 kg (16 lbs.)
	100	820	8.2	7 kg (16 lbs.)
	100/200	820	4.7	7 kg (16 lbs.)
	220◆	820	3.7	7 kg (16 lbs.)
	240◆	820	3.4	7 kg (16 lbs.)
GRAL-30D	120	1020	8.5	9 kg (19 lbs.)
	120/208	1020	5.3	9 kg (19 lbs.)
	120/240	1020	4.8	9 kg (19 lbs.)
	100	1020	10.2	9 kg (19 lbs.)
	100/200	1020	5.7	9 kg (19 lbs.)
	220◆	1020	4.6	9 kg (19 lbs.)
	240◆	1020	4.3	9 kg (19 lbs.)
GRAL-36D	120	1330	11.1	10 kg (22 lbs.)
	120/208	1330	7.0	10 kg (22 lbs.)
	120/240	1330	6.3	10 kg (22 lbs.)
	100	1330	13.3	10 kg (22 lbs.)
	100/200	1330	7.6	10 kg (22 lbs.)
	220◆	1330	6.0	10 kg (22 lbs.)
	240◆	1330	5.5	10 kg (22 lbs.)
GRAL-42D	120	1530	12.8	11 kg (25 lbs.)
	120/208	1530	8.0	11 kg (25 lbs.)
	120/240	1530	7.1	11 kg (25 lbs.)
	100	1530	15.3	11 kg (25 lbs.)
	100/200	1530	8.6	11 kg (25 lbs.)
	220◆	1530	7.0	11 kg (25 lbs.)
	240◆	1530	6.4	11 kg (25 lbs.)
GRAL-48D■	120	1840	15.3	13 kg (29 lbs.)
	120/208	1840	9.7	13 kg (29 lbs.)
	120/240	1840	8.7	13 kg (29 lbs.)
	100	1840	18.4	13 kg (29 lbs.)
	100/200	1840	10.4	13 kg (29 lbs.)
	220◆	1840	8.4	13 kg (29 lbs.)
	240◆	1840	7.7	13 kg (29 lbs.)
GRAL-54D■	120	2090	17.4	15 kg (33 lbs.)
	120/208	2090	10.9	15 kg (33 lbs.)
	120/240	2090	9.7	15 kg (33 lbs.)
	100	2090	20.9	15 kg (33 lbs.)
	100/200	2090	11.7	15 kg (33 lbs.)
	220◆	2090	9.5	15 kg (33 lbs.)
	240◆	2090	8.7	15 kg (33 lbs.)
GRAL-60D■	120	2400	20.0	17 kg (37 lbs.)
	120/208	2400	12.6	17 kg (37 lbs.)
	120/240	2400	11.3	17 kg (37 lbs.)
	100	2400	24.0	17 kg (37 lbs.)
	100/200	2400	13.5	17 kg (37 lbs.)
	220◆	2400	10.9	17 kg (37 lbs.)
	240◆	2400	10.0	17 kg (37 lbs.)

Model	Voltage	Watts	Amps	Shipping Weight
GRAL-66D■	120	2620	21.8	18 kg (40 lbs.)
	120/208	2620	13.7	18 kg (40 lbs.)
	120/240	2620	12.2	18 kg (40 lbs.)
	100	2620	26.2	18 kg (40 lbs.)
	100/200	2620	14.6	18 kg (40 lbs.)
	220◆	2620	11.9	18 kg (40 lbs.)
	240◆	2620	10.9	18 kg (40 lbs.)
GRAL-72D■	120	2910	24.3	19 kg (42 lbs.)
	120/208	2910	15.3	19 kg (42 lbs.)
	120/240	2910	13.6	19 kg (42 lbs.)
	100	2910	29.1	19 kg (42 lbs.)
	100/200	2910	16.4	19 kg (42 lbs.)
	220◆	2910	13.2	19 kg (42 lbs.)
	240◆	2910	12.1	19 kg (42 lbs.)
GRAL-84D◆■	120	3420	28.5	21 kg (47 lbs.)
	120/208	3420	17.9	21 kg (47 lbs.)
	120/240	3420	16.0	21 kg (47 lbs.)
	100	3420	34.2	21 kg (47 lbs.)
	100/200	3420	19.2	21 kg (47 lbs.)
	220◆	3420	15.5	21 kg (47 lbs.)
	240◆	3420	14.3	21 kg (47 lbs.)
GRAL-96D◆■	120	3930	32.8	25 kg (56 lbs.)
	120/208	3930	20.6	25 kg (56 lbs.)
	120/240	3930	18.4	25 kg (56 lbs.)
	100	3930	39.3	25 kg (56 lbs.)
	100/200	3930	22.1	25 kg (56 lbs.)
	220◆	3930	17.9	25 kg (56 lbs.)
	240◆	3930	16.4	25 kg (56 lbs.)
GRAL-108D†■	120	4240	35.3	29 kg (64 lbs.)
	120/208	4240	22.3	29 kg (64 lbs.)
	120/240	4240	19.9	29 kg (64 lbs.)
	100	4240	42.4	29 kg (64 lbs.)
	100/200	4240	23.9	29 kg (64 lbs.)
	220◆	4240	19.3	29 kg (64 lbs.)
	240◆	4240	17.7	29 kg (64 lbs.)
GRAL-120D†*	120/208	4800	25.2	33 kg (72 lbs.)
	120/240	4800	22.5	33 kg (72 lbs.)
	100	4800	---	33 kg (72 lbs.)
	100/200	4800	27.0	33 kg (72 lbs.)
	220◆	4800	21.8	33 kg (72 lbs.)
	240◆	4800	20.0	33 kg (72 lbs.)
	GRAL-132D†*■	120/208	5300	27.8
120/240		5300	24.8	36 kg (79 lbs.)
100		5300	---	36 kg (79 lbs.)
100/200		5300	29.8	36 kg (79 lbs.)
220◆		5300	24.1	36 kg (79 lbs.)
240◆		5300	22.1	36 kg (79 lbs.)
GRAL-144D†*		120/208	5820	30.5
	120/240	5820	27.3	39 kg (86 lbs.)
	100	5820	---	39 kg (86 lbs.)
	100/200	5820	32.7	39 kg (86 lbs.)
	220◆	5820	26.5	39 kg (86 lbs.)
	240◆	5820	24.3	39 kg (86 lbs.)

The shaded areas contain electrical information for **International models only**.

**NOTE:** GRAL and GRAHL models that have multiple voltages listed, such as 120/208, 120/240 or 100/200, have multiple circuits. For example, a 120/208 V unit utilizes 120 V for the light circuit and 208 V for the heat circuit(s). Consult the electrical diagram supplied with the unit for specific information.



Strip heaters equipped with incandescent lights that require a circuit breaker larger than 20 amps for the heat element must have a separate circuit breaker for the incandescent lights that is 20 amps or less.

## Electrical Rating Chart — GRAHL-XXD Models

Model	Voltage	Watts	Amps	Shipping Weight
GRAHL-18D	120	820	6.8	6 kg (14 lbs.)
	120/208	820	4.4	6 kg (14 lbs.)
	120/240	820	3.9	6 kg (14 lbs.)
	100	820	8.2	6 kg (14 lbs.)
	100/200	820	4.7	6 kg (14 lbs.)
	220♦	820	3.7	6 kg (14 lbs.)
	240♦	820	3.4	6 kg (14 lbs.)
GRAHL-24D	120	1120	9.3	7 kg (16 lbs.)
	120/208	1120	5.8	7 kg (16 lbs.)
	120/240	1120	5.2	7 kg (16 lbs.)
	100	1120	11.2	7 kg (16 lbs.)
	100/200	1120	6.2	7 kg (16 lbs.)
	220♦	1120	5.1	7 kg (16 lbs.)
	240♦	1120	4.7	7 kg (16 lbs.)
GRAHL-30D	120	1440	12.0	9 kg (19 lbs.)
	120/208	1440	7.3	9 kg (19 lbs.)
	120/240	1440	6.5	9 kg (19 lbs.)
	100	1440	14.4	9 kg (19 lbs.)
	100/200	1440	7.8	9 kg (19 lbs.)
	220♦	1440	6.5	9 kg (19 lbs.)
	240♦	1440	6.0	9 kg (19 lbs.)
GRAHL-36D■	120	1780	14.8	10 kg (22 lbs.)
	120/208	1780	9.2	10 kg (22 lbs.)
	120/240	1780	8.2	10 kg (22 lbs.)
	100	1780	17.8	10 kg (22 lbs.)
	100/200	1780	9.8	10 kg (22 lbs.)
	220♦	1780	8.1	10 kg (22 lbs.)
	240♦	1780	7.4	10 kg (22 lbs.)
GRAHL-42D■	120	2080	17.3	11 kg (25 lbs.)
	120/208	2080	10.6	11 kg (25 lbs.)
	120/240	2080	9.4	11 kg (25 lbs.)
	100	2080	20.8	11 kg (25 lbs.)
	100/200	2080	11.3	11 kg (25 lbs.)
	220♦	2080	9.5	11 kg (25 lbs.)
	240♦	2080	8.7	11 kg (25 lbs.)
GRAHL-48D■	120	2440	20.3	13 kg (29 lbs.)
	120/208	2440	12.6	13 kg (29 lbs.)
	120/240	2440	11.2	13 kg (29 lbs.)
	100	2440	24.4	13 kg (29 lbs.)
	100/200	2440	13.4	13 kg (29 lbs.)
	220♦	2440	11.1	13 kg (29 lbs.)
	240♦	2440	10.2	13 kg (29 lbs.)
GRAHL-54D■	120	2740	22.8	15 kg (33 lbs.)
	120/208	2740	14.0	15 kg (33 lbs.)
	120/240	2740	12.4	15 kg (33 lbs.)
	100	2740	27.4	15 kg (33 lbs.)
	100/200	2740	14.9	15 kg (33 lbs.)
	220♦	2740	12.5	15 kg (33 lbs.)
	240♦	2740	11.4	15 kg (33 lbs.)
GRAHL-60D■	120	3100	25.8	17 kg (37 lbs.)
	120/208	3100	16.0	17 kg (37 lbs.)
	120/240	3100	14.2	17 kg (37 lbs.)
	100	3100	31.0	17 kg (37 lbs.)
	100/200	3100	17.0	17 kg (37 lbs.)
	220♦	3100	14.1	17 kg (37 lbs.)
	240♦	3100	12.9	17 kg (37 lbs.)

Model	Voltage	Watts	Amps	Shipping Weight
GRAHL-66D■	120	3420	28.5	18 kg (40 lbs.)
	120/208	3420	17.5	18 kg (40 lbs.)
	120/240	3420	15.5	18 kg (40 lbs.)
	100	3420	34.2	18 kg (40 lbs.)
	100/200	3420	18.6	18 kg (40 lbs.)
	220♦	3420	15.5	18 kg (40 lbs.)
	240♦	3420	14.3	18 kg (40 lbs.)
GRAHL-72D■	120	3810	31.8	19 kg (42 lbs.)
	120/208	3810	19.6	19 kg (42 lbs.)
	120/240	3810	17.4	19 kg (42 lbs.)
	100	3810	38.1	19 kg (42 lbs.)
	100/200	3810	20.9	19 kg (42 lbs.)
	220♦	3810	17.3	19 kg (42 lbs.)
	240♦	3810	15.9	19 kg (42 lbs.)
GRAHL-84D†■	120	4520	37.7	21 kg (47 lbs.)
	120/208	4520	23.2	21 kg (47 lbs.)
	120/240	4520	20.6	21 kg (47 lbs.)
	100	4520	45.2	21 kg (47 lbs.)
	100/200	4520	24.7	21 kg (47 lbs.)
	220♦	4520	20.5	21 kg (47 lbs.)
	240♦	4520	18.8	21 kg (47 lbs.)
GRAHL-96D†■	120	5280	44.0	25 kg (56 lbs.)
	120/208	5280	27.1	25 kg (56 lbs.)
	120/240	5280	24.0	25 kg (56 lbs.)
	100	5280	52.8	25 kg (56 lbs.)
	100/200	5280	28.8	25 kg (56 lbs.)
	220♦	5280	24.0	25 kg (56 lbs.)
	240♦	5280	22.0	25 kg (56 lbs.)
GRAHL-108D†■	120	5540	46.2	29 kg (64 lbs.)
	120/208	5540	28.5	29 kg (64 lbs.)
	120/240	5540	25.3	29 kg (64 lbs.)
	100	5540	55.4	29 kg (64 lbs.)
	100/200	5540	30.4	29 kg (64 lbs.)
	220♦	5540	25.2	29 kg (64 lbs.)
	240♦	5540	23.1	29 kg (64 lbs.)
GRAHL-120D†*	120/208	6200	31.9	33 kg (72 lbs.)
	120/240	6200	28.3	33 kg (72 lbs.)
	100	6200	---	33 kg (72 lbs.)
	100/200	6200	34.0	33 kg (72 lbs.)
	220♦	6200	28.2	33 kg (72 lbs.)
	240♦	6200	25.8	33 kg (72 lbs.)
	GRAHL-132D†*	120/208	6900	35.5
120/240		6900	31.5	36 kg (79 lbs.)
100		6900	---	36 kg (79 lbs.)
100/200		6900	37.8	36 kg (79 lbs.)
220♦		6900	31.4	36 kg (79 lbs.)
240♦		6900	28.8	36 kg (79 lbs.)
GRAHL-144D†*		120/208	7620	39.2
	120/240	7620	34.8	39 kg (86 lbs.)
	100	7620	---	39 kg (86 lbs.)
	100/200	7620	41.7	39 kg (86 lbs.)
	220♦	7620	34.6	39 kg (86 lbs.)
	240♦	7620	31.8	39 kg (86 lbs.)

**NOTE:** GRAL and GRAHL models that have multiple voltages listed, such as 120/208, 120/240 or 100/200, have multiple circuits. For example, a 120/208 V unit utilizes 120 V for the light circuit and 208 V for the heat circuit(s). Consult the electrical diagram supplied with the unit for specific information.



Strip heaters equipped with incandescent lights that require a circuit breaker larger than 20 amps for the heat element must have a separate circuit breaker for the incandescent lights that is 20 amps or less.

**Electrical Rating Chart — GRN Models**

Model	Voltage	Watts	Amps	Shipping Weight
GRN-18	120	250	2.1	3 kg (6 lbs.)
	208	250	1.2	3 kg (6 lbs.)
	240	250	1.0	3 kg (6 lbs.)
	100	250	2.5	3 kg (6 lbs.)
	200	250	1.3	3 kg (6 lbs.)
	220♦	250	1.1	3 kg (6 lbs.)
	240♦	250	1.0	3 kg (6 lbs.)
GRN-24	120	350	2.9	3 kg (7 lbs.)
	208	350	1.7	3 kg (7 lbs.)
	240	350	1.5	3 kg (7 lbs.)
	100	350	3.5	3 kg (7 lbs.)
	200	350	1.8	3 kg (7 lbs.)
	220♦	350	1.6	3 kg (7 lbs.)
	240♦	350	1.5	3 kg (7 lbs.)
GRN-30	120	450	3.8	4 kg (8 lbs.)
	208	450	2.2	4 kg (8 lbs.)
	240	450	1.9	4 kg (8 lbs.)
	100	450	4.5	4 kg (8 lbs.)
	200	450	2.3	4 kg (8 lbs.)
	220♦	450	2.1	4 kg (8 lbs.)
	240♦	450	1.9	4 kg (8 lbs.)
GRN-36	120	575	4.8	4 kg (9 lbs.)
	208	575	2.8	4 kg (9 lbs.)
	240	575	2.4	4 kg (9 lbs.)
	100	575	5.8	4 kg (9 lbs.)
	200	575	2.9	4 kg (9 lbs.)
	220♦	575	2.6	4 kg (9 lbs.)
	240♦	575	2.4	4 kg (9 lbs.)
GRN-42	120	675	5.6	5 kg (10 lbs.)
	208	675	3.2	5 kg (10 lbs.)
	240	675	2.8	5 kg (10 lbs.)
	100	675	6.8	5 kg (10 lbs.)
	200	675	3.4	5 kg (10 lbs.)
	220♦	675	3.1	5 kg (10 lbs.)
	240♦	675	2.8	5 kg (10 lbs.)

Model	Voltage	Watts	Amps	Shipping Weight
GRN-48	120	800	6.7	5 kg (11 lbs.)
	208	800	3.8	5 kg (11 lbs.)
	240	800	3.3	5 kg (11 lbs.)
	100	800	8.0	5 kg (11 lbs.)
	200	800	4.0	5 kg (11 lbs.)
	220♦	800	3.6	5 kg (11 lbs.)
	240♦	800	3.3	5 kg (11 lbs.)
GRN-54	120	925	7.7	6 kg (13 lbs.)
	208	925	4.4	6 kg (13 lbs.)
	240	925	3.9	6 kg (13 lbs.)
	100	925	9.3	6 kg (13 lbs.)
	200	925	4.6	6 kg (13 lbs.)
	220♦	925	4.2	6 kg (13 lbs.)
	240♦	925	3.9	6 kg (13 lbs.)
GRN-60	120	1050	8.8	6 kg (14 lbs.)
	208	1050	5.0	6 kg (14 lbs.)
	240	1050	4.4	6 kg (14 lbs.)
	100	1050	10.5	6 kg (14 lbs.)
	200	1050	5.3	6 kg (14 lbs.)
	220♦	1050	4.8	6 kg (14 lbs.)
	240♦	1050	4.4	6 kg (14 lbs.)
GRN-66	120	1160	9.7	7 kg (16 lbs.)
	208	1160	5.6	7 kg (16 lbs.)
	240	1160	4.8	7 kg (16 lbs.)
	100	1160	11.6	7 kg (16 lbs.)
	200	1160	5.8	7 kg (16 lbs.)
	220♦	1160	5.3	7 kg (16 lbs.)
	240♦	1160	4.8	7 kg (16 lbs.)
GRN-72	120	1275	10.6	8 kg (17 lbs.)
	208	1275	6.1	8 kg (17 lbs.)
	240	1275	5.3	8 kg (17 lbs.)
	100	1275	12.8	8 kg (17 lbs.)
	200	1275	6.4	8 kg (17 lbs.)
	220♦	1275	5.8	8 kg (17 lbs.)
	240♦	1275	5.3	8 kg (17 lbs.)

The shaded areas contain electrical information for **International models only**.

\* Not available in 100 or 120 V.

♦ CE approved units for 220–230 V utilize a 220 V heating system; 230–240 V CE units utilize a 240 V heating system.

• 100 V and 120 V models with infinite switch require tandem (end-to-end) elements, consult factory for applications.

■ 100 V and 120 V models may require additional switches, consult factory for applications.

† Glo-Ray models 108"–144" and 120 V models of GRA-84 and GRA-96 contain tandem (end-to-end) elements that may be individually controlled.

**Electrical Rating Chart — GRNH Models**

Model	Voltage	Watts	Amps	Shipping Weight
GRNH-18	120	350	2.9	3 kg (6 lbs.)
	208	350	1.7	3 kg (6 lbs.)
	240	350	1.5	3 kg (6 lbs.)
	100	350	3.5	3 kg (6 lbs.)
	200	350	1.8	3 kg (6 lbs.)
	220♦	350	1.6	3 kg (6 lbs.)
	240♦	350	1.5	3 kg (6 lbs.)
GRNH-24	120	500	4.2	3 kg (7 lbs.)
	208	500	2.4	3 kg (7 lbs.)
	240	500	2.1	3 kg (7 lbs.)
	100	500	5.0	3 kg (7 lbs.)
	200	500	2.5	3 kg (7 lbs.)
	220♦	500	2.3	3 kg (7 lbs.)
	240♦	500	2.1	3 kg (7 lbs.)
GRNH-30	120	660	5.5	4 kg (8 lbs.)
	208	660	3.2	4 kg (8 lbs.)
	240	660	2.8	4 kg (8 lbs.)
	100	660	6.6	4 kg (8 lbs.)
	200	660	3.3	4 kg (8 lbs.)
	220♦	660	3.0	4 kg (8 lbs.)
	240♦	660	2.8	4 kg (8 lbs.)
GRNH-36	120	800	6.7	4 kg (9 lbs.)
	208	800	3.8	4 kg (9 lbs.)
	240	800	3.3	4 kg (9 lbs.)
	100	800	8.0	4 kg (9 lbs.)
	200	800	4.0	4 kg (9 lbs.)
	220♦	800	3.6	4 kg (9 lbs.)
	240♦	800	3.3	4 kg (9 lbs.)
GRNH-42	120	950	7.9	5 kg (10 lbs.)
	208	950	4.6	5 kg (10 lbs.)
	240	950	4.0	5 kg (10 lbs.)
	100	950	9.5	5 kg (10 lbs.)
	200	950	4.8	5 kg (10 lbs.)
	220♦	950	4.3	5 kg (10 lbs.)
	240♦	950	4.0	5 kg (10 lbs.)

Model	Voltage	Watts	Amps	Shipping Weight
GRNH-48	120	1100	9.2	5 kg (11 lbs.)
	208	1100	5.3	5 kg (11 lbs.)
	240	1100	4.6	5 kg (11 lbs.)
	100	1100	11.0	5 kg (11 lbs.)
	200	1100	5.5	5 kg (11 lbs.)
	220♦	1100	5.0	5 kg (11 lbs.)
	240♦	1100	4.6	5 kg (11 lbs.)
GRNH-54	120	1250	10.4	6 kg (13 lbs.)
	208	1250	6.0	6 kg (13 lbs.)
	240	1250	5.2	6 kg (13 lbs.)
	100	1250	12.5	6 kg (13 lbs.)
	200	1250	6.3	6 kg (13 lbs.)
	220♦	1250	5.7	6 kg (13 lbs.)
	240♦	1250	5.2	6 kg (13 lbs.)
GRNH-60	120	1400	11.7	6 kg (14 lbs.)
	208	1400	6.7	6 kg (14 lbs.)
	240	1400	5.8	6 kg (14 lbs.)
	100	1400	14.0	6 kg (14 lbs.)
	200	1400	7.0	6 kg (14 lbs.)
	220♦	1400	6.4	6 kg (14 lbs.)
	240♦	1400	5.8	6 kg (14 lbs.)
GRNH-66‡	120	1560	13.0	7 kg (16 lbs.)
	208	1560	7.5	7 kg (16 lbs.)
	240	1560	6.5	7 kg (16 lbs.)
	100	1560	15.6	7 kg (16 lbs.)
	200	1560	7.8	7 kg (16 lbs.)
	220♦	1560	7.1	7 kg (16 lbs.)
	240♦	1560	6.5	7 kg (16 lbs.)
GRNH-72‡	120	1725	14.4	8 kg (17 lbs.)
	208	1725	8.3	8 kg (17 lbs.)
	240	1725	7.2	8 kg (17 lbs.)
	100	1725	17.3	8 kg (17 lbs.)
	200	1725	8.6	8 kg (17 lbs.)
	220♦	1725	7.8	8 kg (17 lbs.)
	240♦	1725	7.2	8 kg (17 lbs.)

The shaded areas contain electrical information for **International models only**.

‡ 120 V model not available for use with a remote infinite switch.

♦ CE approved units for 220–230 V utilize a 220 V heating system; 230–240 V CE units utilize a 240 V heating system.



Dimensions

Model	Width (A)	Height (B)	Depth (C)	Depth (D)	Height (E)
GR and GRH	457–2438 mm (18"–96")	63 mm (2-1/2")	152 mm (6")	---	---
GRA and GRAH	457–3658 mm (18"–144")	63 mm (2-1/2")	152 mm (6")	584 mm (23")	102 mm (4")
GRAL and GRAHL	457–3658 mm (18"–144")	63 mm (2-1/2")	229 mm (9")	660 mm (26")	102 mm (4")
GRL and GRHL	457–1829 mm (18"–72")	63 mm (2-1/2")	229 mm (9")	660 mm (26")	102 mm (4")
GRA-XXD, GRAH-XXD, GRAL-XXD, and GRAHL-XXD	457–3658 mm (18"–144")	63 mm (2-1/2")	381 mm (15")	813 mm (32")	102 mm (4")
GRN and GRNH	457–1829 mm (18"–72")	51 mm (2")	102 mm (4")	---	---

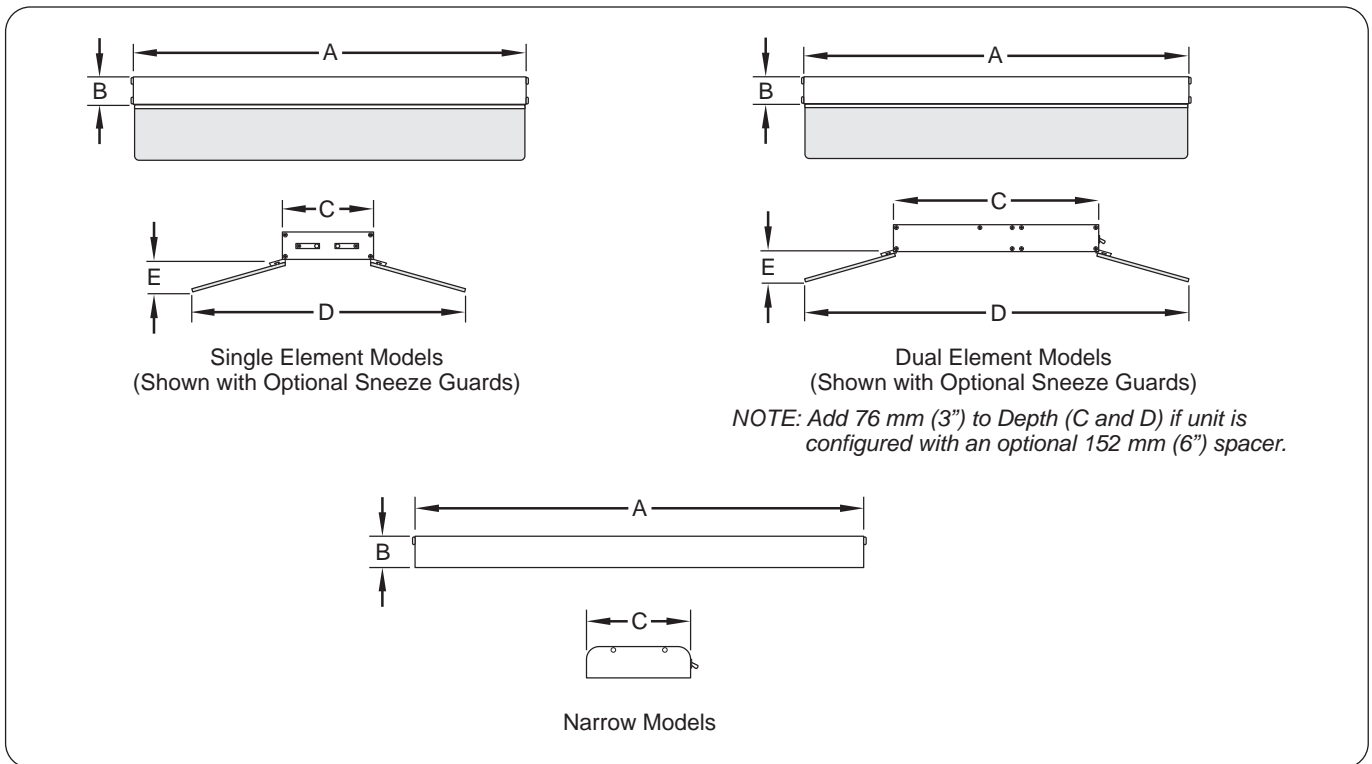

Figure 7. Dimensions

## General

Use the information in this section to prepare for and install an Infrared Strip Heater. Make sure to locate the specific information for the type of installation. Infrared strip heaters are shipped with most components pre-assembled. Dual units are supplied with a required 76 mm (3") or 152 mm (6") spacer pre-assembled at the factory.

### WARNING

#### FIRE HAZARD:

- **Locate the unit the correct distance from combustible walls and materials. If safe distances are not maintained, discoloration or combustion could occur. Refer to specific installation and mounting information in this manual for proper clearances.**
- **Make sure to follow the installation information listed below for specific strip heaters. If safe distances are not maintained, discoloration or combustion could occur.**
  - a. **Do not install standard wattage strip heaters (GR, GRA, GRN, GRAL Series) less than 254 mm (10") above combustible surfaces.**
  - b. **Do not install high wattage strip heaters (GRH, GRAH, GRNH, GRAHL Series) less than 343 mm (13-1/2") above combustible surfaces.**
  - c. **Do not install dual strip heaters (GRA-XXD, GRAH-XXD, GRAL-XXD, and GRAHL-XXD Series) above combustible surfaces.**
  - d. **Install all single strip heaters with a minimum distance of 76 mm (3") from a combustible wall or adjacent surface.**

### CAUTION

Ensure safe and proper operation. Refer to the "Minimum Clearance Requirements" listed in the Installation section of this manual.

### NOTICE

Do not add a decorative soffit to hide a pass-through mounted strip heater. Excessive heat can cause unit failure.

Damage to any countertop material caused by heat generated from Hatco equipment is not covered under the Hatco warranty. Contact the manufacturer of the countertop material for application information.

*NOTE: Contact the countertop manufacturer of the base material for application information and surface temperature limits before installing the unit.*

1. Remove the unit from the shipping carton and remove all packing materials.

*NOTE: To prevent delay in obtaining warranty coverage, complete online warranty registration. See the IMPORTANT OWNER INFORMATION section for details.*

2. Remove tape and protective packaging from all surfaces of the unit.

*NOTE: If the unit is configured with optional equipment, see the OPTIONS AND ACCESSORIES section in this manual.*

3. Install/mount the unit in an appropriate location.
  - a. Verify recommended mounting heights and minimum clearance requirements are met for the appropriate model. Refer to "Recommended Mounting Heights" and "Minimum Clearance Requirements" in this section.
  - b. For portable unit installation, refer to "Installing Portable Units" in this section.
  - c. For chain suspension installation, refer to "Installing Chain Suspended Units" in this section.
  - d. For permanent unit installation, refer to "Installing Permanent Units" in this section.

## Dual Mounting

When mounting units side-by-side, a space not less than 76 mm (3") must be maintained between units. Dual units ordered from the factory are shipped with a pre-assembled 76 mm (3") or 152 mm (6") spacer.

*NOTE: Dual units are available with aluminum housings only.*

### NOTICE

**Installation of two or more separate units with less than 3" (76 mm) between housings may result in premature failure of component parts. Failure to provide proper spacing may result in heat damage to electrical components and are not covered by warranty.**

## Under Shelf Mounting

When mounting a unit under a shelf, use angle brackets to assure proper spacing. Remote control enclosures are recommended to keep switches out of the heat zone and prevent premature failure.

## Pass-Through

If pass-through area is 305–406 mm (12"–16") deep, the standard wattage or high wattage single unit can be used. For a 508–610 mm (20"–24") deep pass-through area, a dual unit in either standard or high wattage is recommended. Installation of multiple units must have a minimum spacing of 76 mm (3") between heaters.

## T-Legs or C-Legs

Do not mount units longer than 1524 mm (60") on T-legs or C-legs.

## Over Steam Table

When mounting over a steam table, a remote control enclosure must be installed.

**Recommended Mounting Heights**

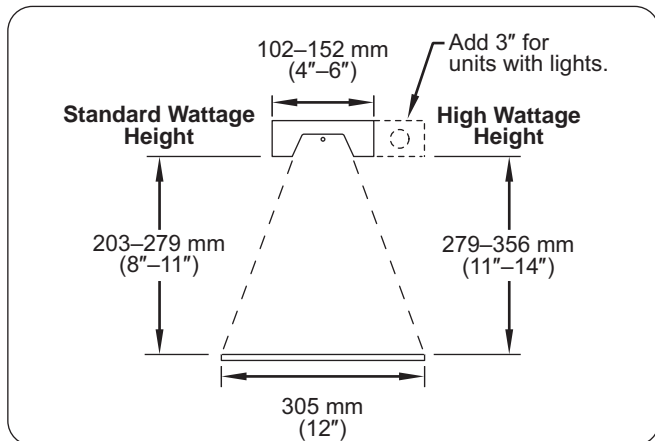

Figure 8. Recommended Element Height for the GR, GRA, GRH, GRN, GRAH, GRAL, GRNH, and GRAHL models in all lengths (excluding dual models).

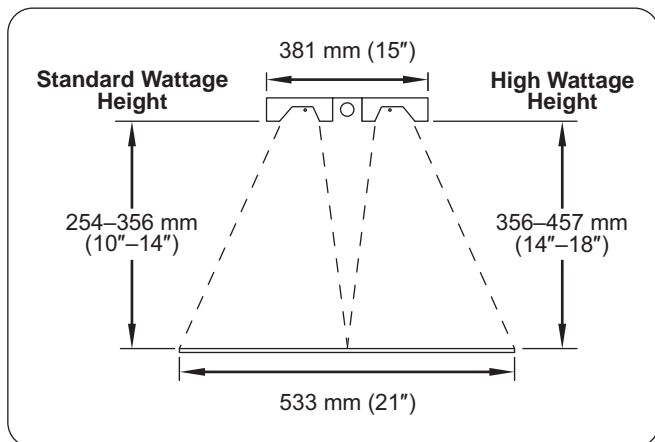

Figure 9. Recommended Element Height for the GRA-D, GRAH-D, GRAL-D & GRAHL-D dual models 76 mm with a (3") spacer in all lengths.

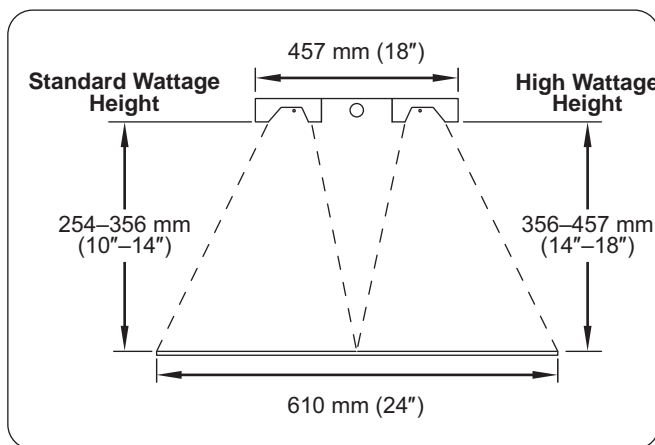

Figure 10. Recommended Element Height for the GRA-D, GRAH-D, GRAL-D & GRAHL-D dual models with a 152 mm (6") spacer in all lengths.

**Minimum Clearance Requirements for Combustible Surroundings**

Models	(A)	(B)	(C)
GRA and GRAL	254 mm (10")	76 mm (3")	25 mm (1")
GRAH and GRAHL	343 mm (13-1/2")	76 mm (3")	25 mm (1")

NOTE: Dual strip heaters cannot be installed in combustible surroundings.

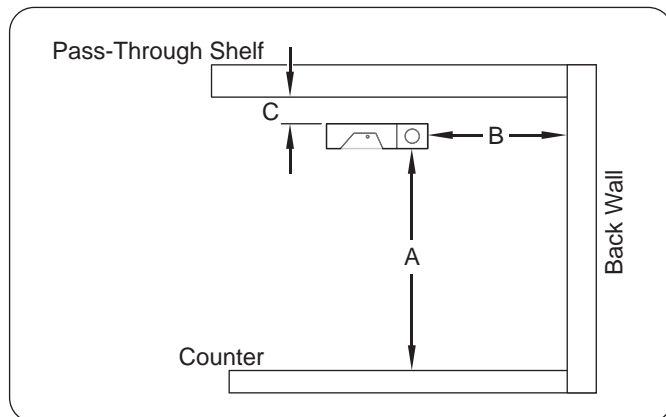

Figure 11. Combustible Clearance Requirements

NOTE: The size of heat patterns vary depending on the height of the unit.

**Minimum Clearance Requirements for Non-Combustible Surroundings**

**Corded Units with Built-In Switches**

Models	(A)	(B)*	(C)
GRA and GRAL	253 mm (10")	---	76 mm (3")
GRAH and GRAHL	279 mm (11")	---	76 mm (3")

**Hardwired Units with Built-In Switches**

Models	(A)	(B)*	(C)
GRA and GRAL	203 mm (8")	---	25 mm (1")
GRAH and GRAHL with Infinite Heat Control or Indicator Light	253 mm (10")	---	25 mm (1")
GRAH and GRAHL with ON/OFF Toggle Switch	203 mm (8")	---	25 mm (1")

**Hardwired Units with Remote Switches**

Models	(A)	(B)*	(C)
GRA and GRAL	203 mm (8")	0 mm (0")	0 mm (0")
GRAH and GRAHL	203 mm (8")	0 mm (0")	0 mm (0")

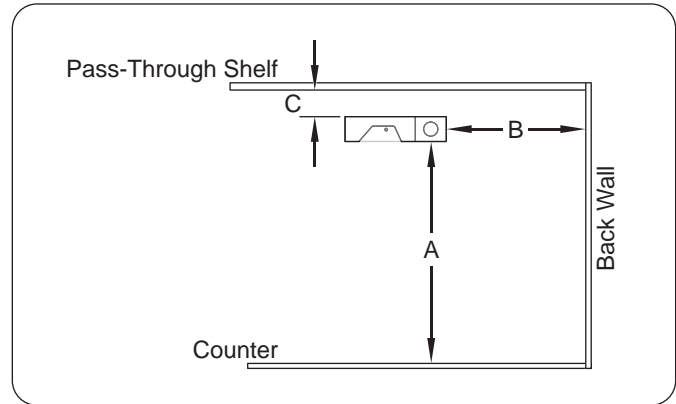

Figure 12. Non-Combustible Clearance Requirements

**Dual Units with Built-In Switches**

Models	(A)	(B)*	(C)
GRA-XXD GRAH-XXD GRAL-XXD GRAHL-XXD	253 mm (10")	---	25 mm (1")

**Dual Units with Remote Switches**

Models	(A)	(B)*	(C)
GRA-XXD GRAH-XXD GRAL-XXD GRAHL-XXD	203 mm (8")	76 mm (3")	0 mm (0")

\* Must be a pass-through application, not allowed with back wall installation.

### Installing Portable Units

Single strip heater units under 1524 mm (60") long can be mounted on C-Leg or T-Leg stands for portable use. Portable units are available in 120 V only and are required to have a power cord and plug connection.

**NOTE:** C-Legs and T-Legs are not to be used with dual strip heater units.

#### C-Leg Stand Mounting

Two types of C-Legs are available.

- CL-Low = 254 mm (10") height, for standard wattage strip heaters up to 1524 mm (5') in width only.
- CL-High = 343 mm (13-1/2") height, for high wattage strip heaters up to 1524 mm (5') in width only.

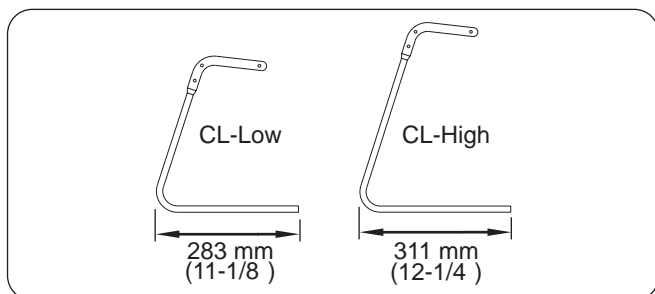

Figure 13. C-Leg Footprint Dimensions

Perform the following procedure to install a C-Leg stand on each end of the unit.

1. Position the unit upside-down on a flat surface.
2. Install sneeze guard(s), if applicable (refer to the OPTIONS AND ACCESSORIES section for details on installing a sneeze guard).
3. Remove the two hanger tab screws and hanger tabs.
4. Remove the one end plate screw that aligns with the lowest mounting hole on the C-Leg.
5. Align the three mounting holes on the C-Leg with the three holes on the unit. Secure the leg to the unit with the three screws removed in the previous steps.

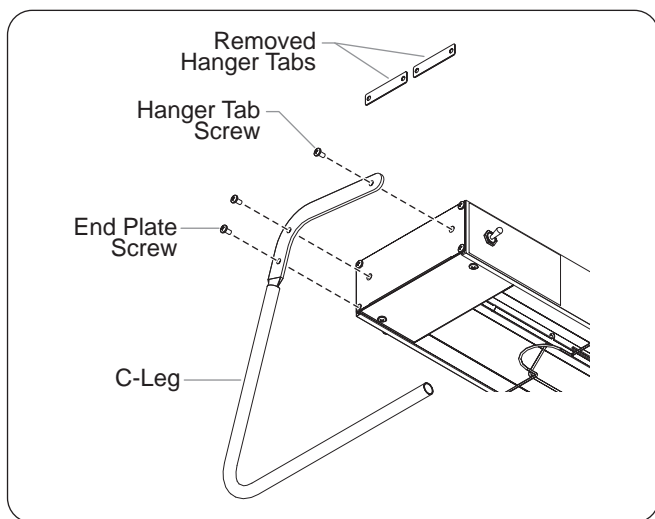

Figure 14. C-Leg Stand

#### T-Leg Stand Mounting

T-Leg stands are available in the following heights:

- Standard wattage units = 254 mm (10")
- High wattage units = 343 mm (13-1/2")  
406 mm (16")  
457 mm (18").

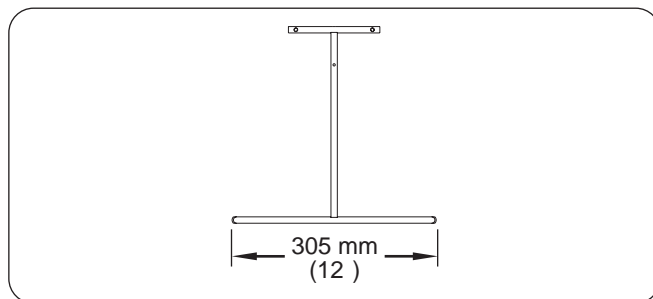

Figure 15. T-Leg Footprint Dimension

Perform the following procedure to install a T-Leg stand on each end of the unit.

1. Position the unit upside-down on a flat surface.
2. Install sneeze guard(s), if applicable (refer to the OPTIONS AND ACCESSORIES section for details on installing a sneeze guard).
3. Align the mounting bracket with the end cover on the underside of the unit, and remove the two screws on the end cover that match up with the holes on the mounting bracket.
4. Secure the mounting bracket to the unit with the two end cover screws.
5. Remove the two hanger tab screws and hanger tabs.
6. Align the two mounting holes on the small "T" of the T-Leg with the two hanger tab holes on the end of the unit. Secure the leg to the unit with the hanger tab screws.
7. Align the single mounting hole on the vertical post of the T-Leg with the hole on the mounting bracket. Secure from the inside with the supplied screw.

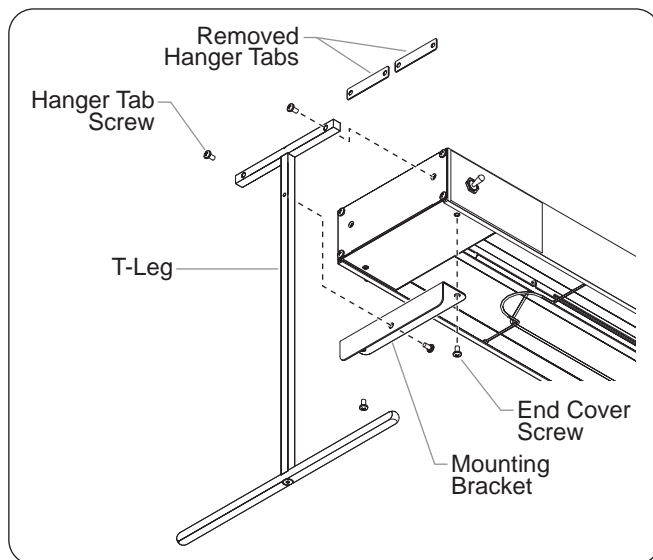

Figure 16. T-Leg Stand End Mounting

## Installing Chain Suspended Units

Chain suspended mounting attaches the unit to an overhead surface with the use of “S” hooks. “S” hook mounted units are available in 120 V only and are required to have a power cord and plug connection.

*NOTE: Units ordered with the “S” hook option come with two “S” hooks and two 152 mm (6”) lengths of chain. Additional chain (P/N 05.03.020.00) can be ordered from Hatco for the overhead mounting system or another option can be determined by a qualified installer.*



**For installation with chains, make sure the chains have sufficient strength and are securely fastened to both the unit and the mounting location. Poorly installed chains may cause the unit to loosen and fall. Do not place anything on top of units installed with chains.**

**Ensure safe and proper operation. Refer to the “Minimum Clearance Requirements” listed in the Installation section of this manual.**

*NOTE: The strength of the chain supplied by Hatco is sufficient to hold the weight of the unit securely only when mounted properly.*

1. Prepare the overhead mounting system for the “S” hooks. Make sure the system is secure and is set up so the unit will be suspended at a level, safe, and proper distance from walls, counter, and food.
2. Loosen, but do not remove the screws securing the hanger tabs on each end of the unit. Rotate the tabs up, then tighten the screws securely.
3. Securely attach one of the 152 mm (6”) connecting chains between each pair of hanger tabs.
4. Attach an “S” hook to the center of each connecting chain.
5. Carefully lift the unit and attach the “S” hooks on each end of the unit to the overhead mounting system. Make sure the unit is level.

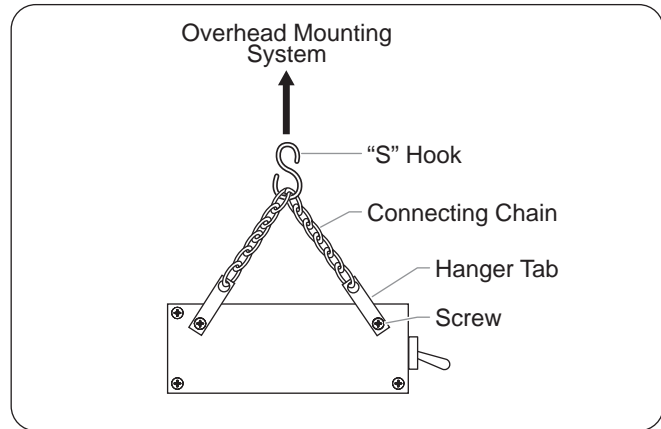

Figure 17. “S” Hook Mounting

### Installing Permanent Units

Strip heater units can be mounted permanently with tubular stands or angle brackets. Permanent units are not available with a power cord and plug connection. Refer to the proper permanent mounting section for the installation procedure.

#### Tubular Stand Mounting

Tubular stand mounting permanently attaches the unit to a countertop or serving table. All wiring may be concealed within one of the tubular stands.



**Ensure safe and proper operation. Refer to the “Minimum Clearance Requirements” listed in the Installation section of this manual.**

Non-adjustable tubular stands are available in aluminum, Designer colors, or gloss finishes in heights from 254–406 mm (10”–16”). Adjustable tubular stands are available in stainless steel in heights from 254–356 mm (10”–14”).

*NOTE: Tubular stands cannot be retrofitted in the field.*

*NOTE: If wiring is to be concealed, a 25 mm (1”) diameter hole must be provided in the mounting surface centered under the stand containing the wiring conduit.*

1. Position the unit upside-down on a flat surface.

*NOTE: Units for this application are supplied with the conduit attached to one side of the unit. Conduit should not be removed.*

2. If applicable, prepare the mounting surface for concealing wiring.
  - a. Cut a 25 mm (1”) diameter hole into the mounting surface at the appropriate location.

*NOTE: The distance between the center of the two stands is found by subtracting 62 mm (2-7/16”) from the overall width of the strip heater.*

- b. Route the flexible conduit through the tubular stand and into the mounting surface.

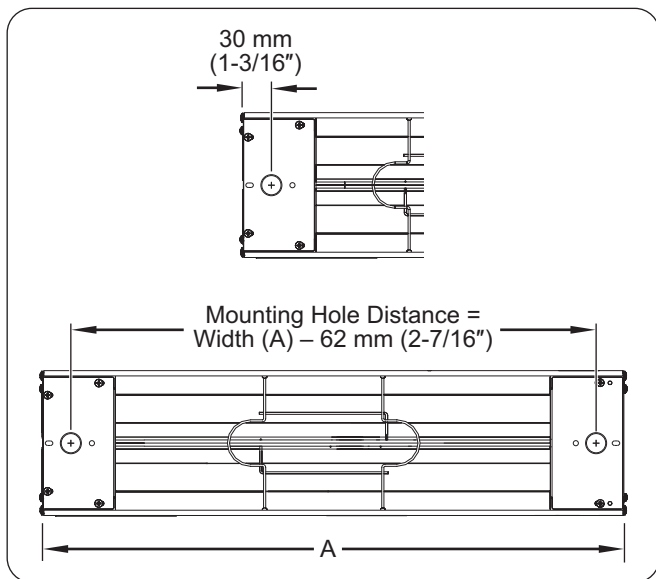

Figure 18. Countertop Conduit Hole Dimension

3. Secure the conduit-side stand to the unit using the screws supplied.
4. Align the opposite-side stand with the mounting holes at the other end of the unit and secure the stand to the unit using the screws supplied.
5. Secure the stands to the mounting surface.

*NOTE: The adjustable stands can be raised or lowered by turning the locking set screw counterclockwise one turn with a hex wrench. After loosening the set screw, raise or lower the unit to the desired height and retighten the screw. Do not loosen the screw more than necessary.*

*NOTE: Two pairs of tubular stands will be needed for mounting dual units.*

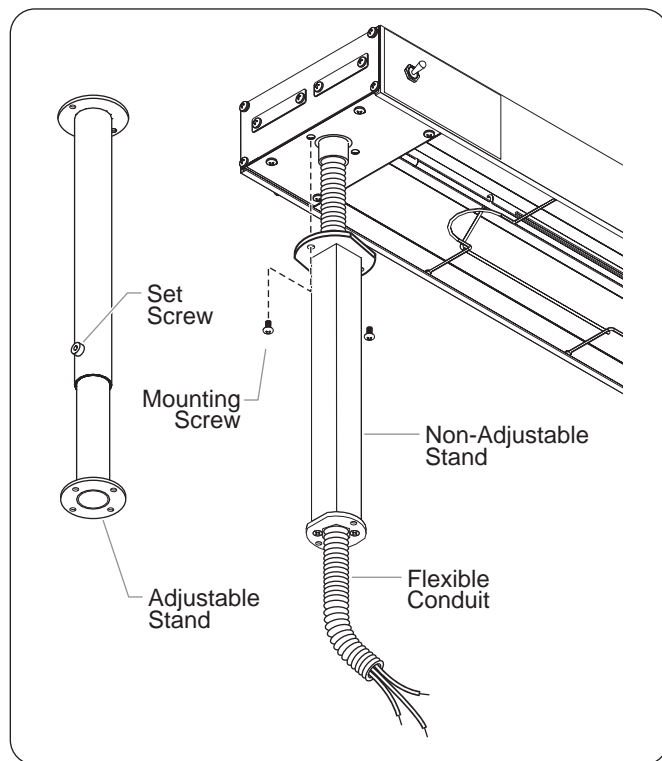

Figure 19. Tubular Stand Mounting

## Angle Bracket Mounting

Mounting a unit with an angle bracket permanently attaches the unit to the underside of a shelf. It can be mounted to a flat shelf or a shelf with rolled/flanged edges. The adjustable angle brackets will provide the necessary gap between the unit and a combustible shelf.



**Ensure safe and proper operation. Refer to the “Minimum Clearance Requirements” listed in the Installation section of this manual.**

*NOTE: When mounting the unit under a shelf, it is recommended to use a remote-mounted control switches.*

Use the optional adjustable angle brackets to mount the unit below the lowest part of the rolled or flanged edge of the shelf (a minimum gap of 1" [25 mm] is required between the unit and the underside of a rolled or flanged shelf to prevent heat damage to the electrical system of the unit).

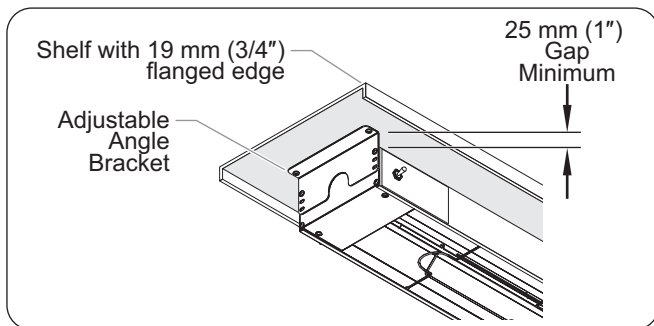

Figure 20. Flanged Edge Shelf Installation

*NOTE: GRN Series units are supplied with matching designer-colored angle brackets providing 1-1/2" (38 mm) clearance between foodwarmer and overshell.*

### Adjustable Angle Bracket Mounting on Aluminum Models

Use the following procedure to install adjustable brackets on each end of aluminum housing models (GRA, GRAH, GRAL, and GRAHL).

1. Position the unit on a flat surface with the heating element facing down.
2. Remove the two hanger tab screws and hanger tabs. These items will not be needed.
3. Remove the two upper end plate screws.
4. Align the adjustable angle bracket to the end plate mounting holes of the unit. Secure the angle bracket with previously removed end plate screws.

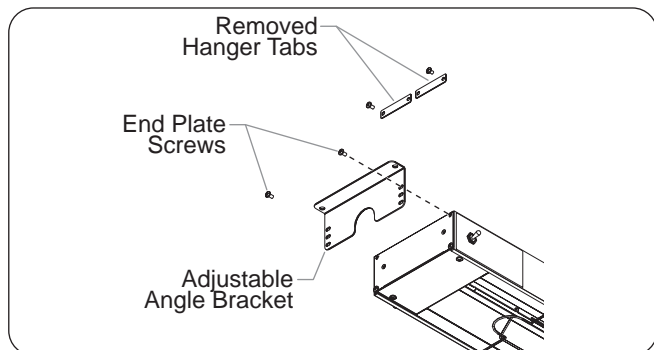

Figure 21. Aluminum Model Adjustable Angle Bracket Installation

5. Fasten the angle bracket to the underside of the shelf using appropriate fasteners (not supplied by Hatco).

*NOTE: Two pairs of brackets will be needed for dual units.*

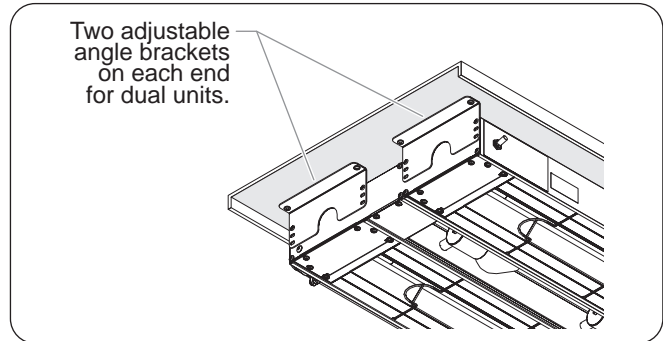

Figure 22. Dual Unit Mounting

### Adjustable Angle Bracket Mounting on Stainless Steel Models

Use the following procedure to install adjustable angle brackets on each end of stainless steel housing models (GR and GRH models).

1. Position the unit on a flat surface with the heating element facing down.
2. Remove the two hanger tab screws and hanger tabs.
3. Align the adjustable angle bracket with the hanger tab mounting holes on the unit.
4. Secure the angle bracket with the previously removed hanger tab screws.
5. Fasten the angle brackets to the underside of the shelf using appropriate fasteners (not supplied by Hatco).

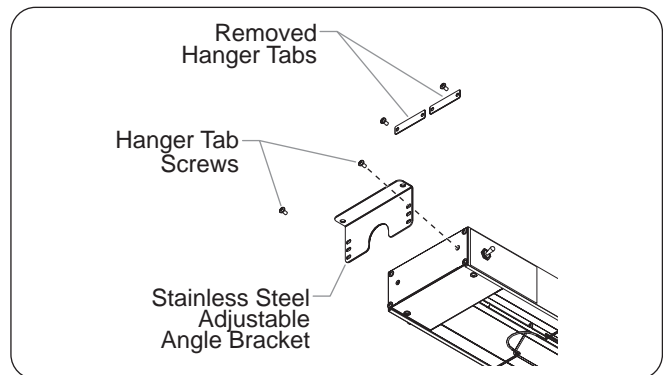

Figure 23. Stainless Steel Model Adjustable Angle Bracket Installation



## Electrical Information

Refer to the appropriate "Electrical Ratings Chart" for unit-specific electrical information.



**ELECTRIC SHOCK HAZARD:** For hardwired units, all electrical connections must be in accordance with local electrical codes and any other applicable codes. Connections should be made by a qualified, licensed electrician.



Strip heaters equipped with incandescent lights that require a circuit breaker larger than 20 amps for the heat element must have a separate circuit breaker for the incandescent lights that is 20 amps or less.

*NOTE: If the unit being installed is not shown or listed in this manual, refer to the wiring diagram supplied with the unit and the installation information on the unit for further instructions.*

### Power Supply

Install supply wire and connectors suitable for at least 90°C (194°F).

- Use a minimum of No. 14 AWG copper wire for individual circuits up to 15 amps.
- Use a minimum of No. 12 AWG copper wire for individual circuits 15 to 20 amps.
- Use a minimum of No. 10 AWG copper wire for individual circuits 20 to 25 amps.
- Use a minimum of No. 8 AWG copper wire for individual circuits 25 to 30 amps.

*NOTE: Refer to the wiring diagram supplied with the unit and specifications label attached to the unit for specific electrical information.*

### Conduit Connection

Units supplied with a right angle fitting and flexible conduit attached have had all internal connections completed at the factory. Attach the proper power supply leads to the high temperature lead wires in the conduit.

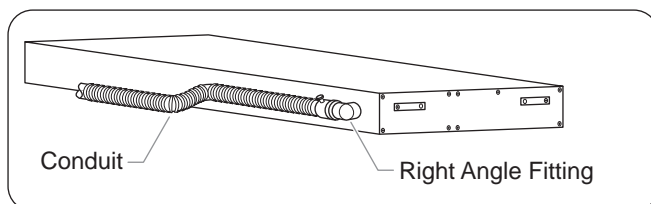

Figure 24. Conduit Connections

*NOTE: Refer to the wiring diagram supplied with the unit and specifications label attached to the unit for specific electrical information.*

### Power Cord and Plug Models

Units can be supplied with a 1829 mm (6') power cord and plug attached at the factory if the unit meets the following guidelines:

- 120 volt unit
- Single heating element
- 1829 mm (72") or less in length
- Built-in switch
- Portable mounting using C-Legs or T-Legs supplied by Hatco or stationary mounting using "S" hooks and mounting chain supplied by Hatco.



**ELECTRIC SHOCK HAZARD:** Plug unit into a properly grounded electrical receptacle of the correct voltage, size, and plug configuration. If plug and receptacle do not match, contact a qualified electrician to determine and install proper voltage and size electrical receptacle.

*NOTE: Units intended for fixed or permanent mounting cannot have a power cord attached and must be hardwired according to local and national electrical codes.*

### Remote Control Enclosures

Hatco remote control enclosures include switches, wire leads, and/or indicator lights and are ready for installation.

The RMB Series require one remote control enclosure per strip heater. The RMB2 Series allows multiple strip heaters to be connected to one remote control enclosure.

*NOTE: Remote control enclosures are available in several configurations depending on the model. All enclosures are built in accordance with UL standards to accommodate switches, indicator lights, and wiring. See the OPTIONS AND ACCESSORIES section near the back of this manual for more information.*

### NOTICE

**To prevent premature failure of components due to excessive heat, Remote Control Enclosures must be installed outside the strip heater heat zone.**

### Remote Mounted Control Switches

Optional remote mounted control switches include ON/OFF toggle switches and infinite control switches. These switches need to be installed into an approved electrical box/enclosure (not supplied) by a qualified electrician.

*NOTE: When two or more units are mounted where the heat from one housing tends to raise the temperature of another, the control switches should be installed in a remote control enclosure. Units in a multiple installation should use remote control enclosures.*

**General**

Glo-Ray® Infrared Strip Heaters are designed for ease of operation. Use the following information and procedures to operate the unit.



Read all safety messages in the **IMPORTANT SAFETY INFORMATION** section before operating this equipment.



**BURN HAZARD:** Some exterior surfaces on unit will get hot. Avoid unnecessary contact with unit.

**Standard and approved manufacturing oils may smoke up to 30 minutes during initial startup. This is a temporary condition. Operate unit without food product until smoke dissipates.**

**Controls**

Strip heaters come standard with controls mounted to the unit or with optional remote mounted controls. The following is a list of the available controls for the strip heaters.

**ON/OFF (I/O) Toggle Switch**—Turns power on and off to the heating elements and/or the lights.

**Infinite Control**—Turns on the power and controls the temperature of the heating elements. The infinite control is available either built-in or on a remote control enclosure.

*NOTE: Dual units cannot be equipped with built-in infinite controls.*

**Indicator Light**—Illuminates when power is on, shuts off when power is off.

*NOTE: Toggle switches cannot be used on circuits that exceed 15 amps. Infinite controls cannot be used on circuits that exceed 12.2 amps.*

**Startup**

1. Turn on the heating element(s). The indicator light (if equipped) will illuminate and the heating elements will energize.
  - If unit is equipped with a ON/OFF (I/O) toggle switch, move the toggle switch to the ON (I) position.
  - If unit is equipped with an optional infinite control(s), turn the control to the desired setting.

*NOTE: Allow 15-20 minutes to reach operating temperature.*

2. On models equipped with display lights, move the light ON/OFF (I/O) toggle switch to the ON (I) position.



Figure 25. Control Panel with ON/OFF (I/O) Toggle Switch

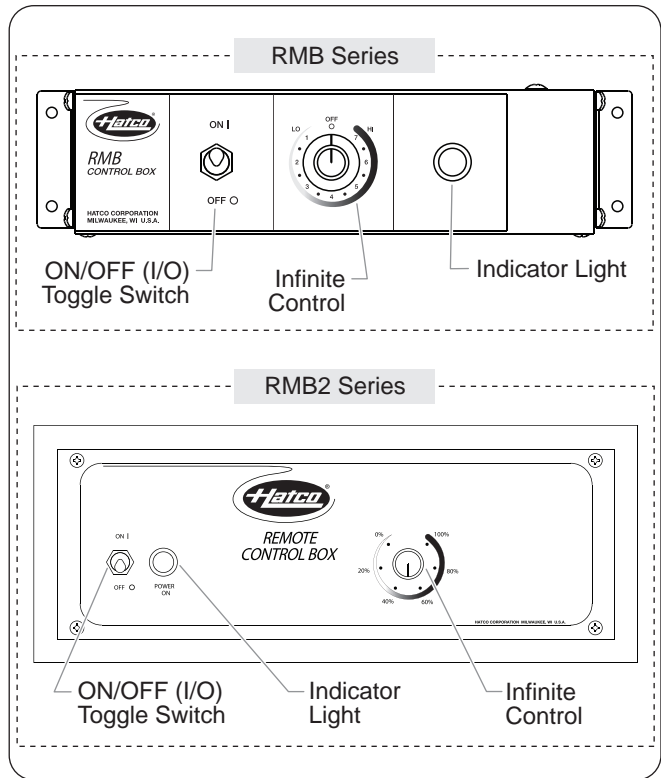

Figure 26. Remote Control Enclosures

*NOTE: Refer to the OPTIONS AND ACCESSORIES section for remote control enclosure information.*

**Shutdown**

1. Move the ON/OFF (I/O) toggle switch to the OFF (O) position or turn the infinite control(s) to the OFF(O) position.
  - The indicator light (if equipped) will shut off and the heating elements will shut down.
2. On models equipped with display lights, move the light ON/OFF (I/O) toggle switch to the OFF (O) position.

## General

The Glo-Ray Infrared Strip Heaters are designed for maximum durability and performance, with minimum maintenance.



### WARNING

#### ELECTRIC SHOCK HAZARD:

- Turn OFF power switch, unplug power cord/turn off power at circuit breaker, and allow unit to cool before performing any cleaning, adjustments, or maintenance.
- DO NOT submerge or saturate with water. Unit is not waterproof. Do not operate if unit has been submerged or saturated with water.
- Do not steam clean or use excessive water on unit.
- This unit is not “jet-proof” construction. Do not use jet-clean spray to clean this unit.
- Use only Genuine Hatco Replacement Parts when service is required. Failure to use Genuine Hatco Replacement Parts will void all warranties and may subject operators of the equipment to hazardous electrical voltage, resulting in electrical shock or burn. Genuine Hatco Replacement Parts are specified to operate safely in the environments in which they are used. Some aftermarket or generic replacement parts do not have the characteristics that will allow them to operate safely in Hatco equipment.

This unit has no “user-serviceable” parts. If service is required on this unit, contact an Authorized Hatco Service Agent or contact the Hatco Service Department at 414-671-6350 or International fax 414-671-3976.

## Cleaning

To preserve the finish of the Glo-Ray Infrared Strip Heater, perform the following cleaning procedure daily.

### NOTICE

Use non-abrasive cleaners and cloths only. Abrasive cleaners and cloths could scratch the finish of the unit, marring its appearance and making it susceptible to soil accumulation.

1. Turn off the unit and allow the unit to cool.
2. Wipe down all metal surfaces with a water-dampened, non-abrasive cloth. Stubborn stains may be removed with a good stainless steel or non-abrasive cleaner. Clean hard to reach areas using a small brush and mild soap.
3. Wipe dry the entire unit using a non-abrasive, dry cloth.

## Replacing A Display Light



### WARNING

Use only light bulbs that meet or exceed National Sanitation Foundation (NSF) standards and are specifically designed for food holding areas. Breakage of light bulbs not specially-coated could result in personal injury and/or food contamination.

The display light is an incandescent bulb that illuminates the warming area. This bulb has a special coating to guard against injury and food contamination in the event of breakage.

To replace a light bulb:

1. Disconnect the power supply and wait until the unit has cooled.
2. Unscrew the light bulb from the unit and replace it with a new, specially-coated incandescent light bulb.

*NOTE: Hatco shatter-resistant light bulbs meet NSF standards for food holding and display areas. For 120, 120/208, 120/240, and 100/200 volt applications, use Hatco P/N 02.30.043.00. For 200, 220, 230, and 240 volt applications, use Hatco P/N 02.30.058.00.*

*NOTE: Halogen bulbs are available as an option. For 120, 120/208, 120/240, and 100/200 volt applications, use Hatco P/N 02.30.081.00. For 200, 220, 230, and 240 volt applications, use Hatco P/N 02.30.082.00.*

**⚠ WARNING**

This unit must be serviced by qualified personnel only. Service by unqualified personnel may lead to electric shock or burn.

**⚠ WARNING**

**ELECTRIC SHOCK HAZARD:** Turn OFF power switch, unplug power cord/turn off power at circuit breaker, and allow unit to cool before performing any cleaning, adjustments, or maintenance.

Symptom	Probable Cause	Corrective Action
Unit is turned ON but there is no heat.	No power to unit.	Check circuit breaker and reset as necessary.
	Switch is defective.	Contact Authorized Service Agent or Hatco for assistance.
	Wiring is open.	Contact Authorized Service Agent or Hatco for assistance.
	Heating element defective.	Contact Authorized Service Agent or Hatco for assistance.
Heat is inadequate.	Unit mounted too high above target area.	Lower unit, putting effective heat closer to target.
	Excessive air movement around strip heater target area.	Restrict or redirect air movement (air conditioning duct or exhaust fan) away from unit.
	Incorrect power supply (low).	Check power supply to unit, making sure it matches rating on the unit. If power supply is incorrect, change to match rating on unit.
Heat is excessive.	Unit mounted too close to target area.	Check to see that installation is within specifications for type/model. Increase mounting height if too close.
	Voltage supply too high.	Check power supply to unit, making sure it matches rating on unit. If power supply is incorrect, change to match rating.
Control switches burn out.	Unit mounted improperly.	Move the unit the proper distance away from walls, counters, and/or pass-through shelves. Refer to the INSTALLATION section for guidelines.
	Remote control enclosure is mounted too close to the heat zone.	Move remote control enclosure away from the heat zone.
	Switches used are not Hatco supplied.	Genuine Hatco Parts are specified to operate safely and properly in the environment in which they are used. Contact Authorized Service Agent or Hatco to replace switches with Genuine Hatco Replacement Parts.

## OPTIONS AND ACCESSORIES

### Sneeze Guards

Optional sneeze guards are available for aluminum models only. They are available in sizes of 238 mm (9-3/8") and 356 mm (14"). Sneeze guards can be installed on either one side or both sides of the unit.

To install a sneeze guard:

1. Remove the protective paper from the sneeze guard.
2. Assemble each tab screw through the top of the sneeze guard and through the support bar. Loosely thread an acorn nut onto each of the tab screws below the support bar.
3. Lift the sneeze guard assembly and carefully slide each of the tab screws that are loosely attached to the sneeze guard into the channel on the unit.
4. Align each end of the sneeze guard with the ends of the unit and then tighten the acorn nuts to secure the sneeze guard in position. Do not over-tighten the acorn nuts.

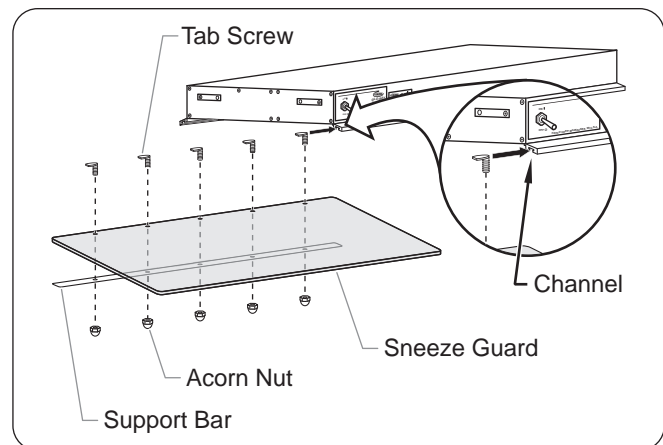

Figure 27. Installing Sneeze Guards

**Remote Control Enclosure — RMB Series**

RMB Series remote control enclosures are available in various configurations for use with strip heaters. Remote control enclosures locate controls away from the heat of the unit, increasing the life span of the controls. All models are built in accordance with UL standards with switches, indicator lights, and wiring. Consult the factory for type and location of RMB Series controls for enclosure.

*NOTE: RMB Series remote control enclosures require one remote control enclosure per strip heater.*

Models	Width (A)	Depth (B)	Height (C)	Screw Width (D)	Screw Height (E)
RMB-3 Series	150 mm (5-15/16")	76 mm (3")	67 mm (2-5/8")	161 mm (6-5/16")	41 mm (1-5/8")
RMB-7 Series	239 mm (9-3/8")	76 mm (3")	67 mm (2-5/8")	249 mm (9-13/16")	41 mm (1-5/8")
RMB-14 Series	366 mm (14-3/8")	76 mm (3")	67 mm (2-5/8")	376 mm (14-13/16")	41 mm (1-5/8")
RMB-16 Series	417 mm (16-3/8")	76 mm (3")	67 mm (2-5/8")	427 mm (16-13/16")	41 mm (1-5/8")
RMB-20 Series	518 mm (20-3/8")	76 mm (3")	67 mm (2-5/8")	529 mm (20-13/16")	41 mm (1-5/8")

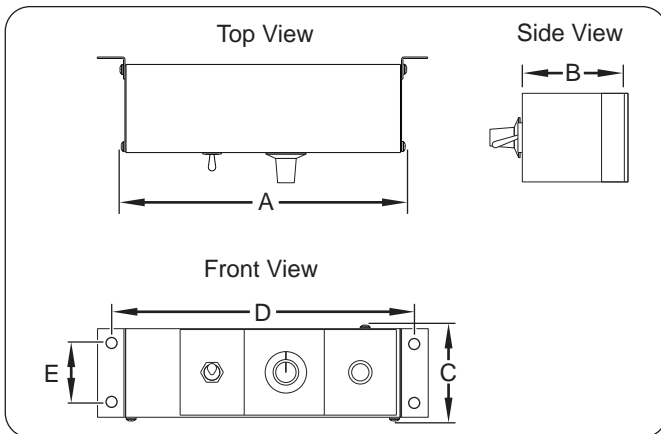

Figure 28. RMB Series Dimensions

**Remote Control Enclosure — RMB2 Series**

RMB2 Series remote control enclosures allow multiple strip heaters to be wired to and controlled by a single enclosure. The total amp draw of all connected strip heaters cannot exceed the rating of the remote control enclosure. Consult the factory for information regarding the proper RMB2 Series remote control enclosure for a specific application.

**RMB2 Series Dimensions**

Models	Width (A)	Width (B)	Height (C)	Depth (D)	Height (E)
RMB2-1R	257 mm (10-1/8")	279 mm (11")	140 mm (5-1/2")	109 mm (4-1/4")	116 mm (4-5/8")
RMB2-2R	333 mm (13-1/8")	356 mm (14")	140 mm (5-1/2")	109 mm (4-1/4")	116 mm (4-5/8")

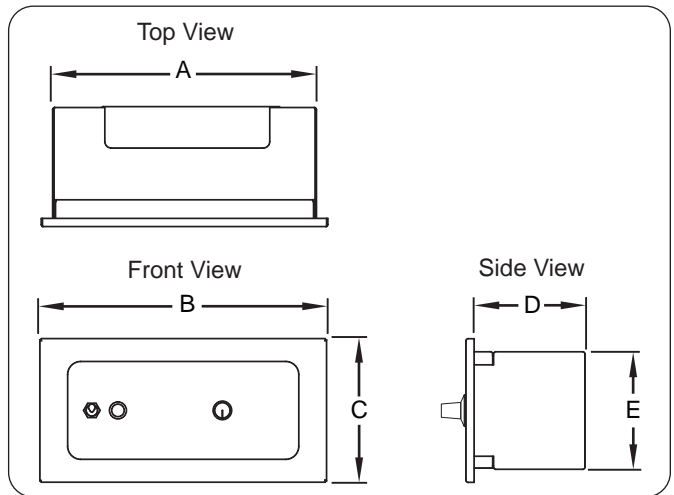

Figure 29. RMB2 Series Dimensions

**RMB2 Series Cutout Dimensions**

Models	Opening Cutout Dimensions		Screw Hole Dimensions		
	(A)	(B)	(C)	(D)	(E)
RMB2-1R	121 mm (4-3/4")	257 mm (10-1/8")	29 mm (1-1/8")	64 mm (2-1/2")	265 mm (10-7/16")
RMB2-2R	121 mm (4-3/4")	333 mm (13-1/8")	29 mm (1-1/8")	64 mm (2-1/2")	341 mm (13-7/16")

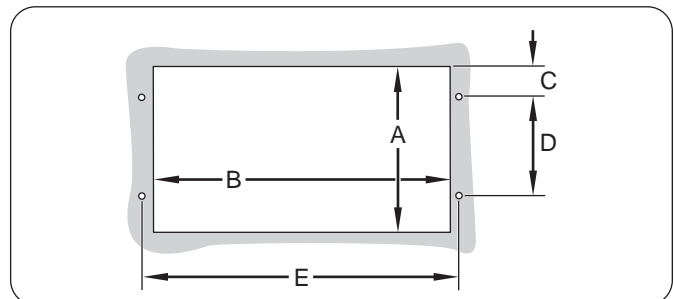

Figure 30. RMB2 Series Cutout Dimensions

## 1. PRODUCT WARRANTY

Hatco warrants the products that it manufactures (the "Products") to be free from defects in materials and workmanship, under normal use and service, for a period of one (1) year from the date of purchase when installed and maintained in accordance with Hatco's written instructions or 18 months from the date of shipment from Hatco. Buyer must establish the Product's purchase date by registering the Product with Hatco or by other means satisfactory to Hatco in its sole discretion.

Hatco warrants the following Product components to be free from defects in materials and workmanship from the date of purchase (subject to the foregoing conditions) for the period(s) of time and on the conditions listed below:

### a) Two (2) Year Parts Warranty:

- Conveyor Toaster Elements (metal sheathed)
- Drawer Warmer Elements (metal sheathed)
- Drawer Warmer Drawer Rollers and Slides
- Strip Heater Elements (metal sheathed)
- Display Warmer Elements (metal sheathed air heating)
- Holding Cabinet Elements (metal sheathed air heating)
- Heated Well Elements — HWB Series (metal sheathed)

### b) One (1) Year Parts PLUS Four (4) Years Parts Warranty on pro-rated terms that Hatco will explain at Buyer's request:

- 3CS and FR Tanks

### c) Ten (10) Year Parts Warranty:

- Electric Booster Heater Tanks
- Gas Booster Heater Tanks

### d) Ninety (90) Day Parts Warranty:

- Replacement Parts

THE FOREGOING WARRANTIES ARE EXCLUSIVE AND IN LIEU OF ANY OTHER WARRANTY, EXPRESSED OR IMPLIED, INCLUDING BUT NOT LIMITED TO ANY IMPLIED WARRANTY OF MERCHANTABILITY OR FITNESS FOR A PARTICULAR PURPOSE OR PATENT OR OTHER INTELLECTUAL PROPERTY RIGHT INFRINGEMENT. Without limiting the generality of the foregoing, SUCH WARRANTIES DO NOT COVER: Coated incandescent light bulbs, fluorescent lights, heat lamp bulbs, coated halogen light bulbs, halogen heat lamp bulbs, xenon light bulbs, LED light tubes, glass components, and fuses; Product failure in booster tank, fin tube heat exchanger, or other water heating equipment caused by liming, sediment buildup, chemical attack, or freezing; or Product misuse, tampering or misapplication, improper installation, or application of improper voltage.

## 2. LIMITATION OF REMEDIES AND DAMAGES

Hatco's liability and Buyer's exclusive remedy hereunder will be limited solely to replacement of part or Product using, at Hatco's option, new or refurbished parts or Product by Hatco or a Hatco-authorized service agency with respect to any claim made within the applicable warranty period referred to above. Hatco reserves the right to accept or reject any such claim in whole or in part. In the context of this Limited Warranty, "refurbished" means a part or Product that has been returned to its original specifications by Hatco or a Hatco-authorized service agency. Hatco will not accept the return of any Product without prior written approval from Hatco, and all such approved returns shall be made at Buyer's sole expense. HATCO WILL NOT BE LIABLE, UNDER ANY CIRCUMSTANCES, FOR CONSEQUENTIAL OR INCIDENTAL DAMAGES, INCLUDING BUT NOT LIMITED TO LABOR COSTS OR LOST PROFITS RESULTING FROM THE USE OF OR INABILITY TO USE THE PRODUCTS OR FROM THE PRODUCTS BEING INCORPORATED IN OR BECOMING A COMPONENT OF ANY OTHER PRODUCT OR GOODS.

## SERVICE INFORMATION

The warranty on Hatco Glo-Ray® Infrared Strip Heaters is for one year from date of purchase or eighteen months from date of shipping from Hatco, whichever occurs first.

If you experience a problem with a Strip Heater during the warranty period, please do the following:

### Contact Local Hatco Dealer

When contacting the Hatco dealer for service assistance, please supply the dealer with the following information to ensure prompt processing:

- Model of unit
- Serial number (located on the back of the unit)
- Specific problem with the unit
- Date of purchase
- Name of business
- Shipping address
- Contact name and phone number

The Hatco dealer will do the following:

- Provide replacement part(s) as required
- Submit warranty claim to Hatco for processing

### Non-Warranty Problems

If you experience a non-warranty problem that requires assistance, please contact the nearest Authorized Hatco Service Agency.

To locate the nearest Service Agency:

- access our website at [www.hatcocorp.com](http://www.hatcocorp.com), select the *Resources* pull-down menu, and click on "Find Service Agent/Distributor"
- call Hatco Service at 414-671-6350
- e-mail Hatco Service at [partsandservice@hatcocorp.com](mailto:partsandservice@hatcocorp.com)