

Original
instructions



Tiepolo

OVEN

Use and maintenance manual

TP435
TP635
TP635L
TP935



HEat.
smART.
Partner in Baking. Since 1963





We congratulate you for choosing a product designed and manufactured with cutting-edge technology.

The oven is checked and tested in the Manufacturer's plant before being delivered to the customer.

The "production process check sheet" enclosed with it guarantees that **each** step in the production process, from assembly to packaging, was carefully checked from both the operating and safety standpoints.

Before the installation, read the content of this manual **carefully**: it contains important information regarding product assembly and safety regulations.

The foundation

Our company was founded in 1963 by the Lorenzo, Luigi and Paolo Cuppone brothers. It immediately specialized in the production of ovens and equipment to prepare and cook pizza. The constant research and experimentation of new equipment that are even now the strength of our company, have led us to design and patent the machinery and ovens that have revolutionized the way pizza is made.

Technical service

Your Dealer can solve any technical problem regarding use and maintenance.

Do not hesitate to contact him in case of doubt.

CUPPONE since 1963

CUPPONE S.R.L.

Via Sile, 36

31057 Silea (TV) - ITALY

T +39 0422 361143

F +39 0422 360993

info@cuppone.com - www.cuppone.com

1 SAFETY INSTRUCTIONS	4
Safety instructions.....	5
Symbols used in the manual and on the labels applied to the machine.....	5
2 BASIC NOTIONS	6
Knowing your oven	6
Preparing to use the oven	6
Some piece of advice.....	7
Unsatisfactory cooking results.....	7
Cooking tables.....	8
3 USE	9
Knowing the control panel.....	9
Use guided procedure.....	10
4 MAINTENANCE AND CLEANING	12
Oven cleaning.....	12
Cleaning the chamber with the pyrolysis function.....	13
Replacing components.....	14
Oven downtime for prolonged periods	16
Disposal at end of life	16
Disposing of ashes and food residues	16
5 WARRANTY.....	17
6 SOMETHING IS NOT WORKING.... ..	18



1 SAFETY INSTRUCTIONS



- Read this guide carefully before using and maintaining the appliance, and keep it with care in an accessible place for any future consultation by the various operators.
- Moreover, the manual must always accompany the product through its life, even in case of transfer.
- Before performing any maintenance, disconnect the electricity supply.
- Unauthorised actions, tampering or modifications that do not follow the information provided in this manual can cause damages, injuries or fatal accidents and null and void the warranty.
- Use or maintenance that fail to comply with the instructions in this manual may cause damage, injury or fatal accidents.
- The serial plate provides important technical information. This is vital in case of a request for maintenance or repair of the equipment: please do not remove, damage or modify it.
- Some parts of the equipment can reach high temperatures. We recommend you avoid pressing surfaces and do not get materials either flammable or sensitive to heat near the appliance.
- Do not rest objects on the oven, above all if built in material sensitive to heat.
- These appliances are intended to be used for commercial applications, for example in restaurant kitchens, canteens, hospitals and commercial companies such as bakeries, butcher shops, etc., but not for the continuous and mass production of food. A use other than the stated one is considered improper, potentially dangerous for people and animals and might permanently damage the appliance. The improper use of the equipment shall void the warranty.
- This appliance can be used by children aged from 8 years and above and persons with reduced physical, sensory or mental capabilities or lack of experience and knowledge if they have been given supervision or instruction concerning the use of the appliance in a safe way and understand the hazard involved. Children must not play with the appliance. Cleaning and user maintenance shall not be made by children without supervision.
- To clean the appliance, any of its components or accessories and the sub-structure DO NOT use:
 - aggressive, abrasive, powder or corrosive detergents (e.g. hydrochloric or sulphuric acid, caustic soda, etc.).
 - abrasive or sharp tools (e.g. abrasive sponges, scrapers, steel brushes, etc.);
 - steamed or pressurised water jets.
- The staff using the appliance must be professionally prepared and periodically trained on its use, as well as the safety and accident prevention regulations.
- Children must be supervised to make sure they do not play with the appliance or parts of it.
- Always use tools resistant to heat (e.g. In steel). Cooking utensils in plastic or similar material might not withstand the oven high temperatures.
- Check regularly that fumes can be discharged safely. Do not obstruct the duct for any reason.
- FIRE RISK: leave the area around the appliance free and clean from fuels. Do not store flammable materials near this appliance.
- WARNING: RISK OF EXPLOSION! It is forbidden to use the oven in environments at risk of explosion.
- WARNING: always switch off the main switch when you finish using the appliance, above all during cleaning or in cases of prolonged downtime.
- If you notice any anomaly (e.g. damaged power cable, etc.), malfunction or fault, do not use the appliance and contact a Service Centre authorized by the Manufacturer. Demand original spare parts, or the Warranty will be null and void.
- Place the emergency phone numbers in a visible location.
- WARNING: it is forbidden to place flammable solids or liquids (spirits for instance) in the cooking chamber during operation.
- Monitor the appliance during its entire operation, do not leave dishes in the oven unattended!
- Failure to follow these regulations may cause damage or even fatal injury, subsequently invalidating the guarantee and relieving the Manufacturer of all liability.
- We recommend you have the appliance checked by an Authorized Service Centre at least once a year.

Safety instructions

- Noise levels lower than 70 dB.
- Do not disassemble, modify or disable machine parts (functional parts, control systems and safety devices).

Symbols used in the manual and on the labels applied to the machine



Indicates that caution is required when performing an operation described in a paragraph that bears this symbol. The symbol also indicates that maximum operator awareness is required in order to avoid unwanted or dangerous consequences.



Indicates that the surfaces marked with this symbol may be hot and must therefore be touched carefully.



Dangerous voltage



Risk of explosion



Reference to another chapter where the subject is dealt with in more detail.



Manufacturer's tip



Manufacturer's warning



Indicates that it is necessary to read carefully the paragraph marked with this symbol before installing, using and maintaining the equipment.

The company cannot be held liable for any print or transcription errors, reserving the right to make changes where deemed suitable without prior notice.

Partial reproduction without the Manufacturer's consent is prohibited. Measurements are purely indicative and not binding. The original language used to prepare this manual is English: the Manufacturer is not responsible for any translation/interpretation or print errors.



2 BASIC NOTIONS

Knowing your oven

► **Fig.1.**

Your oven can be used only to bake pizzas or similar dishes, such as bread or focaccia and to grill vegetables.

Its main parts are:

- A Oven door
- B Control panel
- C Panel to access electrical components
- D Technical room fan
- E Oven smoke exhaust
- F Circuit breaker (only USA models)

The oven can manage the temperature of the cooking chamber and separately the power of the top and bottom.

Preparing to use the oven

Clean the oven and any accessories accurately, both externally and internally, following the instructions in the dedicated chapter rigorously.

 **Maintenance and cleaning** - page 12.

On first start-up, set the temperature to **150 °C - 302 °F, MAX** at the top and **MIN** at the bottom for at least **8 hours without placing any food inside**. If a hood is fitted, we recommend it is kept ON. In this first phase, because of the humidity evaporating from the insulating materials, the oven will give out unpleasant smells and fumes that will gradually disappear during the following operating cycles.

 To switch the oven on and set its parameters, refer to:
Use - page 9

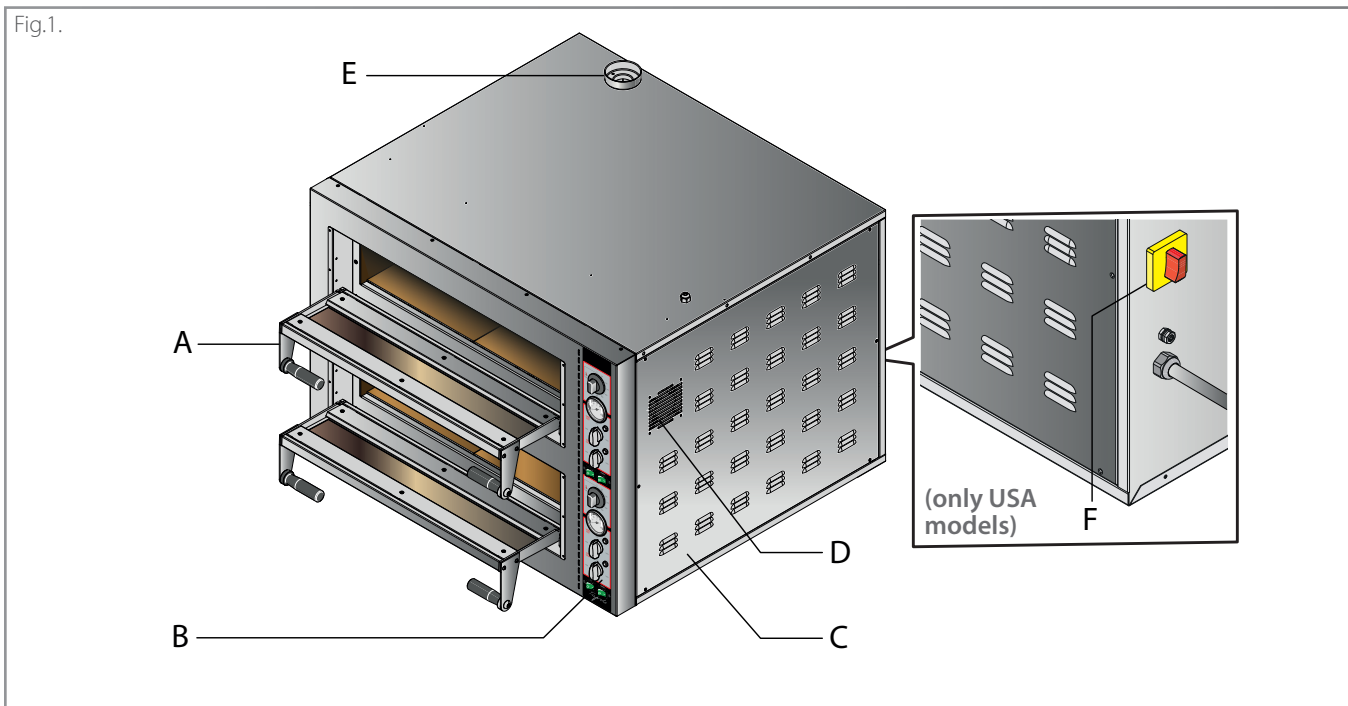

 **The first day of use is considered as a running-in period: during this time the refractory bricks and insulating material keep releasing humidity until they dry out completely.**

 **Some parts of the equipment can reach high temperatures. We advise you to avoid touching surfaces and not to get materials either flammable or sensitive to heat near the appliance. Do not rest objects on the oven, above all if built in material sensitive to heat. Take care and use personal protection equipment (i.e. gloves) when putting food into the cooking chamber or getting it out.**

Some piece of advice...

- Before starting cooking, always preheat the oven: this is vital to get good food. Pre-heating the oven **must last at least an hour.**
- During work, keep the refractory surfaces clean using a stiff bristle brush.
- Passing from a type of pizza to another, wait for the oven to stabilize.
- An excess of flour in the cooking chamber can create smoke, smell and give the pizza an unpleasant taste.
- Clean the oven at the end of service.
- For the pizza either in a tray or on a paddle, alternate the MIN/MAX selection during the pre-cooking and cooking phases (especially on the top) to obtain an optimal result and rapid heat recovery in the chamber.
- For bread, it is recommended to spray water on the surface of the product and place a pan of water in the oven to obtain steam in the chamber.

► Fig.2.

In the ovens, products cook thanks to the combined action of:

- **radiation:** the heat and infrared rays produced by the top elements make products crunchy and golden
 - this parameter is controlled by the TOP setting.
- **convection:** the hot air that circulates in the chamber cooks the product evenly
 - his parameter is controlled by the temperature setting in the chamber
- **conduction:** the bottom elements heat the refractory surfaces on which the products lie
 - this parameter is controlled by the BOTTOM setting.

UNSATISFACTORY COOKING RESULTS

If the cooking results are not as expected, try and check the following:

- **incorrect oven parameters:**
 - temperature in the chamber either too high or too low
 - settings of the BOTTOM or TOP either too high or too low
- **incorrect preheating:**
 - preheating is vital to get superb results right from the first pizza
 - during preheating, the BOTTOM temperature has been set too high: the refractory surfaces (without pizzas) have become too hot and burnt the first pizzas.

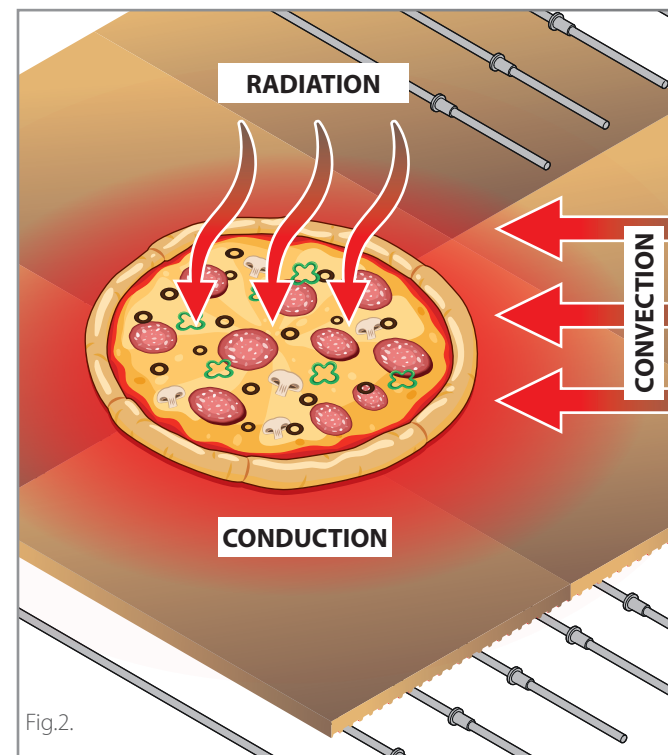

Fig.2.

WHAT IS PIZZAFORM?

Pizzaform is a Manufacturer's patent. It is a special press, produced in five models, to make pizza dough discs up to 52cm in diameter.

Its main features are:

- high hourly output, up to 400 pizzas an hour, without using specialized labour;
- consistent shape and thickness of the disc of dough, without giving up the traditional edge, obtained thanks to the special shape of the chrome plates;
- possibility of changing the thickness of the dough discs easily.



Basic notions

COOKING TABLES

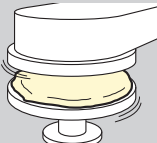

The parameters in the tables are just indicative, since they can vary according to the temperature of the room where the oven is installed and the type of dough to bake (e.g. type of flour, hydration, etc.).

		 Manual stretching				 Stretching with Pizzaform				Preheating for both types (Manual stretching or stretching with Pizzaform)
TYPE		COOKING				COOKING				
		TIME	TEMP.	TOP	BOTTOM	TIME	TEMP.	TOP	BOTTOM	
CLASSIC		3 min	320-330 °C 608-626 °F	MAX	OFF	2:30 min	320-330 °C 608-626 °F	MAX	OFF	time: 1 hour (it may vary according to the percentages set and according to the temperature of the room where the oven is installed) temperature or percentage: <ul style="list-style-type: none"> <u>Classic pizza</u>: preheating to 320-330 °C, MAX top OFF bottom, increasing according to the amount of work (e.g. switch immediately to MIN when starting to work continuously) <u>Neapolitan pizza</u>: preheating to 360/370 °C, MAX top, OFF bottom, increasing according to the amount of work (e.g. switch immediately to MIN when starting to work continuously) <u>Roman paddle pizza</u>: preheating to 280 °C, MAX top, MIN bottom, increasing according to the amount of work (e.g. switch immediately to MAX when starting to work continuously). <u>Pizzas in trays</u>: preheating to 280 °C, MAX top, MIN bottom, reversing the factors 5/10 minutes before starting to put the trays in the oven; carried out) <u>Bread</u>: preheating to 230 °C, MAX top, MIN bottom, immediately lowering to MIN as soon as the set temperature is reached, decreasing in the cooking phase (cooking with decreasing temperature).
PAN		5 min	280 °C 536 °F	MAX	MIN					
NEAPOLITAN		90 sec	360-370 °C 680-698 °F	MAX	OFF					
BAKING-TIN		7 - 8 min	280 °C 536 °F	MAX	MIN					
PADDLE	PRECOOKING	5 min	280 °C 536 °F	MAX	MIN					
	FINISHING	3 min	280 °C 536 °F	MAX	MIN					

Contents

Knowing the control panel	9
Use guided procedure	10
A - Turning the oven on.....	10
B - Setting the preheating.....	10
C - Starting cooking.....	11
D - Switching the light on (optional).....	11
E - Switching the oven off.....	11



Knowing the control panel ▶ Fig.3.

- Temperature knob**
Allows setting the chamber temperature
- Pyrometer**
Displays the temperature in the cooking chamber.
- White warning light**
If ON, it shows the top elements are heating
- Top power check**
Allows checking the power of the elements in the top, offering three adjustments:
 - OFF
 - MIN = 33%
 - MAX = 100%
- White warning light**
If ON, it shows the bottom elements are heating.
- Bottom power check**
Allows controlling the power of the elements in the bottom, offering three adjustments:
 - OFF
 - MIN = 33%
 - maximum (MAX = 100%)
- Light switch**
Switches the light in the cooking chamber on and off.
- ON/OFF switch**
Switches the oven on and off.

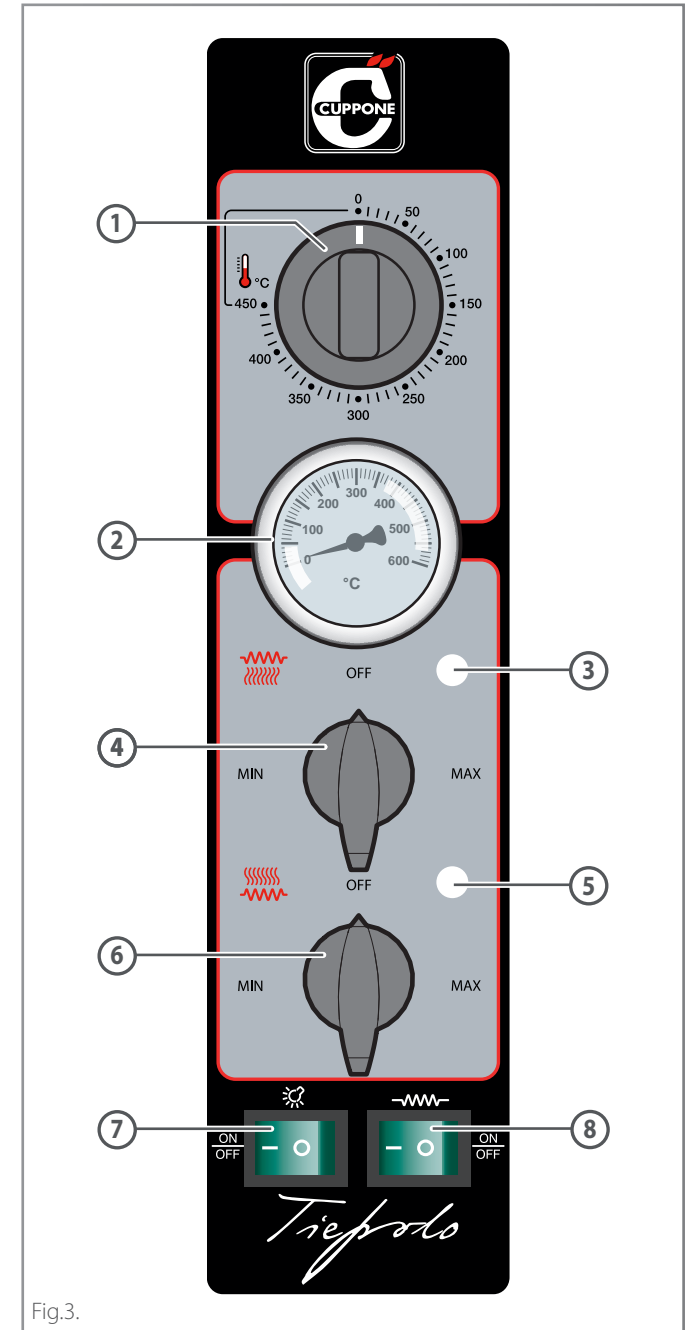

Fig.3.

Use guided procedure

A TURNING THE OVEN ON

► Fig.4.

Pressing the **ON/OFF** key powers the oven.

B SETTING THE PREHEATING

► Fig.5.

Rotate the **A** "chamber" temperature knob and the knobs **B** and **C** "top" and "bottom" power respectively to set the same cooking parameters as the recipe you wish to use (see table on page 8).

After the settings, the oven immediately begins to heat, however, it is necessary to wait about an hour before putting the products in the oven, so that the oven reaches an optimal temperature and is ready for cooking.

► Fig.6.

The white lights **D** and **E** will remain on until the set temperature is reached; their going off means that pre-heating is complete and the oven is ready for cooking.

The thermostat controlling the elements will keep the set temperature constant, switching the elements on and off as required.

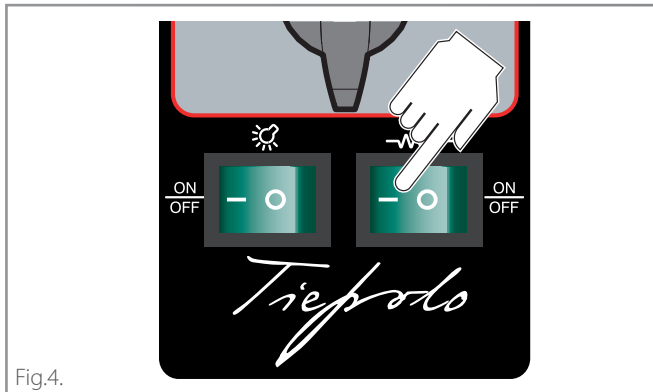

Fig.4.

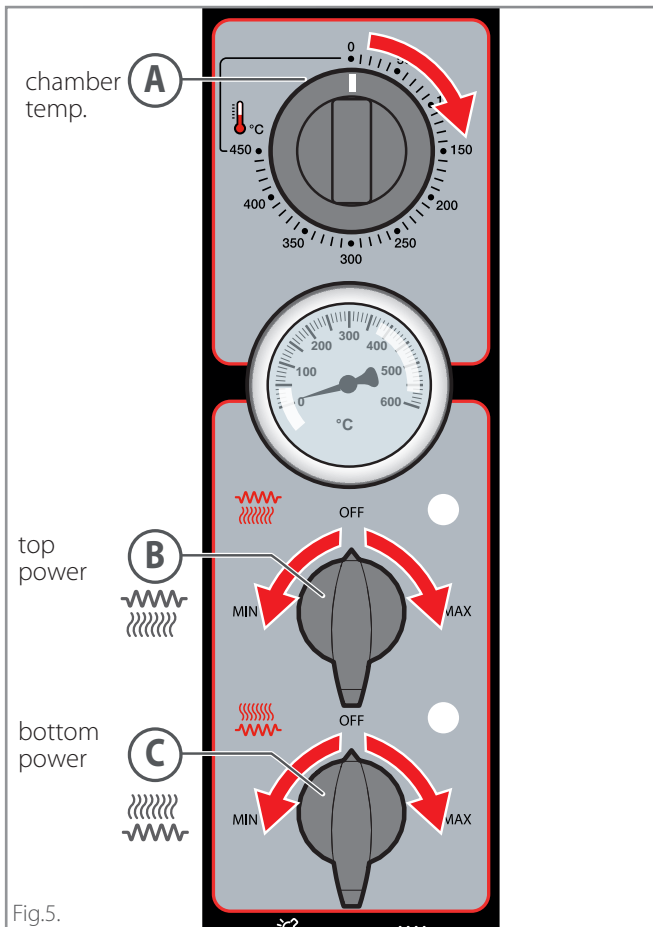

Fig.5.

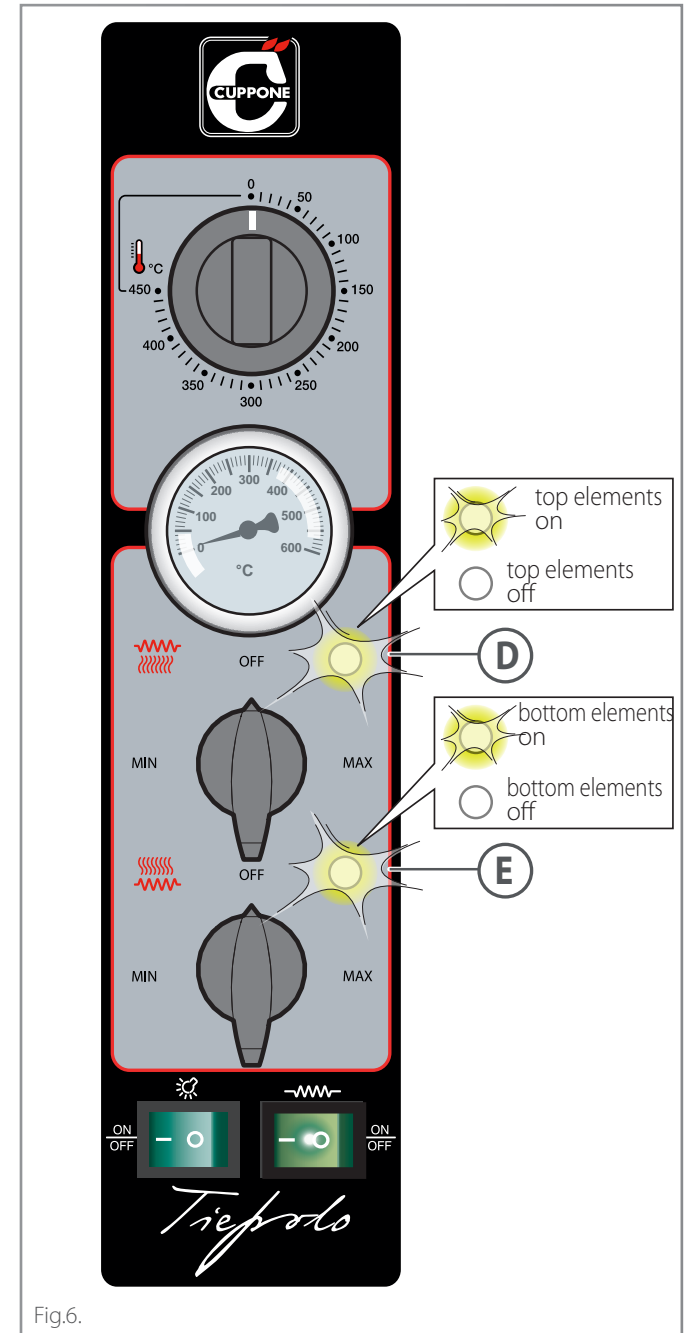

Fig.6.

C STARTING COOKING

► Fig.7.

Once preheating is complete, you can start cooking and bake the products using personal protection equipment (e.g. gloves) and tools suitable for contact with food and made of material resistant to high temperatures (e.g. steel).



For optimal results, always adhere to the oven capacity declared by the Manufacturer and position the products to be cooked evenly in the cooking chamber.

During cooking, it is always possible to change the temperature or the top and bottom power acting as usual.

D SWITCHING THE LIGHT ON (OPTIONAL)

► Fig.8.

With the oven both off and on, the light can be switched on pressing the **LIGHT** key, as required. Press the same key to switch it off.

E SWITCHING THE OVEN OFF

► Fig.9.

To switch the oven off, press the **ON/OFF** key.

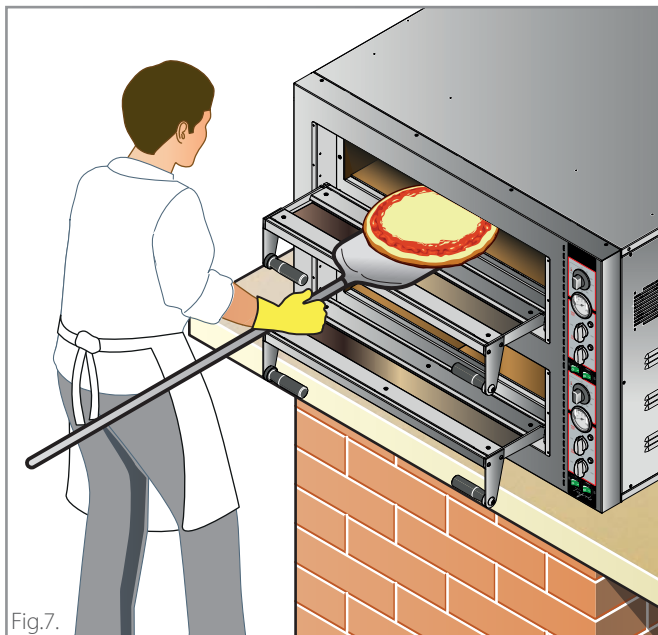

Fig.7.

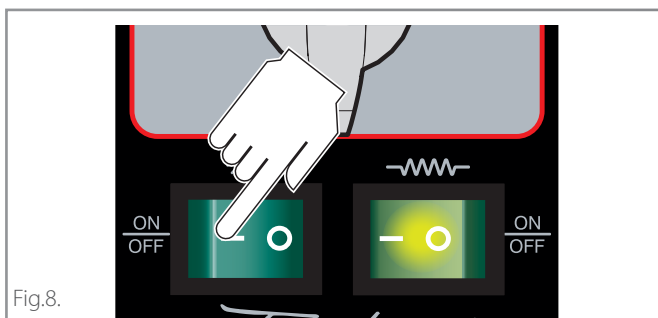

Fig.8.

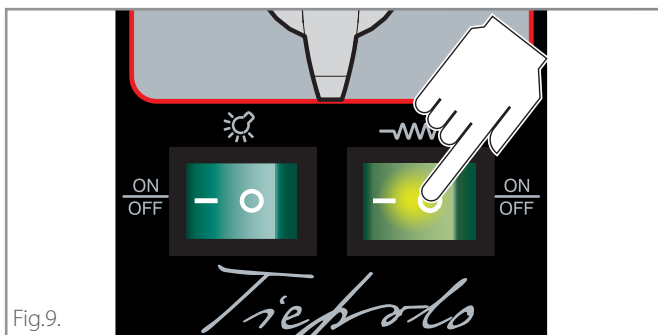



Fig.9.

4 MAINTENANCE AND CLEANING

Warnings

 Before any cleaning, it is necessary to **switch off the power** to the appliance (acting on the system switch) and wear suitable personal protection equipment (e.g. gloves, etc.). The user must carry out only routine maintenance, for extraordinary maintenance, contact a Service Centre requesting service from an authorised technician. The Manufacturer warranty does not cover damages due to negligent or incorrect maintenance or cleaning (e.g. use of unsuitable detergents).

 **Any cleaning must be carried out with the oven completely cold and wearing adequate personal protection devices (e.g. gloves, etc.).**

When cleaning any part or accessory do NOT use:

- abrasive or powder detergents;
- aggressive or corrosive detergents (e.g. hydrochloric or sulphuric acid, caustic soda, etc.). Caution! Never use these substances also when cleaning the substructure/floor under the appliance or its base;
- abrasive or sharp tools (e.g. abrasive sponges, scrapers, steel brushes, etc.);
- steamed or pressurised water jets.

 *It is best to have a Service Centre perform maintenance and inspection on the appliance at least once a year to ensure top working and safety conditions.*

Keep the vents of the electrical compartment clean and clear.

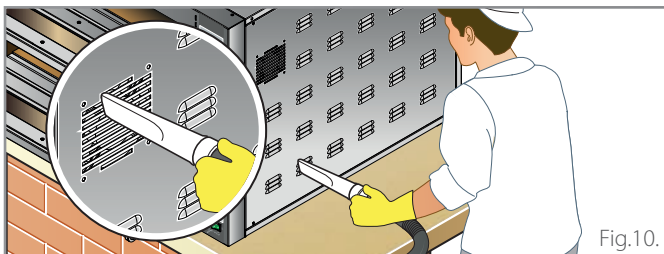

Oven cleaning

CLEANING THE EXTERNAL STEEL PARTS

Use a cloth dampened with hot soapy water and end with rinsing and drying.

CLEANING THE GLASS

Clean any glass with a soft cloth and special glass detergent.

CLEANING THE CONTROL PANEL

Clean the control panel with a soft cloth and a little detergent for delicate surfaces.

Avoid also using very aggressive detergents that may damage the construction material (polycarbonate).

CLEANING THE REFRACTORY SURFACE

On the refractory surface, there are normally some food residues (e.g. fat, food residues, etc.) that must be removed frequently for health and safety reasons.

Remove the coarser food residues with a natural fibre brush; then, if necessary, remove the refractory bricks of the cooking surface as shown in the figure and suck the carbonized residues accumulated under them on the bottom of the oven with an ash extraction bin.

Never use liquids to clean the refractory surface.

 **While reinserting the bricks, be careful not to pinch your fingers.**

 *Replacement refractory bricks can be obtained from the Manufacturer.*

If manual cleaning is not enough, use the **PYROLYSIS** ► function, see page [13](#).

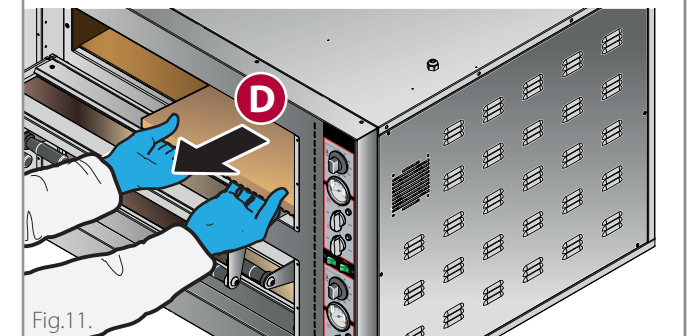
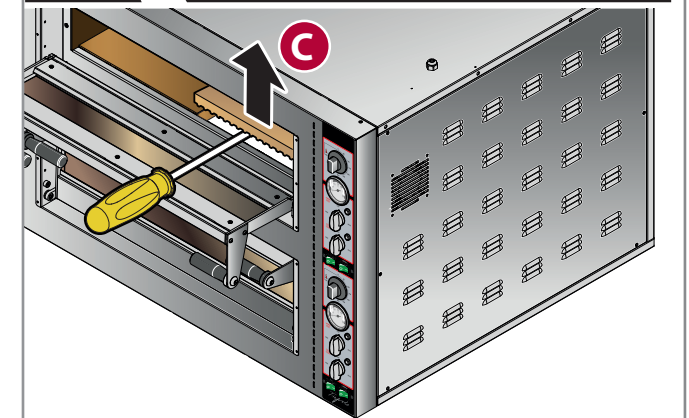
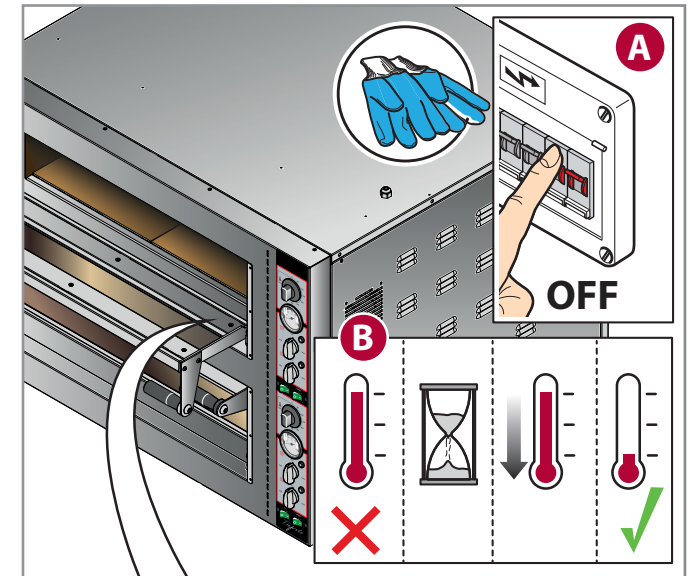

Fig.11.

CLEANING THE CHAMBER WITH THE PYROLYSIS FUNCTION

Pyrolysis is a thermochemical crystallization process of food residues that have deposited in the cooking chamber, which takes place by bringing the oven up to 400 °C/752 °F.

! Before starting the pyrolysis, remove the coarser food residues with a natural fibre brush.

► Fig.12.

- Rotate the **A** "chamber" temperature knob clockwise to set a temperature of 400 °C /752 °F;
- set the **top power** to **MAX**;
- set the **bottom power** to **MAX**;
- switch the lights in the cooking chamber off.

► Fig.13.

When the set temperature is reached, switch the oven off using the **ON/OFF** key and let it cool with the door closed.

► Fig.14.

With a cold oven, clean the chamber from the crystallized food residues using a natural fibre brush and then vacuum with an ash extraction bin.

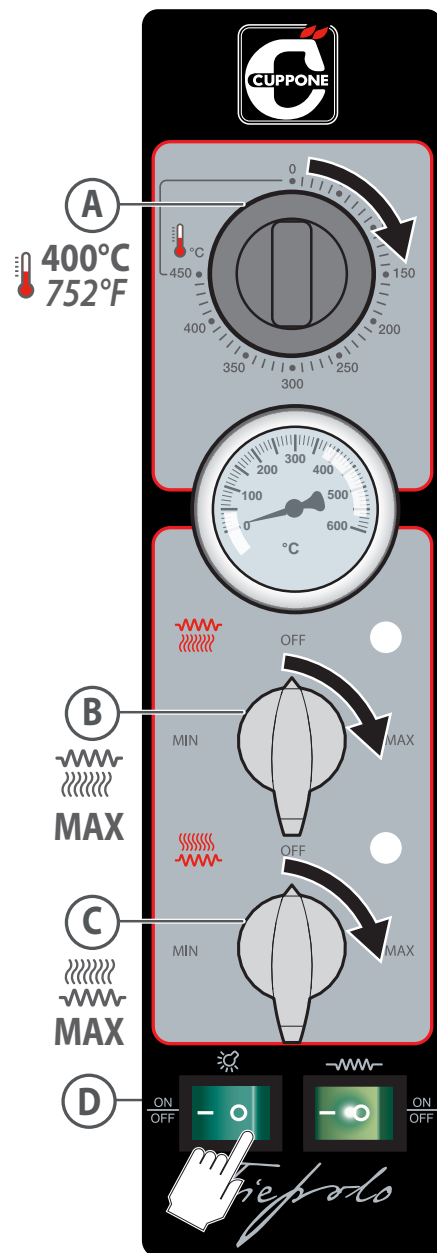

Fig.12.

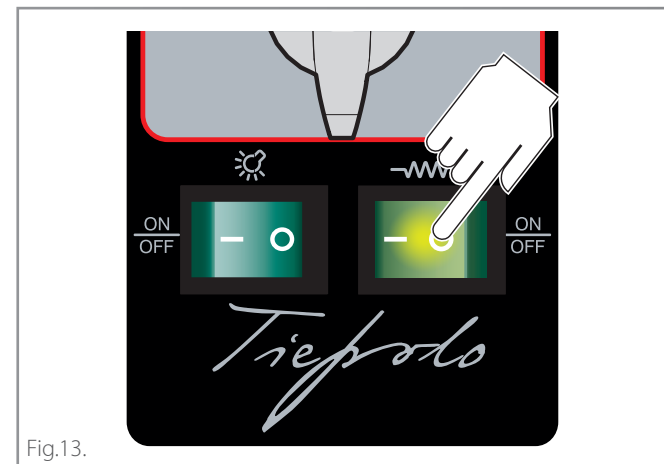

Fig.13.



Fig.14.

Replacing components

⚠ The user must replace only the stated components: in case of a fault or for extraordinary maintenance, contact the Dealer, requesting service from an authorised technician.

⚠ As replacements, always use original spare parts to be requested from the Manufacturer: using non original parts might cause injuries to people, non optimal performance and even serious damage to the appliance itself.

⚠ Before carrying out any replacement work, it is necessary to disconnect the power supply of the appliance (by acting on the system switch).

⚠ Any replacement must be carried out with the oven completely cold and wearing adequate personal protection devices (e.g. gloves, etc.).

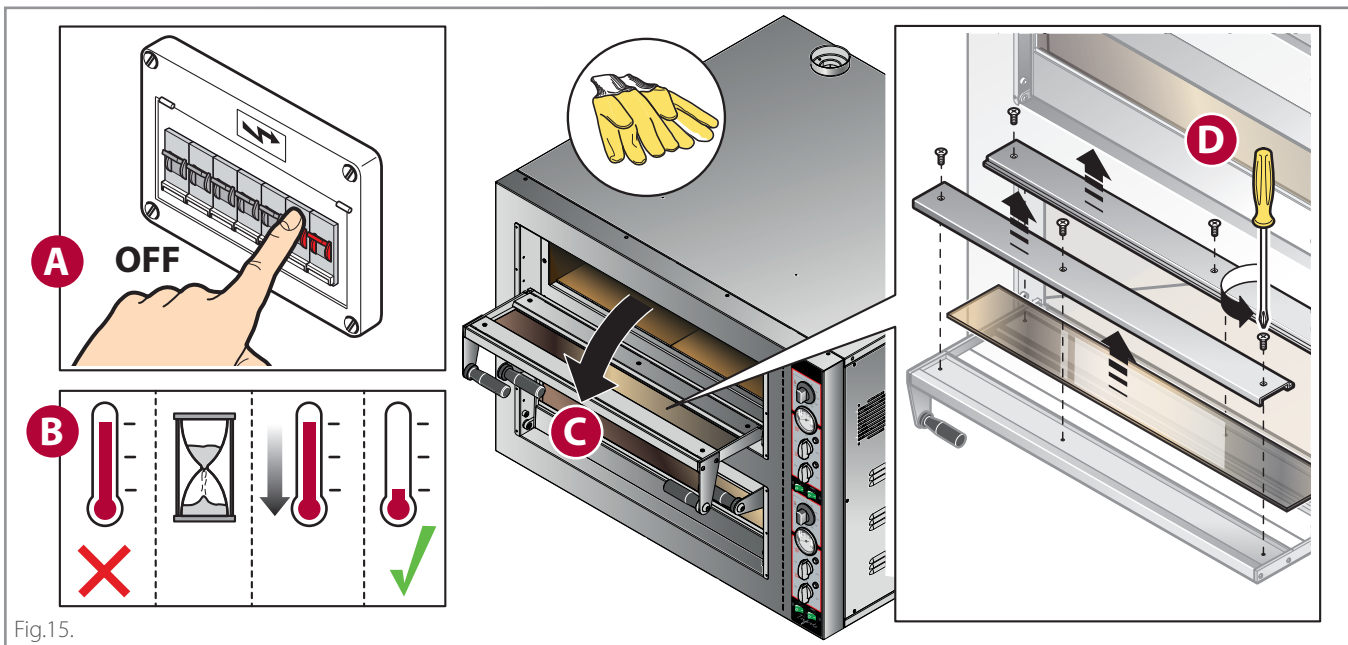

Fig.15.

REPLACING THE DOOR GLASS

► Fig.15.

REPLACING THE INTERNAL BULB AND GLASS

► Fig.16.

Before replacing the bulb, **switch off the power** to the appliance (acting on the system switch); it is not enough to use the **ON/OFF** key, because bulbs can still be live.

Never press the bulb glass with your bare hands; always wear gloves.

Never switch the oven on without having refitted the bulb protective glass; replace it straight away if it breaks.

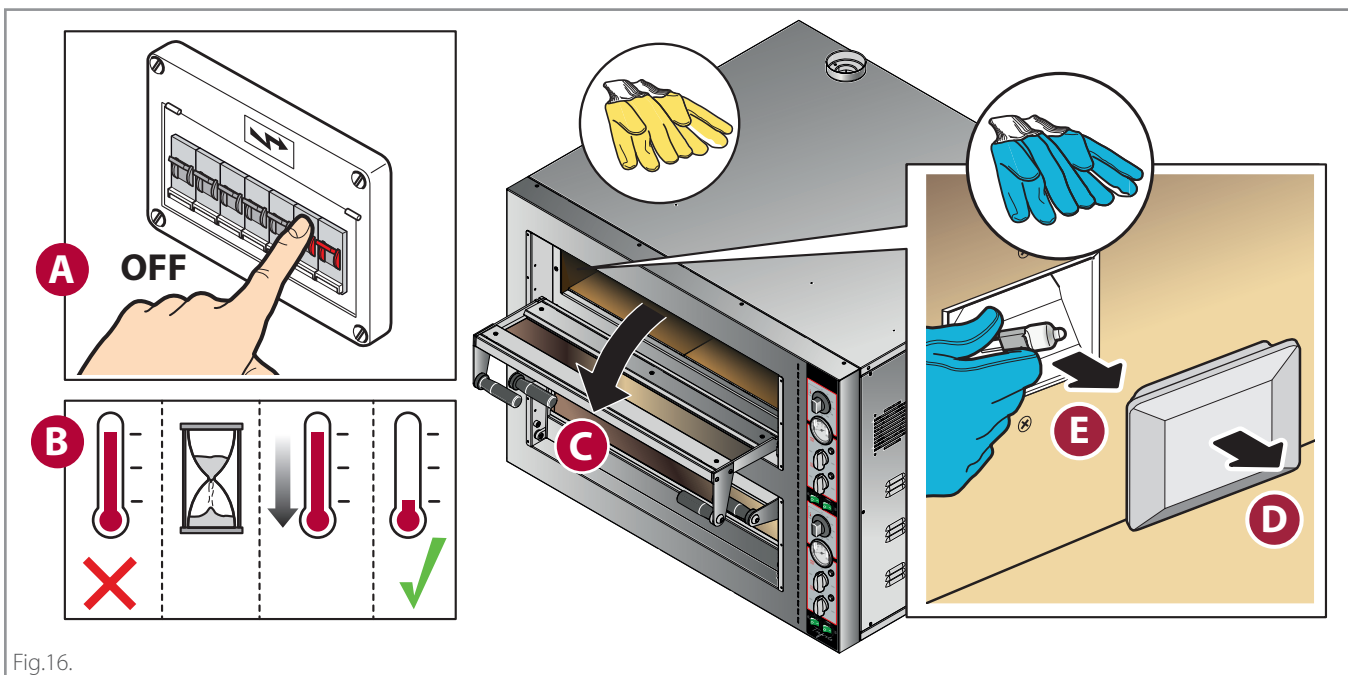

Fig.16.

REPLACING THE REFRACTORY BRICKS

► Fig.17.

REPLACING THE DOOR HANDLE

► Fig.18.

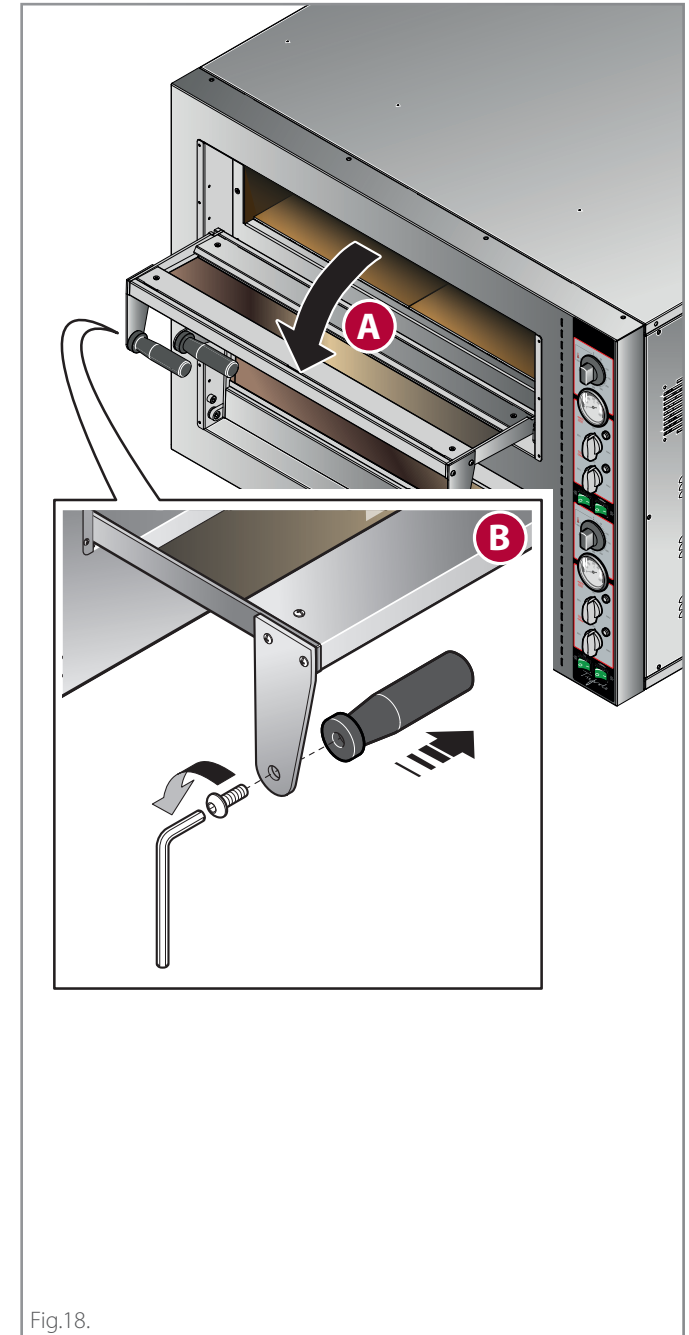
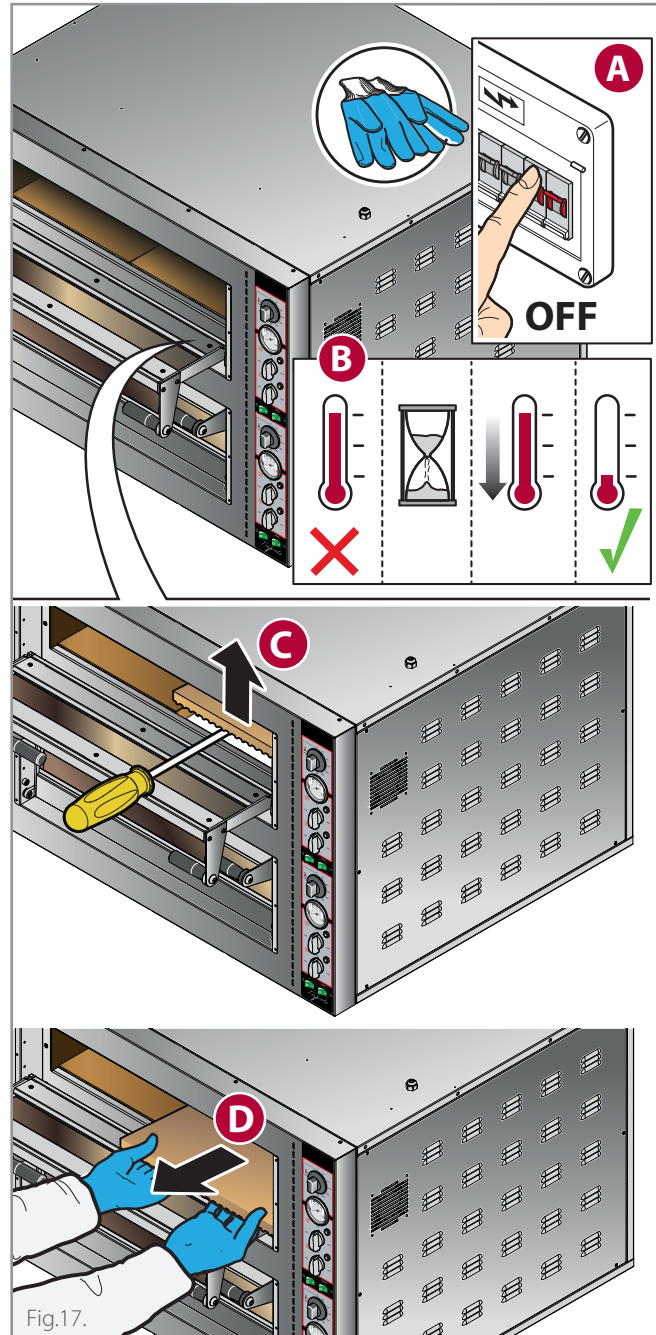

Oven downtime for prolonged periods

During any downtime, switch the power off. Protect the steel outside surfaces passing over them with a soft cloth slightly damp with Vaseline oil.

Leave the door ajar to guarantee correct ventilation.

Before resuming operations:

- accurately clean the equipment and accessories;
- reconnect the equipment to the power;
- inspect the equipment before using it.

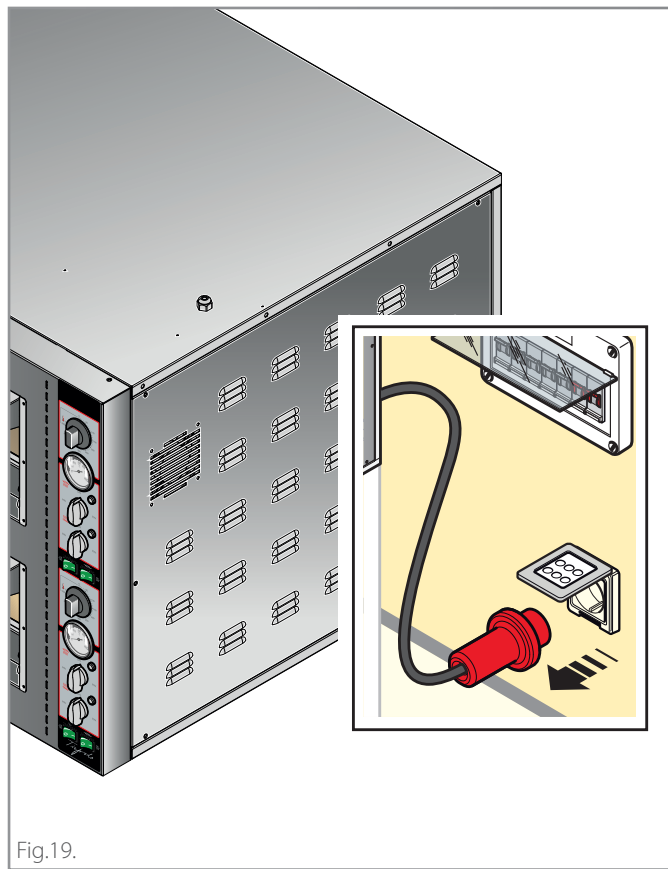



Fig.19.

Disposal at end of life

 **Before disposing of the equipment, cut or remove the power cord, with the appliance disconnected from the power supply, to avoid any unauthorized use and the risks associated with it.**

 **Block the door opening (for example with adhesive tape or clips) so that no child can accidentally be trapped inside the cooking chamber while playing.**



Pursuant to art. 13 of Legislative Decree no. 49 of 2014 "Implementation of WEEE directive 2012/19/EU on electric and electronic waste", the barred bin symbol specifies that the product was introduced on the market after August 13, 2005 and that it must not be discarded with other waste at the end of its working life but disposed of separately. All the equipment has been made with recyclable metal materials (stainless steel, iron, aluminium, zinc plate, copper, etc.) that as a percentage make up more than 90% of the weight. Attention must be paid to the management of this product at the end of its life, reducing any negative impact on the environment and improving the efficiency of resources, applying the principles of "who pollutes pays", prevention, preparation for re-use, recycling and recovery. Please remember that illicit or incorrect product disposal is punishable by law.

Information on disposal in Italy

WEEE equipment in Italy must be delivered to:

- to Collection Centres (also named eco-islands or eco-platforms)
- the dealer where new equipment is purchased who must withdraw it free of charge ("one to one" withdrawal).

Information on disposal in European Union countries

The EU Directives on WEEE equipment has been adopted in different ways by different countries, therefore in order to dispose of this equipment correctly we suggest that you contact your local authority or your dealer in order to ask the correct method of disposal.

Disposing of ashes and food residues

 **The ash and food residues removed with cleaning must be disposed of according to the regulations in force in the country where the oven is used.**

If in doubt, we suggest contacting the local authorities to ask for the correct method of disposal.

While waiting for disposal, the ash and food residues must be stored in fireproof metal cans, resistant to high temperatures and provided with a lid that must always remain closed.

Keep the latter away from the elements and in a place inaccessible to children and animals.

Do not approach materials that can be flammable, explosive or heat-sensitive.

Warranty conditions

- 8.1 Each product sold is to be considered compliant when delivered in the quantity, quality and type indicated in the written Confirmation, please refer to the provisions of art. 1.2.
- 8.2 The Seller guarantees:
 - (a) that the Products are free from defects in materials or workmanship, and
 - (b) that (excluding the case of known defects or which should have been known by the Buyer) the Products are of marketable quality.
- 8.3 Any hidden defects in the Products must be reported in writing by the Buyer within 8 days of discovery, under penalty of forfeiture. Packaging defects - even if they have caused defects or damage to the internal product - which had to be reported at the time of delivery, are excluded pursuant to art. 5.8.
- The defect report must contain the specific indication of the defective Products, a detailed description of the type of defect that the Product has, as well as the delivery date and that of discovery.
- The warranty is excluded if the defect derives from the Purchaser's actions such as, by way of example, incorrect installation of the Product, use of the Product in a manner that does not comply with the normal method of use, failure to comply with the instructions contained in the use and installation manual, tampering with the Product. The warranty does not cover normal wear and tear of the Product due to use.
- The Seller is responsible for defects that occur within one year from the activation of the warranty as provided for in point 8.12.
- 8.4 the Seller will have the right to examine, or have a representative examine, the Product and, if this shows the existence of the defect, the Buyer will be entitled to a repair or replacement, at the Seller's sole discretion.
- It is understood that, once the defect has been reported, the Buyer must not use the Product until it is viewed by the Seller or its representative. In the event that the Seller realizes that the Product has been used after the complaint, the Buyer loses the right to obtain a replacement or repair.
- 8.5 Replacement or repair will take place under the following terms:
 - a) The Seller may repair the defective Products by going - or sending a representative - to the place where such Products are located;
 - b) Alternatively, the Seller may repair the defective Product at its own factory, or other place chosen by the Seller,

- c) Alternatively, the Seller may opt for the replacement of the defective Products;
- In the event that the repair / replacement is not possible, the Seller will pay the Buyer a refund to be quantified, a refund which, however, must not exceed the price paid. Compensation for damage is excluded.
- 8.6. In case of repair of the Product at a place chosen by the Seller or in case of replacement of the defective Product, the shipment of the Product will be borne by the Buyer who must send it, at its own expense and risk, to the place stated by the Seller.
- 8.7 In no case will the Seller be liable for indirect or consequential damages and/or for loss of profits that the Buyer may suffer as a result of defects in the products such as (but not limited to) cancellation of orders by customers, penalties for delayed deliveries, penalties or refunds of any kind.
- 8.8 The Seller shall indemnify the Buyer from any liability or damage arising from defective Products, unless such liability derives from the Buyer's negligent acts or omissions or from the latter's non-fulfilment of its obligations.
- 8.9 The Seller is not liable for damage to persons and/or property that may derive from the improper use of the Products and/or from any use, processing or transformation of the Products that do not comply with their intended use and/or the instructions provided by the Seller. Save the hypothesis of gross negligence or wilful misconduct by the Seller.
- The Seller will also not be liable in the event of damage to property or injury to people or in the case of malfunction or damage or deterioration of the Product deriving from the fact that the Product has been connected to a non-compliant electrical system.
- 8.10 The Buyer will not be able to raise any claim for injury to people or damage to property other than those which are the subject of the contract, or for loss of profit, unless it results from the circumstances of the case that the Seller has committed "gross negligence".
- 8.11 "Gross negligence" does not include any and all lack of adequate care and expertise, but means an act or omission by the Seller which implies either a failure to take into consideration those serious consequences that a conscientious supplier would normally have foreseen as probably occurring, or a deliberate neglect of any consequence deriving from such act or omission.
- 8.12 The effect of the warranty referred to in this article is subject to its activation to be carried out through the website www.cup-pone.com within 48 hours after the time the Product is installed.

Spare parts

- 9.1 For 10 years from delivery of the Product, the Seller undertakes, at the request of the Buyer, to assist him in identifying spare parts for product maintenance. In any case, the Seller is in no way responsible for the failure to identify such sources.

Applicable law and multi-step clause

- 11.1 Italian law, as the Seller's law, will govern sales made on the basis of these General Conditions.
- 11.2 The Parties exclude the application of the Vienna Convention.
- 11.3 The parties will submit any disputes arising from sales made on the basis of these General Conditions to the conciliation attempt provided for by the Conciliation Service of the Milan Arbitration Chamber. In the event that the attempt fails, any disputes, even of a non-contractual nature, deriving from sales made on the basis of these General Conditions, will be resolved by arbitration according to the Rules of the Milan Arbitration Chamber, by a single arbitrator/three arbitrators, appointed in compliance with this Regulation. The Arbitration Tribunal will judge according to Italian law. The seat of the arbitration will be in Milan (Italy). The language of the arbitration will be Italian.

6 SOMETHING IS NOT WORKING...

What to do in case of any malfunction

- Try and check the table on this page. If none of the proposed solutions solves the problem, continue reading the following procedure.

- Note the oven data (rating plate) and the date and number of the appliance purchase invoice.

Serial number.....

Model.....

Invoice date.....

Invoice number.....

- Read the chapter on warranty carefully.

 **WARRANTY** - page 17.

- Contact the Dealer with the details of the oven. While waiting for Technical service, disconnect the appliance from the mains.

CUPPONE since 1963
 CUPPONE S.R.L.
 Via Sile, 36
 31057 Silea (TV) - ITALY
 T +39 0422 361143
 F +39 0422 360993
 info@cuppone.com - www.cuppone.com

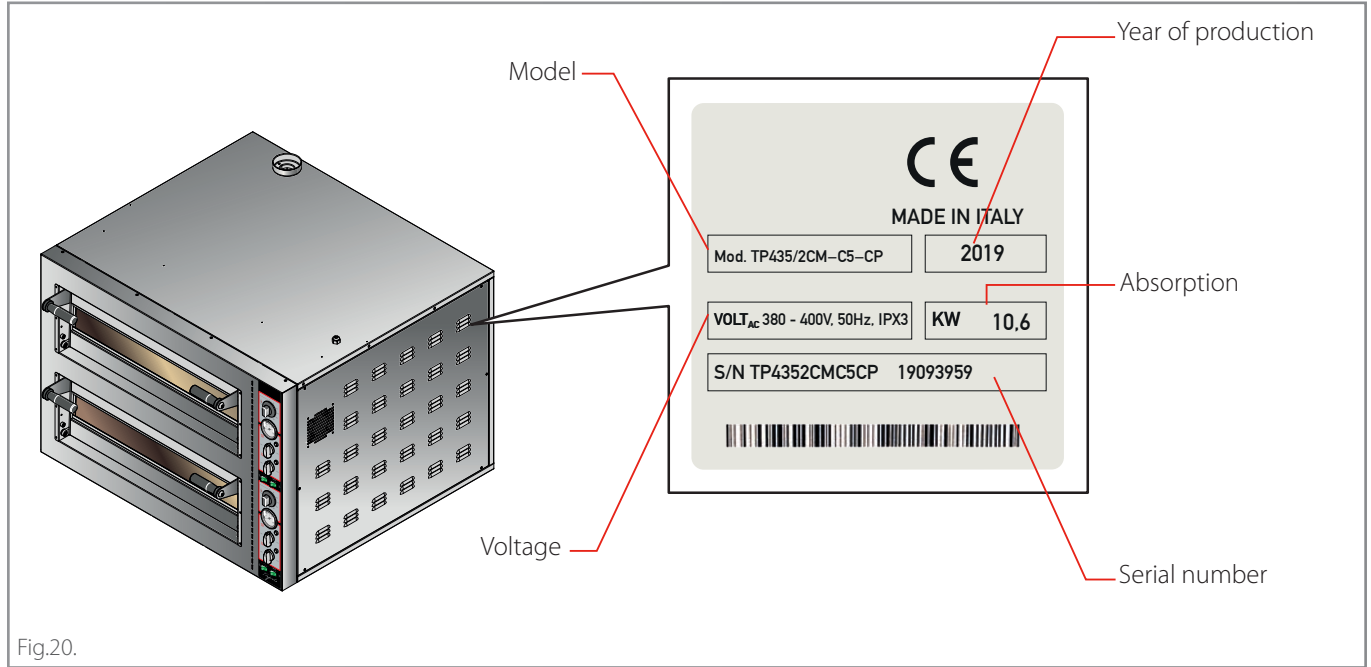

Fig.20.

Problem	Solution
The oven does not turn on	<ul style="list-style-type: none"> • Make sure the oven is correctly connected to the mains (plug correctly inserted into the socket) and that the mains are working. • Make sure the main switch is ON.
The oven turns on but cooking does not start	<ul style="list-style-type: none"> • Make sure you set the cooking parameters correctly.
The oven does not cook evenly	<ul style="list-style-type: none"> • Make sure you set the cooking parameters correctly. • In case of incomplete baking cycles, change the positions of the pizzas.
The first pizzas are burnt	<ul style="list-style-type: none"> • During preheating, the BOTTOM power has been set too high: the refractory surfaces (without pizzas) have become too hot and burnt the first pizzas.





CUPPONE since 1963

CUPPONE S.R.L.

Via Sile, 36

31057 Silea (TV) - ITALY

T +39 0422 361143

F +39 0422 360993

info@cuppone.com - www.cuppone.com

