

# Retail scale SC II System Class II

## Operating instructions

as from program version 1.29 (with CD)

61429850113 en-US



**Bizerba Service**  
**www.bizerba.com**

© 04 / 2016

Alle Rechte vorbehalten  
All rights reserved  
Tous droits réservés  
Reservados todos los derechos  
Tutti i diritti riservati

Bizerba GmbH & Co. KG,  
72336 Balingen

Postfach 10 01 64  
72301 Balingen, Germany  
Telephone (+49 7433) 12-0, Fax (+49 7433) 12-2696  
E-mail: [marketing@bizerba.com](mailto:marketing@bizerba.com)  
Internet: [www.bizerba.com](http://www.bizerba.com)

# Table of Contents

<b>1</b>	<b>About these instructions .....</b>	<b>7</b>
1.1	Safe-keeping .....	7
1.2	Target group .....	7
1.3	Symbols used .....	7
1.4	Warnings .....	8
<b>2</b>	<b>About the device.....</b>	<b>10</b>
2.1	Device types .....	10
2.2	Accessories.....	10
2.3	Intended use .....	10
2.4	Identification plate .....	10
2.5	Verification information .....	11
2.5.1	Software ID, update logbook.....	12
2.6	Standards and directives .....	13
2.7	Operating conditions .....	14
2.7.1	Power supply .....	15
2.7.2	Wireless LAN device network .....	16
2.8	Warranty .....	16
2.9	Demo license .....	17
2.10	Software by third party .....	17
2.11	Disposal of devices/environmental protection .....	17
<b>3</b>	<b>Safety instructions .....</b>	<b>18</b>
3.1	System-related sources of hazards .....	18
3.2	Requirements for operating personnel.....	19
<b>4</b>	<b>Installation.....</b>	<b>20</b>
4.1	Transport and storage.....	20
4.2	Start-up .....	20
4.2.1	Switching device on .....	20
4.3	Decommissioning.....	20
4.4	Setting the display.....	20
4.5	Installation and assembly.....	21
4.5.1	Assembling the device .....	21
4.5.2	Leveling.....	21
4.5.3	Check the electric connection .....	21
4.5.4	Cable connections .....	22
4.5.5	Rechargeable battery.....	23
<b>5</b>	<b>Device and operating controls .....</b>	<b>25</b>
5.1	Main switch .....	25
5.2	Display .....	25
5.2.1	Display icons.....	25

5.3	Keyboard.....	26
5.3.1	Membrane keyboard.....	27
5.3.2	Tactile keyboard.....	28
5.3.3	Key functions .....	28
5.4	Printer .....	30
5.4.1	Printer lid and side cover for SC II 100/200 .....	30
5.4.2	Opening and closing the thermal print head .....	33
5.4.3	Label printer .....	34
5.4.4	Ticket roll.....	35
5.4.5	Paper feed .....	37
<b>6</b>	<b>Operation.....</b>	<b>40</b>
6.1	Switching device on .....	40
6.2	Switch off device .....	41
6.3	Resetting the device .....	41
6.4	Correction options.....	41
6.4.1	Canceling function .....	41
6.4.2	Deleting characters.....	41
6.5	SC II 100 K/B .....	41
6.5.1	Switching device on .....	42
6.5.2	SC II 100 K/B operation with weight value.....	42
6.6	PLU call-up .....	43
6.6.1	Direct PLU call-up.....	43
6.6.2	Indirect PLU call-up.....	43
6.6.3	Calling PLUs after switch-over.....	44
6.6.4	PLU call-up without PLU text .....	44
6.6.5	PLU call-up with automatic PLU prefix.....	44
6.7	Operating procedure after PLU call-up .....	45
6.7.1	PLU call-up and registration.....	45
6.7.2	Unit price input after PLU call-up .....	45
6.7.3	Register with unit price or selling price = 0. ....	46
6.7.4	Registering manual weight input (depending on country).....	46
6.7.5	Multiplication of PLU piece-price article with predefined quantity .....	46
6.7.6	Multiplication of PLU price per piece with a partial number of pieces.....	47
6.8	Operation procedure without PLU call-up .....	47
6.9	Product group sale by PLU .....	49
6.10	Constant.....	49
6.11	Scroll function .....	50
6.12	Cancellation .....	50
6.13	Displaying subtotal.....	51
6.14	Total .....	52
6.15	Tare.....	52
6.15.1	Tare balancing for unknown tare values .....	52
6.15.2	Tare balancing with known tare .....	53
6.15.3	PLU tare.....	54
6.16	Normal ticket.....	55

6.17	Assisted sale with labels .....	56
6.18	Article with fixed volume and fixed price .....	56
6.19	PLU with data of origin .....	57
6.19.1	Sale with manual input of abbreviated traceability number.....	57
6.19.2	Sale with abbreviated traceability number from configuration .....	59
6.20	Self-service mode .....	60
6.21	Cash register functions .....	61
6.22	Sale of articles with different price types.....	62
6.22.1	n*quantity grad.....	63
6.22.2	n*amount grad. ....	63
6.22.3	Percent graduation.....	64
6.22.4	Amount graduation.....	64
6.22.5	Mix. special price .....	65
6.23	Obligatory input for piece price for piece-price articles .....	66
6.23.1	Mandatory entry per PLU.....	66
6.23.2	Obligatory input always .....	66
6.23.3	Obligatory input limited .....	67
6.24	Input of number of bags obligatory .....	67
6.25	Sale with weight-fixed-price article.....	68
6.25.1	PLU type: "Manual-weighed" .....	68
6.25.2	PLU type: "By-count weighed" .....	69
6.25.3	PLU type: "Manual fixed weight" .....	70
6.25.4	PLU type:"By-count fixed weight" .....	71
6.26	PLU type: "By count".....	71
6.26.1	Mandatory input for By-count.....	75
6.27	Date / time.....	75
<b>7</b>	<b>Troubleshooting .....</b>	<b>76</b>
7.1	Fault description.....	76
7.2	Messages.....	76
<b>8</b>	<b>Maintenance.....</b>	<b>88</b>
8.1	Cleaning.....	88
8.1.1	Cleaning device .....	88
8.1.2	Cleaning the printer.....	88
8.1.3	Cleaning products for printer.....	90
8.2	Maintenance .....	92
8.2.1	Testing the weight display.....	92
8.2.2	Note on storing thermal paper .....	93
8.2.3	Ticket, label and linerless rollers.....	93
<b>9</b>	<b>Technical data.....</b>	<b>94</b>
9.1	Dimensions .....	94
9.2	Power supply .....	94
9.3	Ambient conditions.....	95

---

	<b>Subject index .....</b>	<b>96</b>
<b>10</b>	<b>Annexe.....</b>	<b>99</b>
	declaration of conformity SCII.....	100
	EU declaration of conformity SC II.....	101
10.1	WLAN_BWLC2 .....	102
10.2	Sparklan_WUBR-508N .....	106

# 1 About these instructions

Read the operating instructions carefully before connecting and switching on the device so that you can make most of the device's quality and possible applications.

These operating instructions explain how to operate and set the device.

It also includes functions that are only required by Bizerba Service. Contact your Bizerba specialist if necessary.

Bizerba products undergo continuous further development and are subject to different country-specific regulations. Examples of pictures and graphics included in these instructions may vary from the version you have received.

## 1.1 Safe-keeping

These operating instructions are an integral part of the device and must be kept next to it, easily accessible for all personnel.

When selling this device, these operating instructions have to be attached in their entirety.



## 1.2 Target group

The device must be operated by trained personnel only. This means that the operator has to be familiar with the contents of these operating instructions.

Installation, maintenance and repairs must be performed by Bizerba authorized specialists only.

## 1.3 Symbols used

Various symbols are used in these instructions.

Symbol	Description
	Text with arrow prompts you to carry out an action.
	A key symbol prompts you to press this key.
<Key>	Text within < > refers to a key.
<Key> + <key>	Key combination. Press and hold first key, press second key.
"Display"	Text within " " shows the display text.
①	Item number in figure.

### Information



Additional information for better understanding.

### Instructions



These instructions must be strictly observed.

## Menu settings

Menu settings required for a function are marked in grey.



### Menu setting

- Setting of the menu.  
Select **2 2 1**: Key sequence for selection of menu. Starting point is the main menu.

## 1.4 Warnings

Warnings are divided into danger levels by the signal word above the warning symbol.

Structure of warnings and meaning of signal words are described in these instructions as follows.

	<p><b>⚠ DANGER</b></p> <p><b>Source of danger with high risk of imminent danger to persons!</b>  <b>The consequences are:</b>  <b>life threatening injuries,</b>  <b>serious health damage</b></p> <ul style="list-style-type: none"> <li>– Measurements for prevention of danger are specified.</li> </ul>
	<p><b>⚠ WARNING</b></p> <p><b>Source of danger with medium risk of possible danger to persons!</b>  <b>The consequences can be:</b>  <b>serious injuries,</b>  <b>damage to health,</b>  <b>serious damage to property</b></p> <ul style="list-style-type: none"> <li>– Measurements for prevention of danger are specified.</li> </ul>
	<p><b>⚠ CAUTION</b></p> <p><b>Source of danger with low risk of possible danger to persons!</b>  <b>The consequences can be:</b>  <b>injuries,</b>  <b>damage to property.</b></p> <ul style="list-style-type: none"> <li>– Measurements for prevention of danger are specified.</li> </ul>



	<p data-bbox="507 185 647 226"><b>NOTICE</b></p> <p data-bbox="480 271 975 309"><b>Source of danger, improper use!</b></p> <p data-bbox="480 315 954 353"><b>Damage to property can result.</b></p> <ul data-bbox="491 365 1286 403" style="list-style-type: none"><li data-bbox="491 365 1286 403">– Measurements for prevention of danger are specified.</li></ul>
--	--

## 2 About the device

### 2.1 Device types

The SC II is available with either linerless or label printer.  
The SC II 7" is equipped with a TFT 7" customer display.

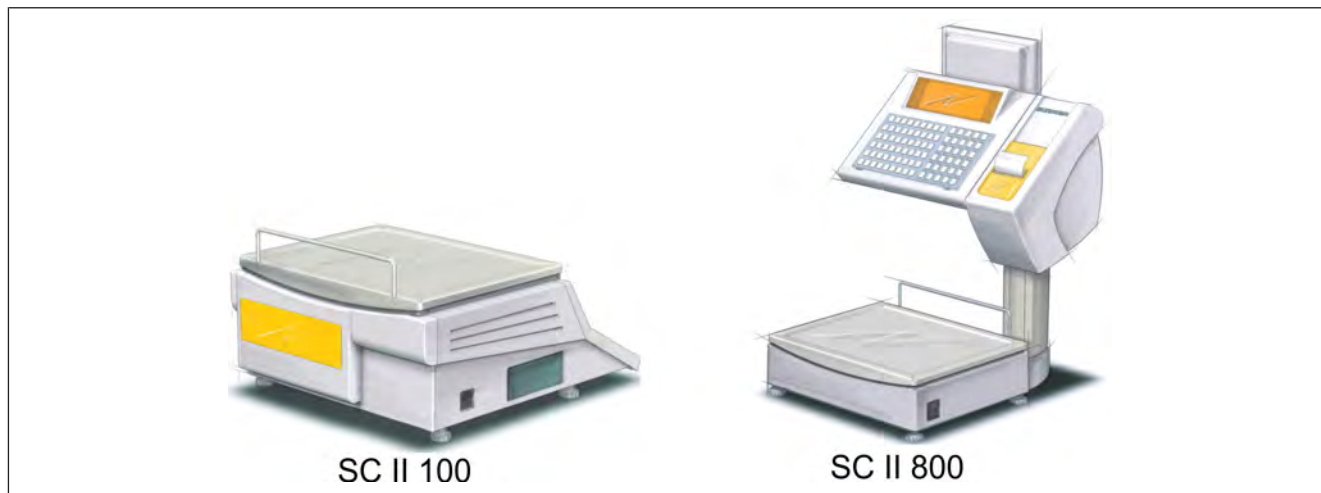

Illustration 1: SC II 100 and SC II 800

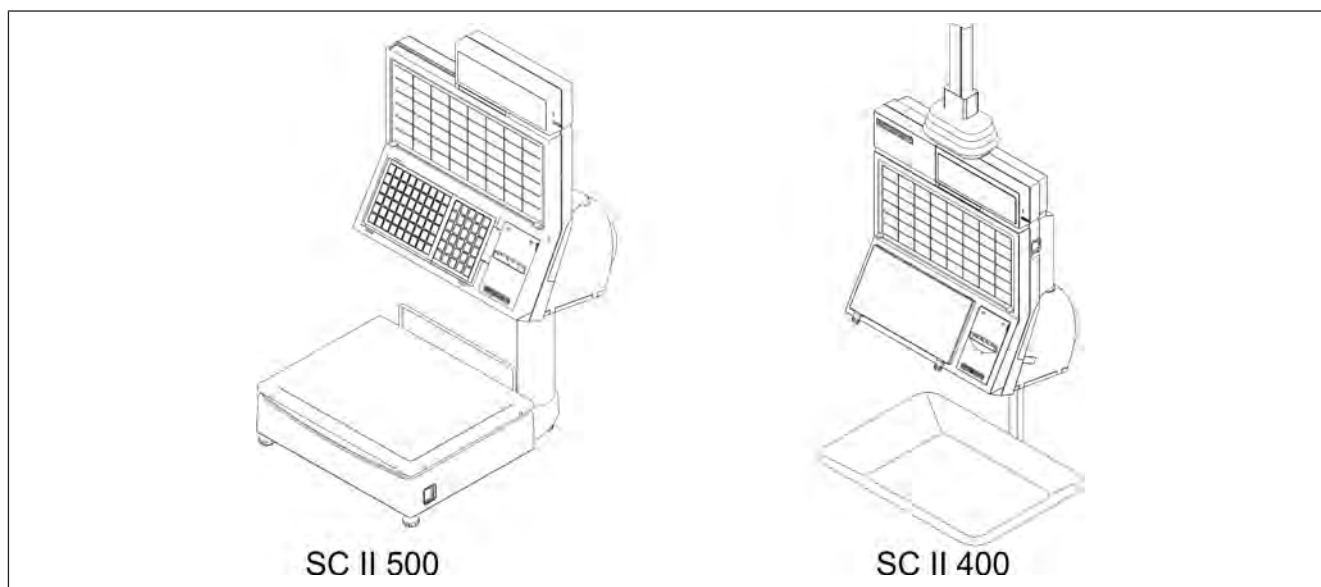

Illustration 2: SC II 500 and SC II 400

### 2.2 Accessories

Bizerba offers a wide range of accessories for this device. For further information, please contact your Bizerba specialist.

### 2.3 Intended use

System scale SC II (System Class) is a high-quality device with state-of-the-art technology designed for convenient counter sales.

Only use the device in accordance with intended use.

### 2.4 Identification plate

Example of an identification plate

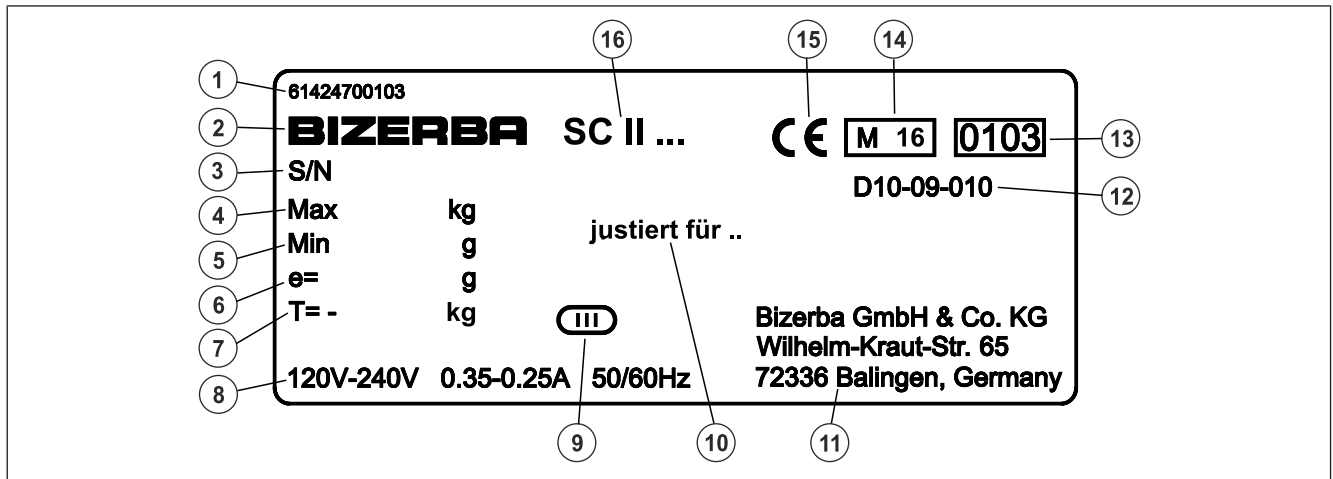

**Explanation of individual inscriptions:**

1	<b>1424700103</b>	Identification plate no.
2	<b>BIZERBA</b>	Manufacturer
3	Nr./No.	Device No.
4	Max 6 kg	Maximum load
5	Min 20 g	Minimum load
6	e = 2 g	Verification scale interval, e
7	T= - 6 kg	subtractive maximum tare load T= -
8	120-240V 0.35-0.25A 50/60Hz	Electrical data
9	III	Scale accuracy class III
10	adjusted for ...	Stating verification zone
11	Bizerba GmbH & Co. KG	Manufacturer's address
12	<b>D10-09-010</b>	No. of EC type approval
13	<b>0103</b>	Identification number of notified body "Verification body- Stuttgart"
14	<b>M 16</b>	Metrology mark Letter "M" with the last two digits of the year when the marking was attached
15	<b>CE</b>	CE marking
16	<b>SC II ...</b>	Type designation (basic type)

**2.5 Verification information**

**Note related to scales being used in Germany.**



If new or refurbished devices [...] are used, they need to be registered at the notified authority according to state law, at latest six weeks after setting into operation.

## Metrological notes for EU countries

The identification plate of the scale has a CE mark followed by the metrology mark (M + year two-digit; framed) and the number of the notified body. Until 04/19/2016 the green **M** was used as part of the metrology marking. Such a scale can be started up and operated on-site provided that it is not connected to an auxiliary device which is subject to metrological approval.

Scales which are connected on site to an auxiliary device which is subject to metrological approval must undergo a conformity assessment or metrological approval. Only then, legal for trade use is permissible.

Scales without metrology mark or control marks may not be used in legal for trade applications.

Scales calibrated for a certain gravity zone (specified on the scale) must not be used in other zones.

As per legal requirements, the scale user must ensure that the scale is used for its intended purpose. This includes the observance of legal requirements, especially in case of changes, amendments and extensions.

## Information on verification (early re-verification)

The verification of a scale is executed according to the respective statutory country regulations. The verification validity period for non-automatic scales (up to 3 tons), for example, is generally 2 years in Germany. The verification validity starts as soon as the device is put on the market.

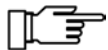

When conformity assessment is carried out by Bizerba the scale is sealed by means of control marks with marking "Gesichert BIZERBA" on the control marking locations. Verifications must be carried out by the operator of the scale according to the legal requirements.

---

## Verification information for non-EU countries

The statutory regulations of the specific countries must be observed.

## Customer ticket can be deactivated

The device offers the option of suppressing printout of the customer ticket. According to EC regulation 2009/23/EC for scales, the customer is entitled to a receipt in order to check the sales transactions in accordance with Appendix 1, No.14. Suppression of the customer ticket should therefore only be activated if you are sure that there is no customer requirement for printout of a customer ticket.

### 2.5.1 Software ID, update logbook

Software ID and update logbook are checked during a verification by the approval officer.

The software ID for the part of the software that requires verification is to be found in the current EC type approval.

## Operating procedure



Press< Mod >key



Enter password



Press < Enter >.

**Current logbook information is displayed.**

- ① Software ID
- ② Program version SC II, part is not relevant with regard to verification
- ③ Version number of legally relevant part

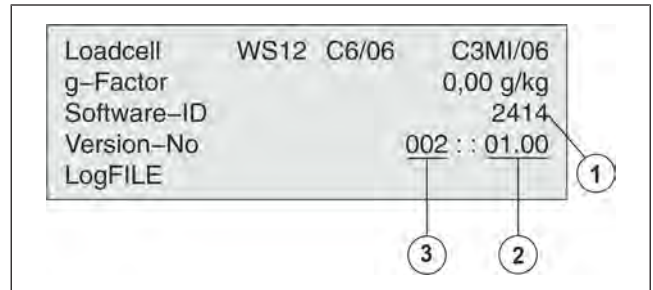



Illustration 3: Display software ID

 Press < Enter >key.

**The content of the update logbook is displayed.**

- ① Time
- ② Date
- ③ Program version SC II, part is not relevant with regard to verification
- ④ Version number of legally relevant part
- ⑤ Software ID
- ⑥ Component number
- ⑦ Department number
- ⑧ Current number of entry

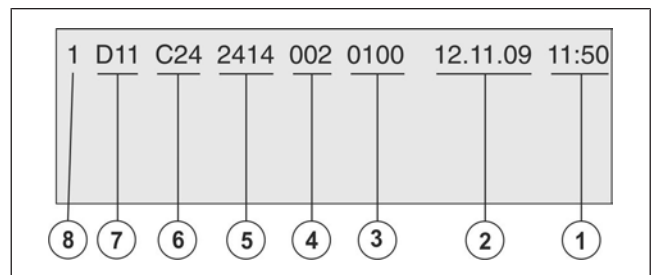



Illustration 4: Display software ID

 Scrolling through the update logbook.

 Escaping the update logbook.

**2.6 Standards and directives**

Measuring technology	
2014/31/EC	Non-Automatic Weighing Instruments Directive (NAWI)
OIML R76-Ed. 2006	Organisation internationale de métrologie légale Nonautomatic weighing instruments

Measuring technology	
DIN EN 45501	Metrological aspects of non-automatic scales
OIML R60	Metrological regulation for load cells
WELMEC 2.3	Guideline for software testing
Handbook 44	Specifications, tolerances and other technical requirements for weighing and measuring devices (USA)
Publication 14	Weighing devices, Checklist, Test procedures (USA) Weights and Measures Act (Canada)

Electromagnetic compatibility	
2014/30/EC	EMC Directive
DIN EN 61000-6-1	Immunity to interference Living area, business and industrial areas as well as small businesses
DIN EN 55022	Interference emission for information technology equipment
DIN EN 61000-3-2	Harmonic currents
DIN EN 61000-3-3	Voltage fluctuations and flickers
GB 9254-1998	Information Technology Equipment - Radio Disturbance Characteristics - Limits and Methods of Measurement

NOTICE	
	<p><b>This is a set-up for class A.</b></p> <p><b>This device can cause wireless interference in living areas.</b></p> <p>– In this case, the operator can be demanded to take suitable measures.</p>

Electrical safety	
2014/35/EC	Low voltage directive
DIN EN 60950-1	Information Technology Equipment - Safety

## 2.7 Operating conditions

- ⇒ Please note the operating conditions prior to start-up and during operation.
- ⇒ If you are in doubt concerning the practical application of these conditions, please contact Bizerba or the responsible customer service.

For other manufacturers' equipment included in our scope of supply, the respective manufacturer's regulations take preference if they deviate from our conditions.

– **Temperature and air humidity**

The permitted values and protection type can be found on the identification plate on the device and in the chapter Technical data.

– **Installation surface**

Make sure to install the device on a level surface in a dry place free of vibration and oscillation and protected from drafts.

Vibrations can affect measurements made by the scale.

– **Aligning horizontally**

To ensure the precision of the sale, it is of absolute necessity that the device is aligned horizontally.

– **Draft**

Air drafts can affect the measurements made by the scale.

– **Air convection**

In order to prevent unacceptable heating, there must be free air convection around the device.

– **supply voltage**

The permitted values can be found on the designation plate on the device and in the chapter on technical data.

– **Trained personnel**

Only trained personnel can maximize the performance of the device and avoid risks.

– **Written consent for modifications**

Changes to the devices require prior written consent of Bizerba. External data dialog between Bizerba equipment and third-party equipment, required hardware and software as well as test and modification work must be clarified with Bizerba in writing.

### 2.7.1 Power supply

The installation of the power supply for connecting to Bizerba devices must be carried out in accordance with the international specifications and the regulations derived from them.

These essentially include the recommendations of at least one of the following commissions:

- NEC (UL)
- International Electro-technical Commission (IEC)
- European Committee for Electro-technical Standardization (CENELEC)
- German Association for Electrical, Electronic and Information Technologies (VDE)

Bizerba devices must be connected to a protective conductor.

#### Interference suppression

If the mains power supply is subject to electric interference, interference suppression measures must be taken on site, e.g.:

- provision of separate mains line to our devices.
- In case of problems, insertion of capacitively decoupled isolating transformers or other suppressors into the mains supply lines to Bizerba device.

## 2.7.2 Wireless LAN device network

Wireless LAN is a wireless network solution, that enables electronic devices to be networked together without wiring.

The rules on the respective general allocation of frequencies must be observed.

---

### The following instructions must be absolutely observed!



- When wireless networks are deployed, (including those supplied by Bizerba and those not supplied by Bizerba), the required transmission power set and frequency channels at Federal state level must be strictly observed.
- Only wireless hardware is permitted in wireless networks that has been released for use by the manufacturer in the country in which it is to be deployed.
- If third parties access the network or wireless network, or if the network is combined with foreign hardware, Bizerba is not liable for any damages that result.

---

## 2.8 Warranty

Installation, start-up and initial training are carried out by trained staff of the Bizerba sales offices, customer service locations or by companies commissioned by Bizerba.

### **Bizerba is not responsible for damages caused by:**

- non-observance of operating conditions and operating instructions.
- defective electrical installation by the customer.
- structural changes to the devices.
- removal of verification seals and safety stamp marks.
- incorrect programming and operation.
- natural wear and tear.

### **The warranty will lapse, if:**

- defects/damages occur as a result of interventions by persons not authorized by Bizerba.
- any spare parts or operating material other than original Bizerba ones are used.
- any thermal ticket rolls and labels other than original Bizerba ones are used.
- Labels and thermal ticket rolls are used, which have not been manufactured to Bizerba specification or approved by Bizerba.

If you reset or program devices, check the new setting with a test run and test printout. This helps to avoid incorrect results.

Only trained staff may operate the devices.

Check that Bizerba products are handled correctly and repeat training if necessary.

Bizerba products undergo continuous further development and are subject to different country-specific regulations. Examples of pictures and graphics contained in these operating instructions may vary from the version which you received.



## 2.9 Demo license

The device is equipped with basic software. The device is also equipped with the purchased software modules.

In addition, the device is enabled with all software modules included in the program version for a specific period of time, so that the customer can use all software modules without restriction for a specific time. This gives the customer the opportunity to test software modules that he has not purchased. The customer can purchase these additional software modules at any time.

Software modules that are purchased subsequently require special activation.

If the additional software modules are not released, you can no longer use them once a specific time period has expired.

The additional software modules are provided exclusively for demonstration purposes. There is no entitlement to free provision after expiry of the set time period.

Please contact your technical consultant or Bizerba at any time for further information.

## 2.10 Software by third party

A JPEG library is used in the software. It does not require a license. This software is based in part on the work of the Independent JPEG Group.

## 2.11 Disposal of devices/environmental protection



**Only valid for Germany!**

**The application of the disposal regulations is based on legal regulations of the respective country.**

This device contains batteries which fall under the Batteries Act for the return and disposal of used batteries and accumulators.

This ordinance requires you, as the end user, to return the device to the manufacturer or dealer, at the end of its proper use, for the purposes of recycling and correct disposal.

Bizerba and its dealers are naturally willing to take back these defunct old devices.

Please contact your specialist in these cases.

If your device contains a rechargeable battery, you are required by the Battery Ordinance to return the used battery to the dealer or the public return points provided for this purpose.

Naturally, Bizerba and its dealers will also take back the used batteries.



### **⚠ CAUTION**

**Risk of explosion if batteries are not replaced properly.  
Please follow the manufacturer's instructions when disposing of used batteries.**

### 3 Safety instructions

The safety instructions must be observed throughout the installation, operation, cleaning and maintenance procedures.

#### 3.1 System-related sources of hazards

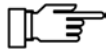

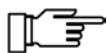

For safety reasons, the machine should be turned off immediately if it displays faults repeatedly, or damage is incurred of any type or if there is suspicion of a risk of injury.

Always inform the nearest customer service point.



– **Check before mains connection**

- Before connecting the device, check
- mains data on identification plate
- mains data of the mains supply.

	<p><b>⚠ WARNING</b></p> <ul style="list-style-type: none"> <li>– <b>Wrong supply voltage!</b></li> <li>– Do <b>not</b> connect device to the main supply if the mains data does not correspond to the application specifications of the scale. <b>Mains data must be identical.</b></li> <li>– Please contact the Bizerba customer service.</li> </ul>
	<p><b>⚠ CAUTION</b></p> <p><b>Switched-off scale is still energized</b></p> <ul style="list-style-type: none"> <li>– Even when the scale is switched off, the scale electronics is energized.</li> <li>– Pull out the power plug to de-energize the device.</li> <li>– In case of the SC II 400, use the customer-provided mains switch, e.g. emergency-stop switch.</li> </ul>
	<p><b>⚠ WARNING</b></p> <p><b>Opening the device!</b> <b>Electric shock</b></p> <ul style="list-style-type: none"> <li>– Opening the device must be carried out by trained and qualified Bizerba personnel only.</li> </ul>

### **3.2 Requirements for operating personnel**

The device must only be operated by personnel trained in the operation of this equipment. The operating personnel must read and understand the safety instructions in these operating instructions.

Please pay special attention to and memorize all safety and hazard information! Carry out regular training!

Operators (purchasers) as well as supervisory and operating staff must carry out programming and data protection on Bizerba systems and devices exclusively in accordance with the Bizerba operating and programming instructions.

Only use equipment for its intended purpose.

## 4 Installation

### 4.1 Transport and storage

Always transport and store the device in its original packaging.

### 4.2 Start-up

Putting into operation, as well as instruction on the operation, cleaning, maintenance and servicing is carried out by the relevant Bizerba customer services office or the Bizerba trade consultant.

#### 4.2.1 Switching device on

Switch device on and off [▶ 40].

Requirement for this is:

- The device has been installed properly and connected to the mains power supply.
- The scale should not be loaded.

### 4.3 Decommissioning

If you wish to place the scale out of operation for a long period of time,

- switch off the scale.
- Unplug the mains cable and all cable connections.
- Clean the scale following the cleaning instructions.

### 4.4 Setting the display

The display is set to preferred values in the works.

Depending on the lighting conditions at the place of installation, these preferred values can be changed.



Switch on display controls.



Close display controls.

#### Menu:

database config. [ ]

Brightness of operator display [7]

Contrast of operator display [40]

Contrast of customer display [40]

#### database config.

When the function is on, brightness and contrast are set in the menus to the standard values, 7 and 40.

#### Brightness of operator display

The preferred value for brightness is set automatically and should be changed in relation to the lighting conditions.

### Contrast of operator display/customer display

The preferred value for contrast is set automatically and should be changed in relation to the lighting conditions.

## 4.5 Installation and assembly

Installation, first commissioning, adjustment, initial instruction, maintenance and repair work may only be performed by our customer service and/or by companies or persons authorized by us.

### 4.5.1 Assembling the device

Open packaging, remove accessories and lift the device carefully out of the packaging.

### 4.5.2 Leveling

To compensate for any small irregularities in the floor space, the scale can be leveled at the foot screws using a spirit level.



After each change of location, the scale must be re-leveled.

- ① Position of spirit level
- ② Foot screws

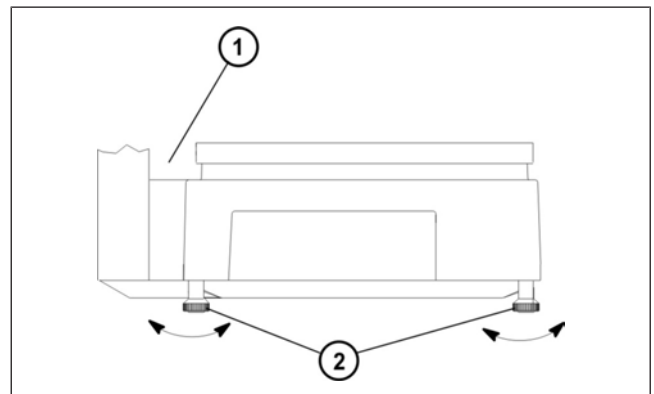

Illustration 5: Foot screws

- ⇒ Turn the foot screws ② until the air bubble ③ is located in the center of the spirit level ①.

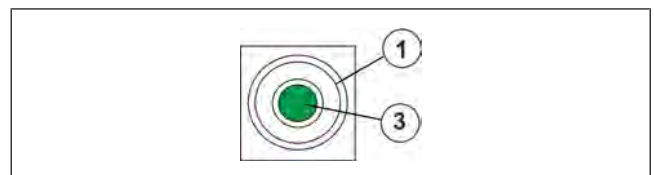

Illustration 6: Device is leveled correctly

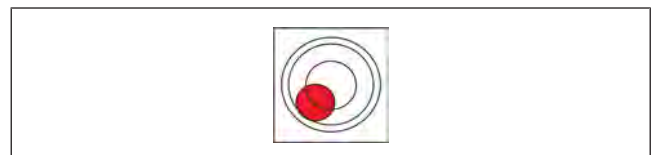

Illustration 7: Device is not leveled correctly.

### 4.5.3 Check the electric connection

Power supply

### Installation of power supply provided by customer

The installation of the power supply for connecting to our equipment must be carried out in accordance with the international specifications and the regulations derived from them. These essentially include the recommendations of at least one of the following commissions:

- International Electro-technical Commission (IEC)
- European Committee for Electro-technical Standardization (CENELEC)
- German Association for Electrical, Electronic and Information Technologies (VDE)

#### Check before connecting to mains!



- Before connecting the device, check
- mains data on identification plate.
- mains data of the mains supply.

	<p><b>⚠ WARNING</b></p>
	<ul style="list-style-type: none"> <li>– <b>Incorrect supply voltage!</b></li> <li>– Do <b>not</b> connect device to mains supply if mains data does <b>not</b> match the connection values of the scale. <b>Mains data must be identical.</b></li> <li>– Inform Bizerba Customer Service.</li> </ul>

### 4.5.4 Cable connections

	<p><b>CAUTION</b></p>
	<p><b>Do not insert or remove connecting cable while device is switched on!</b></p> <p><b>Interfaces are either defect or malfunctioning.</b></p> <ul style="list-style-type: none"> <li>– Always switch device off before inserting or removing the connecting cable.</li> </ul>



Secure power cable from falling out by means of strain relief.

- ① Mains cable
- ② Clip (strain relief)
- ③ Cash desk connection
- ④ Plate (strain relief)
- ⑤ COM 2
- ⑥ ETHERNET
- ⑦ Com 1(scanner; E-Cash; coin dispenser)
- ⑧ USB (only with SC II 7")

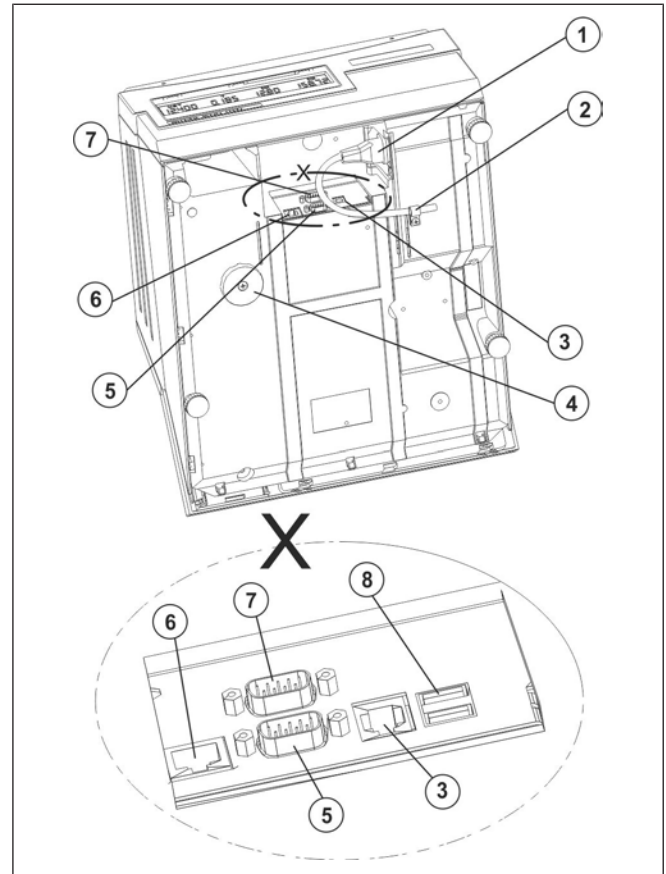

Illustration 8: Cable connection SCII 100

- ① Clip (strain relief)
- ② Mains cable
- ③ Plate (strain relief)
- ④ Cash desk connection
- ⑤ ETHERNET
- ⑥ COM 2
- ⑦ Com 1(scanner; E-Cash; coin dispenser)
- ⑧ USB (only with SC II 7")

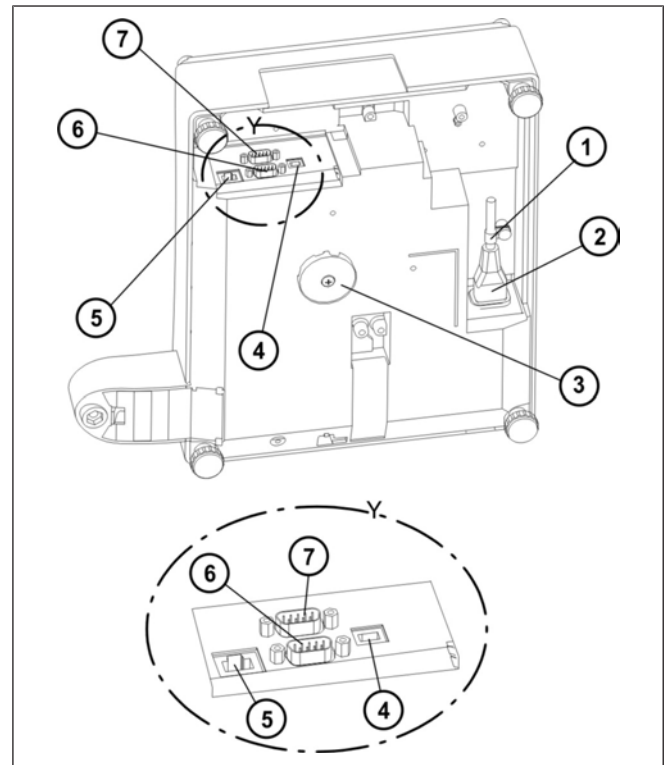

Illustration 9: Cable connection SCII 800

### 4.5.5 Rechargeable battery

The devices are available with and without batteries.

The installation or removal of the battery may only be carried out by our customer services and/or a company or person assigned by us.

The device can be operated without a mains power supply if a battery is installed.

Operating time: SC II 10 hours, SC II 7" 4 hours. The rechargeable battery time is dependent on the ambient temperature and on the brightness setting.

During battery operation, the brightness of the customer display is reduced. This preserves the battery resulting in longer battery life.

With battery operation, printing speed is 66mm/sec.

Rechargeable batteries will run down even during prolonged idle periods if the scale is not connected to the mains. For this reason, connect the scales to the mains power supply every 3 months at the latest.

If the scale is connected to the mains, the batteries are recharged while the scale is being **switched** on (conservation charging). Charging time approx. 3.5 hours.

Overloading the batteries is prevented automatically by an integrated charging circuit. This charging circuit also prevents any damaging total discharge. The battery lifetime reduces if it is permanently operated at an almost discharged state.



## 5 Device and operating controls

### 5.1 Main switch

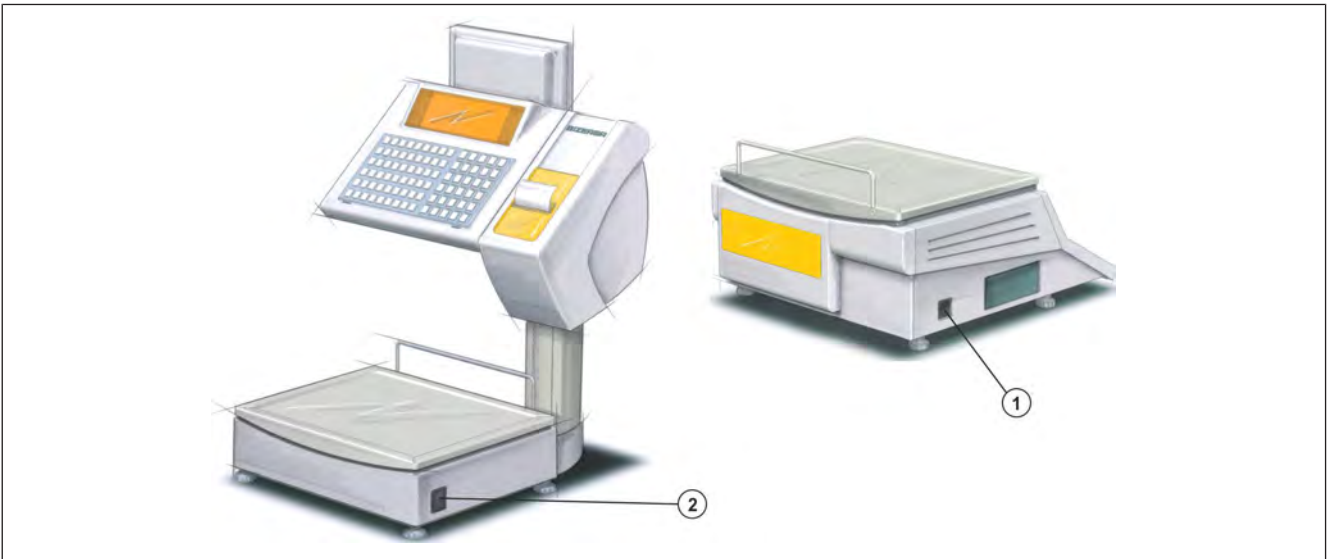

Illustration 10: Power switch

- ① Power switch for SCII 100
- ② Power switch for SCII 800

### 5.2 Display

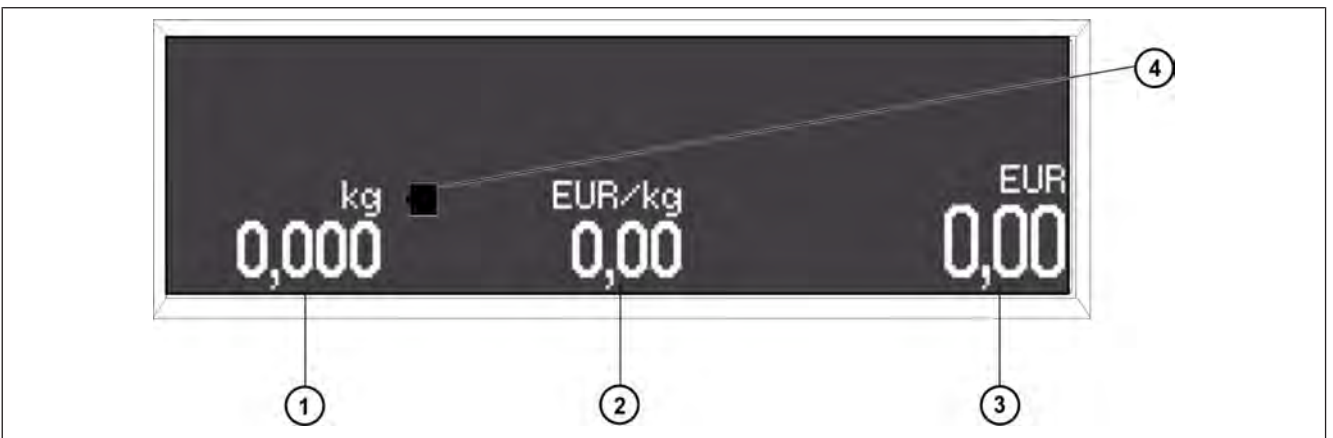











Illustration 11: Example of display

- ① Weight value
- ② Unit price
- ③ Selling price
- ④ Display icon (e.g. battery operation)

#### 5.2.1 Display icons

Symbol	Operating mode	Status
No symbol	Mains operation	Fully charged battery

Symbol	Operating mode	Status
	Mains operation	Battery is being charged Charging time approx. 3.5 hours
	Mains operation (flashing)	Battery temperature < 0°C. No statement can be made about the charge status of the battery. Battery is not being charged.
	Battery operation	Battery full (100%) Operating time SCII approx. 8-10 hours Operating time SCII 7" approx. 4 hours
	Battery operation	Battery 3/4 full (75%)
	Battery operation	Battery 1/2 full (50%)
	Battery operation	Battery 1/4 full (25%)
	Battery operation	Battery will be drained soon but no alarm yet
	Battery operation (flashing)	Reserve! Battery drained soon (warning threshold can be set). Scale can still run for another approx. 15 min.
	Battery operation (flashing and sound)	Battery is flat. A beeping tone sounds for approx. 10 seconds. The scale shuts automatically down.

### 5.3 Keyboard



Keyboard designs are country-dependent.

### 5.3.1 Membrane keyboard

There are two transparent modules on the membrane keyboard into which insert-foils can be inserted if required.

- ① Insert foil 30 keys DEU (country ID, e.g. DEU, defines keyboard labeling)
- ② Insertion foil 54 keys DEU
- ③ Foil keyboard 54 keys
- ④ Foil keyboard 30 keys

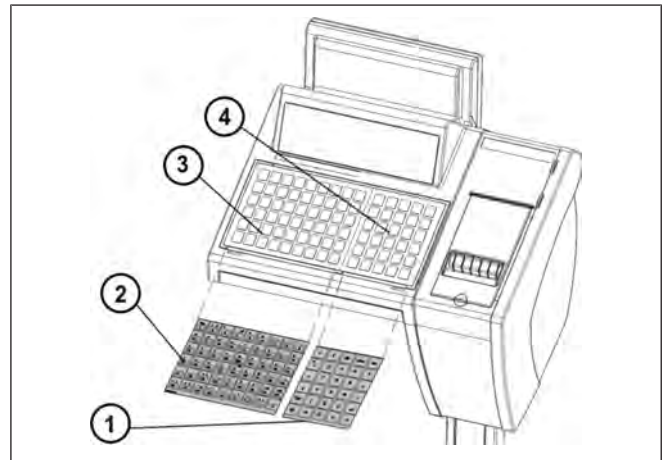

Illustration 12: Example of insert-foils



Illustration 13: Insert foil 54 keys



Illustration 14: Insert foil 30 keys

### 5.3.2 Tactile keyboard

① Tactile keyboard 84 keys

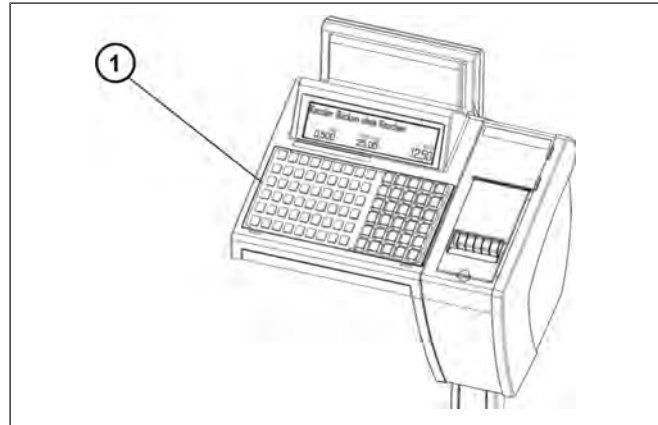

Illustration 15: Tactile keyboard

### 5.3.3 Key functions



The basic and extended keyboards for the scales can be freely configured with the exception of only a few keys.

To do this, select "Assign keys" in the configuration **5312**.

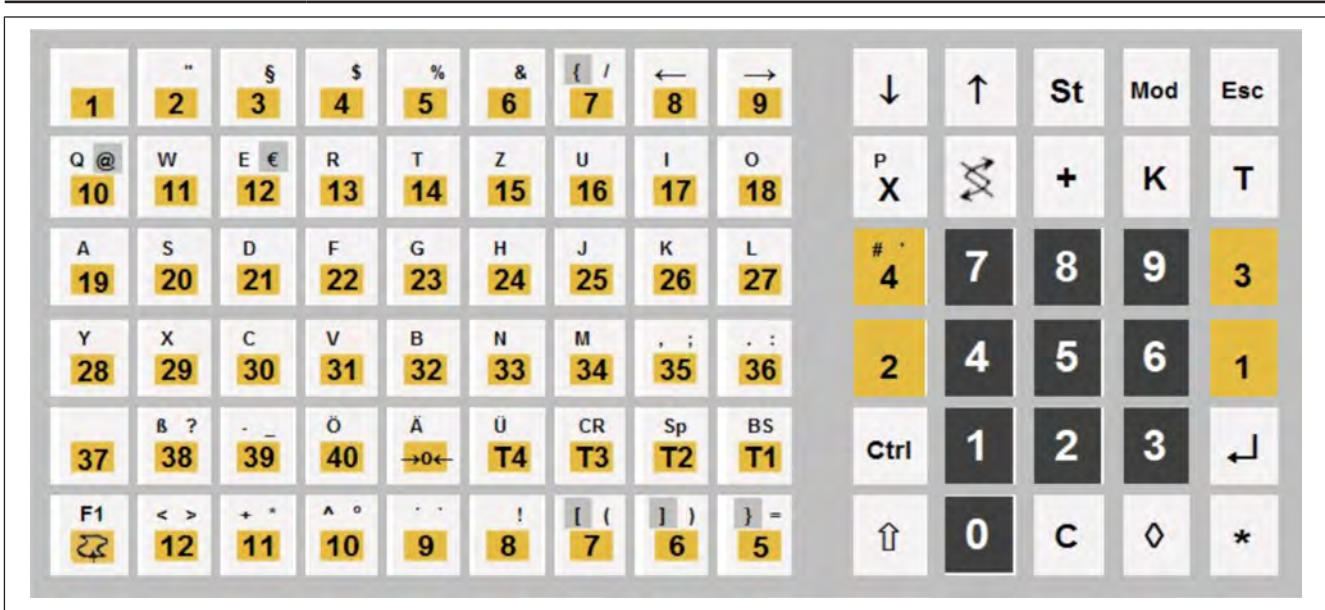

Illustration 16: Example of keyboard

#### Key



#### Standard function

<PLU 1> to <PLU 50>



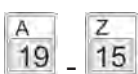











PLU = Price Look Up (product plus price, text, etc. is displayed)



Non-numeric and special characters <A> to <Z>, (function only in menu)



Operator 1 <OP1> to Operator 4 <OP4>

	<Paper feed>
	<Minus input>
	<Zero setting>
	<Scroll>
	<Cancellation>
	<Paper feed>
	<Mod>
	<Escape>
	<Multiplication>
	<Switch over><Overwrite>
	<Manual input>
	<Constant>
	<Tare>
	<Control>
	<Enter>
	<Shift>
	<Clear> (delete)
	<Subtotal>
	<Total>

## Two keyboard levels

### Menu settings

- In the configuration place key<Switching PLU level> to the basic keyboard. Select: **5 3 1 2**.
- In the PLU maintenance create the direct PLU keys for level 2. Select: **1 6 1**.

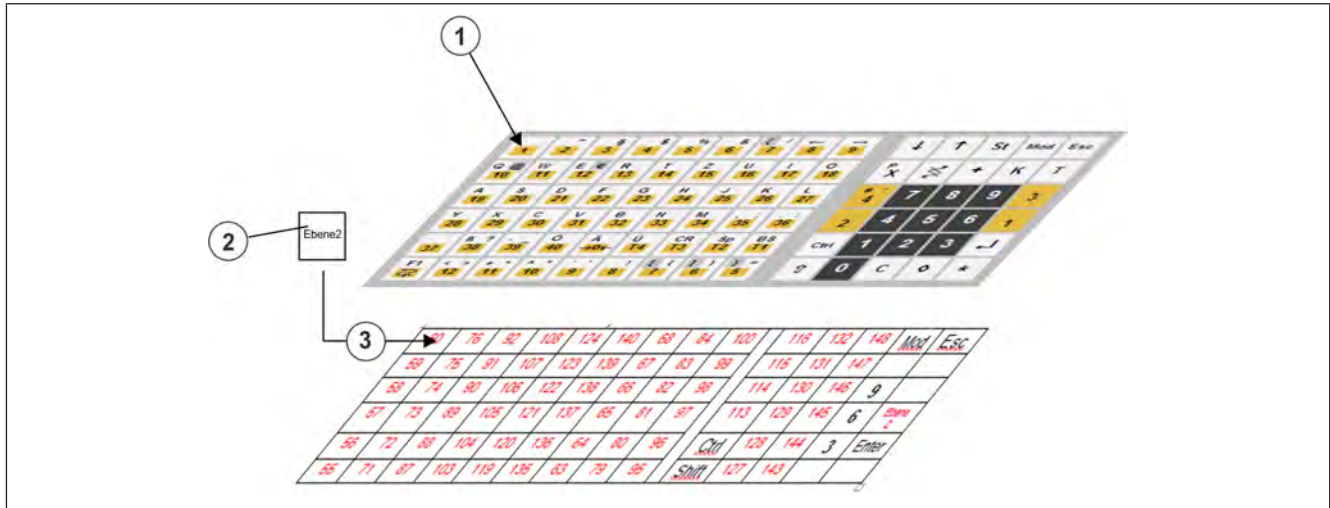

- ① Keyboard level 1
- ② Switch key "PLU level"  
Level 2 is activated.
- ③ Keyboard level 2

## 5.4 Printer

The models are fitted with linerless or label printers. The printers operate according to the thermal printing principle. The paper can only be printed on the thermal side.

### 5.4.1 Printer lid and side cover for SC II 100/200

#### Printer lid SC II 100/200

##### Opening

The printer cover ② has a handle on top ③.

- ⇒ Take hold of the printer lid at the recessed handle ③.
- ⇒ Open the printer lid by pulling it downwards.

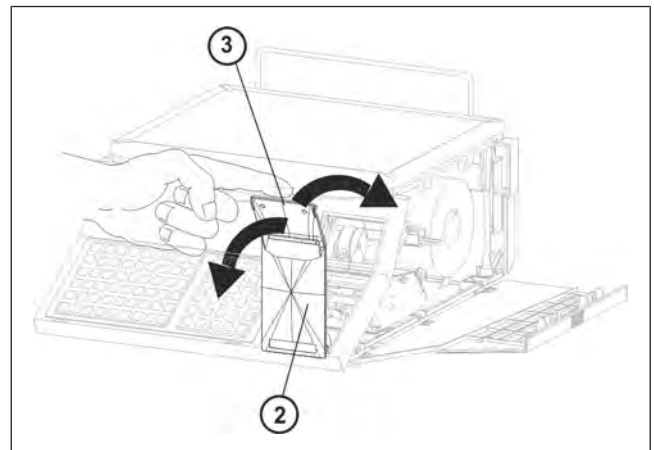

Illustration 17: Printer lid SC II 100/200

### Closing

- ⇒ Fold the printer lid upwards.

### Side cover SC II 100/ 200

#### Opening

- ⇒ Hold the side cover ① at the fluted grip.
- ⇒ Open the side cover pulling it downwards.

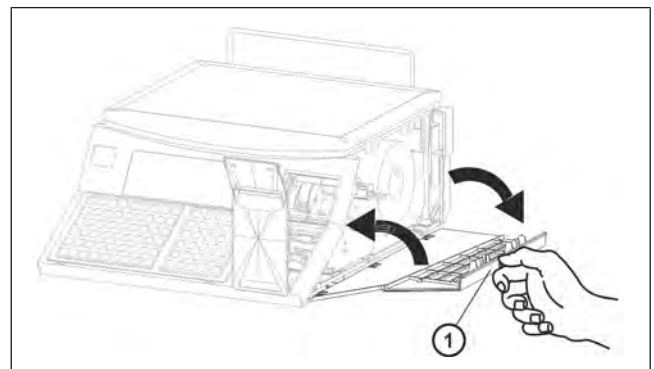

Illustration 18: Side cover SC II 100/ 200

### Closing

- ⇒ Close the side cover by pulling it upwards.

## Printer lid and side cover for SC II 800

### Side cover SC II 800

#### Opening

- ⇒ Hold the side cover ① at the recessed handle.
- ⇒ Open the side cover pulling it downwards.

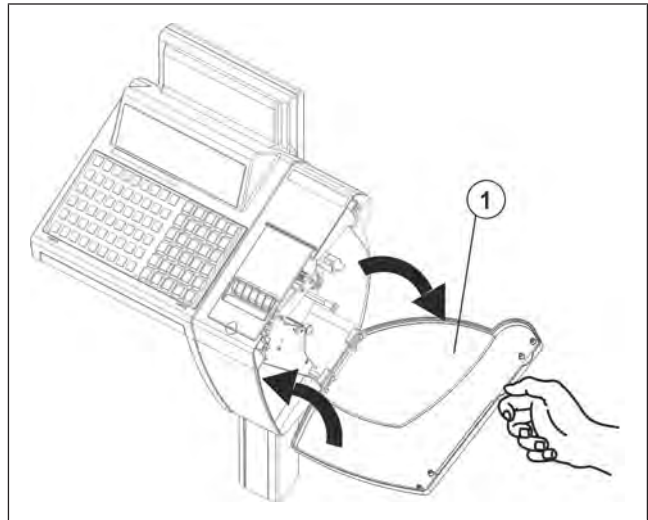

Illustration 19: Side cover SC II 800

#### Closing

- ⇒ Close the side cover by pulling it upwards.

### Printer cover

#### Opening

- ⇒ Take hold of the printer lid at recessed handles ②.
- ⇒ Open the printer lid by pulling it upwards.

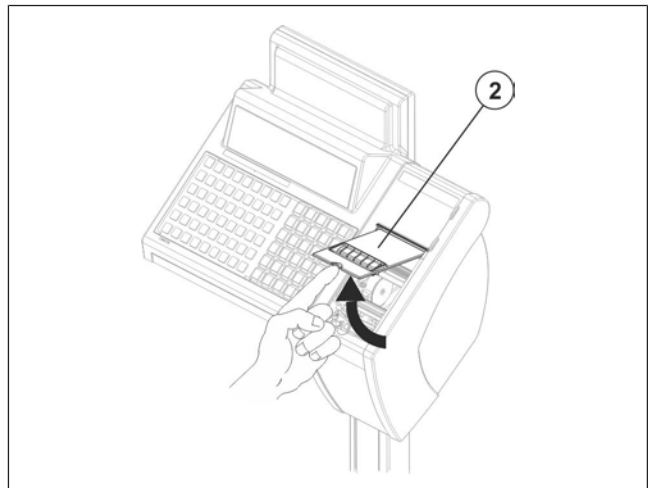

Illustration 20: Open SC II 800 printer lid



## Closing

⇒ Fold the printer lid ② down.

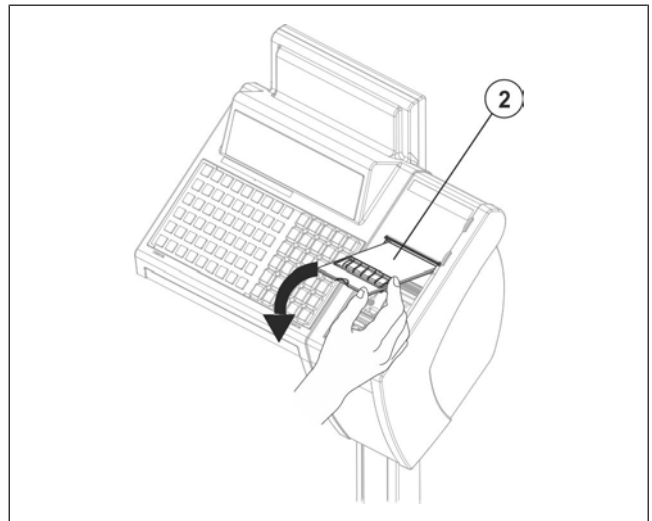

Illustration 21: Close SC II 800 printer lid

### 5.4.2 Opening and closing the thermal print head

#### NOTICE

- The thermal strip is coated with a glass passivation layer and must not be touched or cleaned with hard objects.

#### Label printer in SC II 100/200

##### Open

- ⇒ Place one finger underneath the red grip element ①.
- ⇒ Pull the grip element towards you until the ① thermal print head ② disengages and moves downwards.

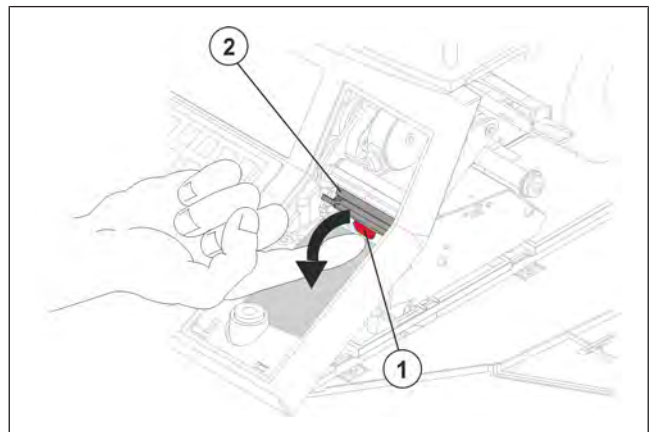

Illustration 22: Label printer in SC II 100

##### Close

- ⇒ Place your finger on the red grip element ①.
- ⇒ Press the thermal print head ② upwards against the printer roller and then backwards until the thermal print head engages.

## Label printer in SC II 800

### Open

- ⇒ Place your index finger underneath the red grip element. ①.
- ⇒ Push the grip element ① upwards until the thermal print head disengages.
- ⇒ Move the thermal print head ② forwards.

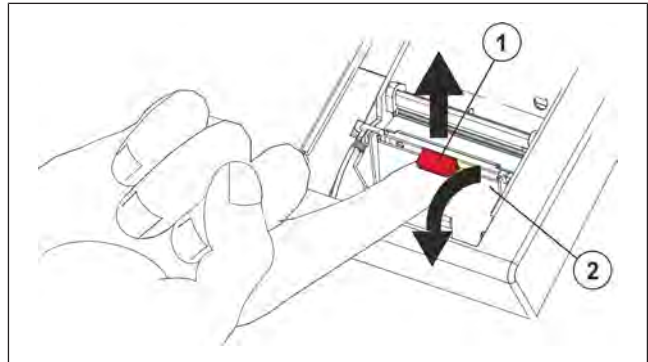

Illustration 23: Opening the thermal print head

### Close

- ⇒ Place your thumb on the red grip element.
- ⇒ Push the thermal print head backwards against the printer roller and then downwards until the thermal print head engages.

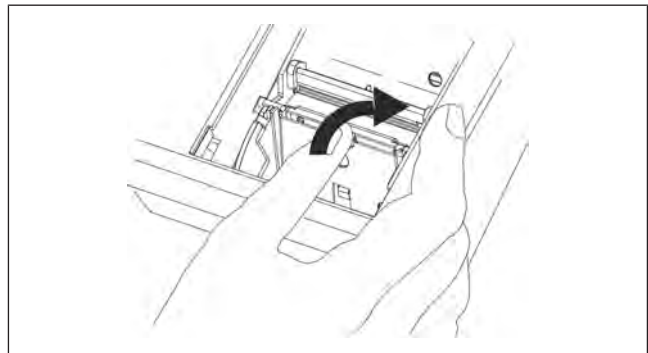

Illustration 24: Closing the thermal print head

## 5.4.3 Label printer

After printing the last label, insert a new label roll.

## Insert label roll

- ➔ Open the side cover and printer cover [▶ 30].
- ➔ Open the thermal print head [▶ 33].
- ➔ Remove the label roll from the take-up pin ③.
- ➔ Pull the red peel-off unit ⑥ outwards.
- ➔ Pull the backing paper off the unwinding shaft ①.
- ➔ Pull 5 labels off the backing paper of the new label roll.
- ➔ Place the new label roll ④ on the take-up pin ③.
- ➔ Insert the backing paper in accordance with paper feed and attach it to the take-up pin ①. The backing paper must be aligned to the flange ②.
- ➔ Press the red peel-off unit ⑥ inwards.
- ➔ Turn the take-up pin ① manually until the first label is peeled off.
- ➔ Close the thermal print head [▶ 33].
- ➔ Close the side cover and printer cover [▶ 30].

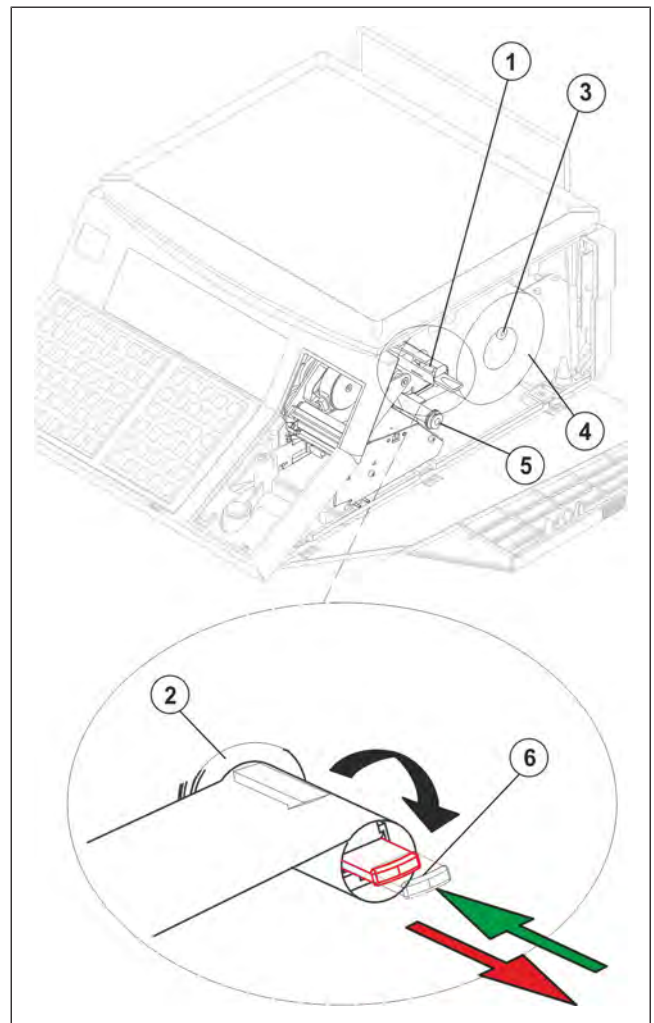

Illustration 25: SC II 100 Label printer

### 5.4.4 Ticket roll

#### Run out of ticket paper

If the ticket roll is empty, the following status message appears: "Printer 1: end of paper"  
The remaining paper is automatically rejected.

#### Menu setting

- Automatic paper infeed only with printer operating mode "Ticket" or "Label printout on ticket". Select **5 3 2 2 4**

## Insert new ticket roll

- ⇒ Open side cover and printer cover [▶ 30].  
The thermal bar ④ must **not** be opened.
- ⇒ Remove the empty core of the ticket roll.
- ⇒ Insert a new ticket roll ②.
- ⇒ Lead the ticket paper to the printer roller ⑤ according to paper feed.  
After a short time an automatic paper in-feed is activated.

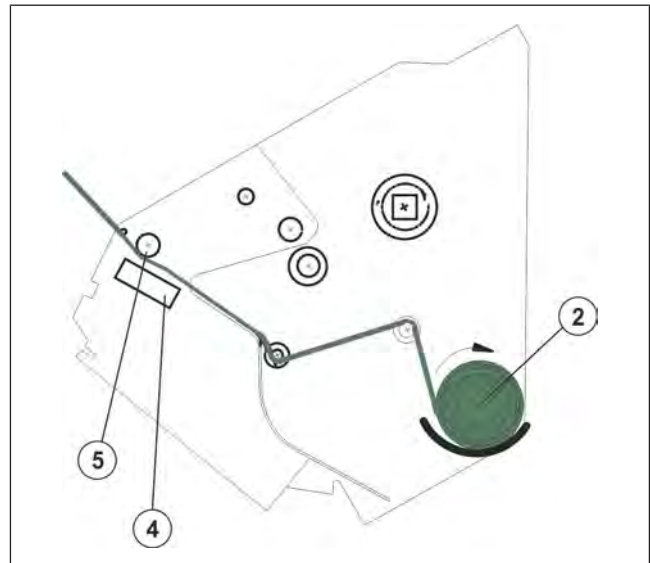

Illustration 26: Paper track for ticket paper / SC II 800

- ⇒ Move paper forward using the <Paper infeed> key.
- ⇒ Confirm status message "Ticket printout or" by pressing <Enter>.
- ⇒ Close side and printer cover [▶ 30].

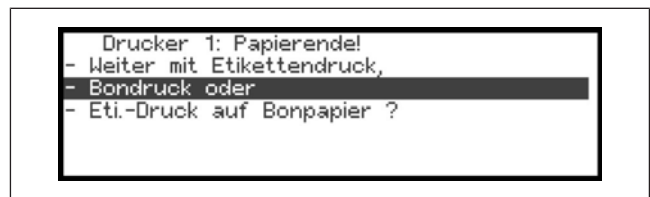

Illustration 27: Status message

### 5.4.5 Paper feed

#### Paper feed SC II 800

##### Paper feed label printer with label paper

- ① Take-up arbor for backing paper
- ② Collar
- ③ Takeup shaft
- ④ Label roll
- ⑤ Deflection pin with red adjustable ring
- ⑥ Print head
- ⑦ Print roller
- ⑧ Label detachment shaft
- ⑨ Deflection pin
- ⑩ Transport roller
- ⑪ Deflection roller with adjustable ring

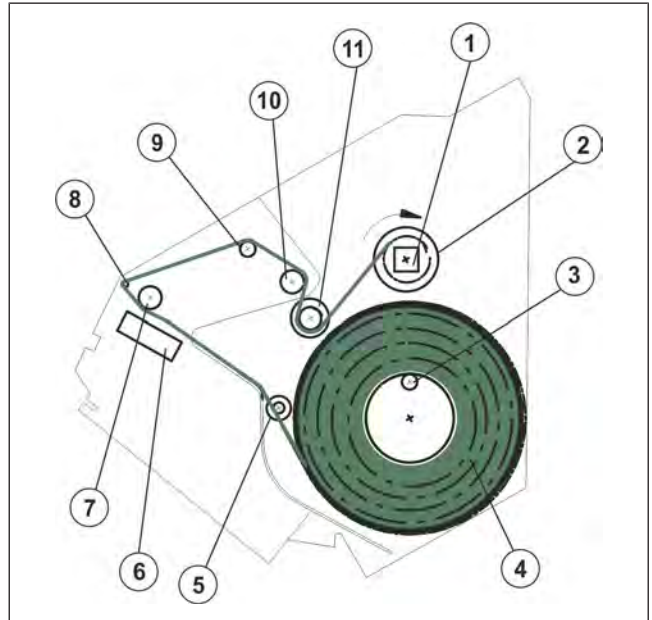

Illustration 28: Paper feed for label paper / SC II 800

##### Paper feed label printer with ticket paper

- ① Takeup shaft
- ② Ticket roll
- ③ Deflection roller with red adjustable ring
- ④ Print head
- ⑤ Print roller

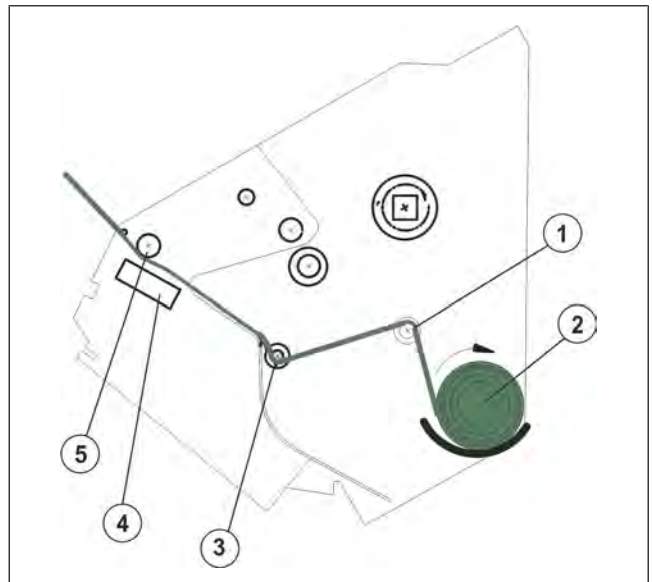

Illustration 29: Paper track for ticket paper / SC II 800

## Paper feed SC II 100/200

### Paper feed label printer with label paper

- ① Take-up arbor for backing paper
- ② Collar
- ③ Takeup shaft
- ④ Label roll
- ⑤ Deflection pin with red adjustable ring
- ⑥ Print head
- ⑦ Print roller
- ⑧ Label detachment shaft
- ⑨ Deflection pin
- ⑩ Transport roller

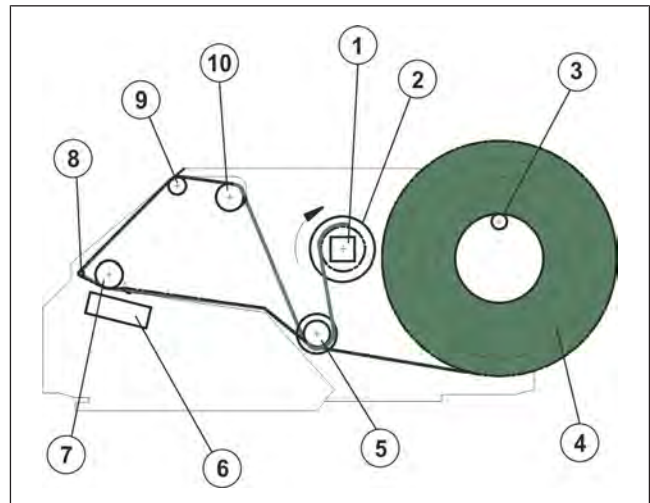

Illustration 30: Paper feed for label paper/SC II 100/200

### Paper feed label printer with ticket paper

- ① Ticket roll
- ② Deflection roller with red adjustable ring
- ③ Print head
- ④ Print roller

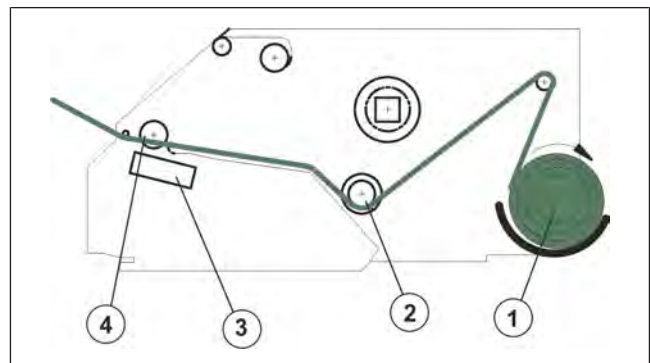

Illustration 31: Paper feed for ticket paper/SC II 100/200

## Set paper width

- ➔ Move the red adjustable ring (5) on the deflection roller to adjust it to the label width. This adjustment is necessary each time the paper or the paper width change.

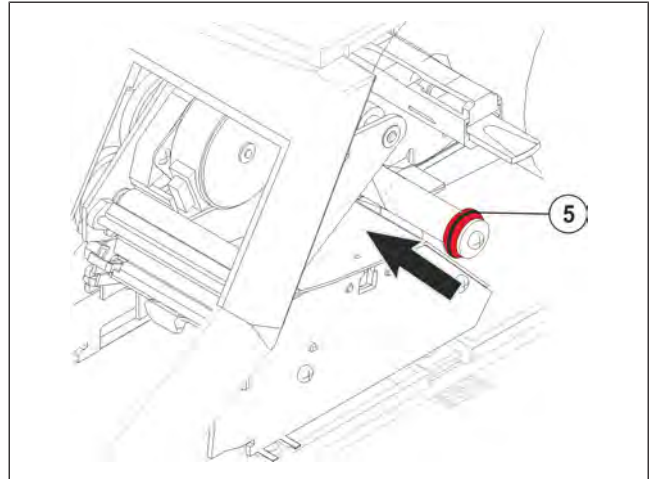



Illustration 32: Adjustable ring

## 6 Operation

### 6.1 Switching device on

The mains switch <On-Off>  is located:

- on the left side of SC II 100 scales
- on the right side of SC II 800 scales.

The scale should not be loaded.



Press <On-Off> power key.

After switch-on, the device runs through a start procedure.

The device is ready for operation when the initial display appears.

After that the weight display ranges automatically at zero "0.000" kg provided that the scale is unloaded.

#### ① Initial scale display



Illustration 33: Initial display

### Keyboard check

When switching on the device, a keyboard check is automatically carried out. If an error is detected, the following message appears.

- ⇒ The mechanical coordinate of the defective key is displayed.  
X axis = 3 ① and Y axis = 1 ②.
- ⇒ Localizing of key by means of the coordinates ③.
- ⇒ Contact service department.

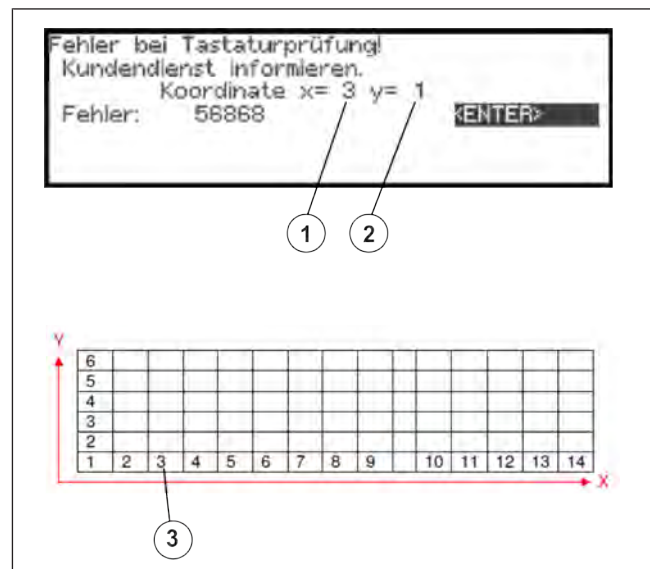

Illustration 34: Keyboard error



## 6.2 Switch off device



Press <On-Off> power key.

The device runs through a switch-off procedure.

The display goes dark after a short time.

## 6.3 Resetting the device

After switching on the scale the weight display ranges automatically at zero "0.000" kg provided that the scale is unloaded.

The scale has an automatic reset device, so that minor zero point changes are compensated automatically.

### Manual zerosetting

#### Menu setting

- Create key <Scale zerosetting>in configuration. Select **5 3 1 2**.

The weight value display can (if the display is not set to zero) be reset again with the scale unloaded.



Press key <Scale zero setting>.

The weight value display indicates "0.000" kg.

## 6.4 Correction options

### 6.4.1 Canceling function

A function called by mistake can be canceled. The device returns to the initial display.



Call up function "Unit price input".



Cancel function "Unit price input".

### 6.4.2 Deleting characters

Individual characters can be erased while values are being entered. This applies to the following values: PLU no., price, tare, number of pieces, quantity.



Entering a PLU no.



Delete character entered last.

## 6.5 SC II 100 K/B

With the SCII 100 K/B (K =POS terminal, B= Bakery), weight determination and linked functions (taring, pricing with determined weight etc.) are not possible. The device runs automatically on POS license. The operating processes and functional settings are mainly identical with a scale. There are only differences in operating processes where weight value is used, e.g. PLU with PLU type "Weighed".

### 6.5.1 Switching device on

The output display of the Bakery device differs from the scale display.

- ① Initial display SCII 100 K/B

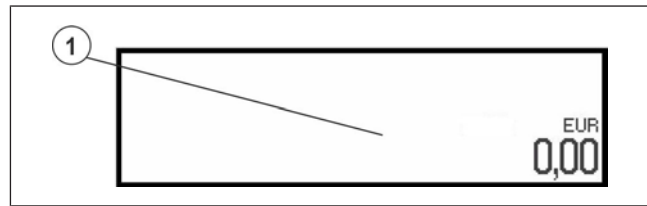

Illustration 35: Initial display

### 6.5.2 SC II 100 K/B operation with weight value

#### Menu setting

- In configuration <Basic sales setting> Select 5363 / PLU No. basic setting
- Select "Unit price input" in the standard menu.

#### PLU with PLU type "weighed"

⇒ Call-up PLU with type "Weighed".



Illustration 36: Example: Operating display



Press <Multiplication> key and enter known weight.

Display switches to manual weight value.



Illustration 37: Manual weight input



Register using operator key, e.g. <OP1>.

The operator and the registered items are displayed.

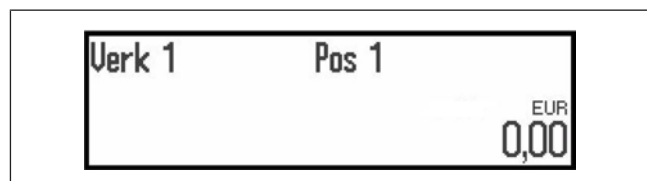

Illustration 38: Operator display operator



Press the <Total> key.

Request "Enter operator" is displayed.

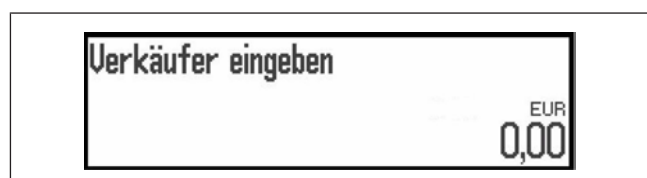

Illustration 39: Enter the operator



Press operator key, e.g. <OP1>.

Total is displayed and ticket printed.

If "Pay-in/pay-out" is set, the pay-in/pay-out mode is started before total printout [▶ 61].

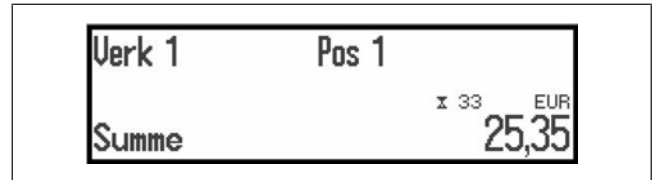

Illustration 40: Total display

## 6.6 PLU call-up

PLU = **P**rice **L**ook **U**p

Article is displayed with price, text etc.

### Menu setting

- Define PLUs in PLU maintenance.

PLU call-up can take place according to three different procedures:

### 6.6.1 Direct PLU call-up



Direct access via PLU key, e.g. <PLU 1>.

### PLU call-up via second keyboard level



Level 2 is activated.

Direct access via PLU key, e.g. <PLU 1>.



Direct access via PLU key, e.g. <PLU 1>.

### 6.6.2 Indirect PLU call-up

#### Menu setting

- In configuration < Basic sales settings>, select **5363 / PLU No.**

#### Basic setting

- Select "Set", "Timeout" or "Enter" from the PLU Confirmation menu.



Enter PLU no.

PLU confirmation takes place after:

- Filling of PLU input places [set]
- Expiration of about 0.5 seconds [Timeout]
- the <Enter> key has been pressed.

### 6.6.3 Calling PLUs after switch-over

(unit price input/PLU input)

#### Menu setting

- In the <Basic sales settings> configuration, selection **5363 / PLU no.**

#### Basic setting

- Select "Unit price input" in the standard menu.
- Select "Set", "Timeout" or "Enter" from the PLU Confirmation menu.



Switch from unit price input to PLU input.



Enter PLU no.

PLU confirmation takes place after:

- Filling of PLU input places [set]
- Expiration of about 0.5 seconds [Timeout]
- the <Enter> key has been pressed.

### 6.6.4 PLU call-up without PLU text

Direct or indirect PLU call-up.



Direct access via PLU key, e.g. <PLU 1>.

The message "PLU without text" appears ①.

The article has been defined in the PLU maintenance without text.

PLU ohne Text			
	kg	EUR/kg	EUR
①	2,000	20,00	40,00

Illustration 41: PLU without text

### 6.6.5 PLU call-up with automatic PLU prefix.

#### Menu setting

- In the <Basic sales settings> menu configuration, selection **5363 / PLU no.**

#### Basic setting

- In "PLU input positions", enter 3 for example (3-digit PLU no.).
- Select "Set" in "PLU confirmation".
- In "Automatic PLU prefix No." enter the No.
- In the "PLU Prefix" menu in data maintenance, Select **2952**:
- "PLU Prefix Number:", enter the "Number sequence" and the "Display value".

## Operating procedure

 Enter PLU no.

PLU Prefix is displayed automatically <sup>①</sup>.

Automatic PLU prefix, e.g. 80

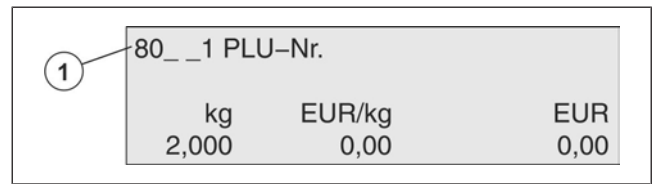





Illustration 42: Entering PLU

   Enter PLU no., e.g. 123.

The article is displayed once the PLU no. has been entered <sup>②</sup>.





Illustration 43: Entering PLU

## 6.7 Operating procedure after PLU call-up

PLU call-up [▶ 43].

### 6.7.1 PLU call-up and registration

 Press a PLU key, e.g. <PLU1>.

 Register using operator key, e.g. <OP1>.

### 6.7.2 Unit price input after PLU call-up

The <Unit price input> key has two functions. Unit price input after PLU call-up and unit price input without PLU call-up [▶ 47].



#### Menu setting

- In the "Prices" menu in data maintenance, **selection: 112/ Dept. no./ PLU no./ 1:** switch on "price overwrite".

⇒ Place article on the scale.

⇒ Call up PLU article.

 Press key <Unit price input> (depending on configuration).

   Enter new unit price, e.g. 20, 30.



 Register using operator key, e.g. <OP1>.

### 6.7.3 Register with unit price or selling price = 0.

#### Menu setting

- In the "Configuration"/"Basic Sales Setting" menu, selection **5 3 6 3**: Activate the "Sale with UP/SP price =0" menu item.
- In menu "PLU maintenance" / "Prices", select **1 1 2 / Dept. no. / PLU no. / 1**: Activate the "Price overwrite" menu item.
- In the "Data maintenance"/"Operator data" menu, selection **2 3 / Operator no.:** Select menu item "Price overwrite [PLU-dependent]".

⇒ Call up PLU article.



Press key <Unit price input>.

The Unit price is set to 0.00.

The article can be registered without a unit price or selling price. Quantity (kg) and number of pieces are recorded in reports.



Register using operator key, e.g. <OP1>.

### 6.7.4 Registering manual weight input (depending on country)

⇒ Call PLU product ("Weighed" product type).



Press key <Multiplication + Manual weight>.



Enter known weight, e.g. 1.500 kg.



Confirm input, display selling price



Register using operator key, e.g. <OP1>.

### 6.7.5 Multiplication of PLU piece-price article with predefined quantity

⇒ Call up PLU article (non-weighed, minus or by-count articles).



Press <Multiplication>.



Enter piece number, e.g. 22.



Register using operator key, e.g. <OP1>.

## 6.7.6 Multiplication of PLU price per piece with a partial number of pieces

A partial number of pieces is half a loaf of bread, for example.

### Menu setting

- In the "Define key" menu configuration, selection **5312**: Create key <, > or <.> (comma or full-stop, decimal point).
- In the "Prices" menu in PLU maintenance for non-weighed articles, selection **112/ Dept. no./ PLU no/ 1**: Select the "Non-weighed" PLU type and the "Normal price" price type.

### Sale of one partial piece

⇒ Call up PLU article (non-weighed article).



Press <Multiplication> key.



Enter partial number of pieces, e.g. 0.5 for half a loaf of bread.



Register using operator key, e.g. <OP1>.

### Sale of several partial pieces

⇒ Call up PLU article (non-weighed article).



Press <Multiplication>.



3 x 0.5 for three half loaves.



Register using operator key, e.g. <OP1>.

## 6.8 Operation procedure without PLU call-up

### Unit price input price/kg

⇒ Place article on the scale.



Press key <Unit price input> (depending on configuration).



Enter unit price, e.g. 8.50 price/kg.



Register using operator key, e.g. <OP1>.

### Unit price input price/100 g

⇒ Place article on the scale.



Press key <Unit price input>.



Switch from price/kg to price/100 g.



Enter unit price, e.g. 3.56 price/100g.



Register using operator key, e.g. <OP1>.

### Manual input price per piece



Press <Manual input> key.



Enter price per piece, e.g. 8.65.



Register using operator key, e.g. <OP1>.

### Multiplication of price per piece



Press <Manual input> key.



Enter price per piece, e.g. 8.65.



Press <Multiplication>.



Enter number of pieces, e.g. 5.



Register using operator key, e.g. <OP1>.

### Minus amount input



Press <Minus> key.



Enter change, e.g. 1.00 for returnable bottle.





Register using operator key, e.g. <OP1>.

### Multiplication of minus amount



Press <Minus> key.



Enter change, e.g. 1.00 for returnable bottle.



Press <Multiplication>.



Enter number of pieces, e.g. 5.



Register using operator key, e.g. <OP1>.

## 6.9 Product group sale by PLU

In this operating mode, the unit price of the PLU is set to "Zero" and can be entered directly (without needing the Price overwrite key).

### Menu setting

- In the "Prices" menu in PLU maintenance, selection **112/dept. no., PLU no./1**: Activate "Price overwrite".
- In the Texts menu in PLU maintenance, selection **112/ dept.no./ PLU no./ 2**: Create the PLU text, e.g. "Product group 1".

### Operating procedure

⇒ Place article on the scale.



Press a PLU key, e.g. <PLU1>

The product group text is displayed, unit price of the PLU is 0.00



Enter the unit price, e.g. 5.00.



Register using operator key, e.g. <OP1>.

## 6.10 Constant

Set the article and/or tare (depending on the configuration), e.g. for several consecutive sales of the same article.



Switch on constant function.

The word CONST. is lit up in the display.



Switch off the constant function again.

The lit word CONST. goes out.

## 6.11 Scroll function

After registering several articles (before total completion), the single articles can be displayed using the "Scrolling" function.



Open scroll function.



Press operator key, e.g. <OP1>.

Last item is displayed.



Scroll (n times), items are displayed in descending order.



Close scroll function.

## 6.12 Cancellation

Articles can be canceled before total completion.

### Menu setting

- In the "Data maintenance" / "Operator data", selection **2 3**: Create the operator with or without the right to execute cancellations.
- Activate or deactivate the "Print cancellation" menu item in the "Device configuration" / "General" menu, selection **5 3 2 1**.

### Immediate cancellation with or without operator's permission to cancel

Canceling immediately last sold article



Press <Cancellation> key.



Press operator key, e.g. <OP1>.

Last item is displayed and canceled.

If operator 1 does not have permission to cancel, a different operator with permission to cancel has to carry out the cancellation (e.g. operator 2).



Press operator key, e.g. <OP2>.

⇒ Enter password (of operator with permission to cancel).



Confirm entry.

The last item is canceled.

### Sheet cancellation with or without operator's permission to cancel

Several articles have already been sold. A specific article has to be canceled.



Open scroll or cancellation function.



Press operator key, e.g.<OP1>.

Last item is displayed.



Scroll until desired product appears in the display.



Press <Cancellation> key.

The item is canceled and is marked with an "S".

If operator 1 does not have permission to cancel, a different operator with permission to cancel has to carry out the cancellation (e.g. operator 2).



Press operator key, e.g.<OP2>.

⇒ Enter password (of operator with permission to cancel).



Confirm entry.

The last item is canceled.



Exit scroll or cancellation function.

## 6.13 Displaying subtotal

After registering one or more articles, the subtotal can be displayed briefly.

### Operating procedure

⇒ Register several PLUs.



Press <Subtotal> key.



Register using operator key, e.g. <OP1>.

Brief display of subtotal and item number.

## 6.14 Total

After registration of one or more articles, the total completion is issued.



Press the <Total> key.



Register and print using operator key, e.g. <OP1>.

Brief display of total and item number.

## 6.15 Tare

### 6.15.1 Tare balancing for unknown tare values

- An unknown tare (empties) is a non article-related tare. This tare has to be weighed and tared.
- The total weighing range can be tared (country-dependent).
- The tared value is subtracted from the total weighing range.
- If an unknown tare has been tared with the  key, it cannot be overwritten by a known tare (manual tare, fixed tare T1 - Tx or PLU tare). After a tare balance for an unknown tare, it is possible to call up the PLU with PLU tare, however the PLU tare is ignored.

### Tare balance (allow for tare of empties)

⇒ Place empties on the scales.



Press <tare> key.

Display of tare weight.

Weigh in empty article.

Display of tare and net weight.

### Stack tare (country-related)

⇒ Place empties on the scales.



Press <tare> key.

Display of tare weight.

Weigh in empty article.

Display of tare and net weight.



Press <tare> key.

Display of tare weight, etc.

## 6.15.2 Tare balancing with known tare

- When a packaged article is weighed, the tare weight must already be known (packaging/PLU-related tare).
- With multi-division scales, the known tare may only be within the smallest division range.
- After calling up a fixed tare (T1-Tx), or after entering a manual tare, these tares cannot be overwritten by a PLU tare (PLU tare is ignored).
- A PLU tare cannot be overwritten by a fixed tare (T1-Tx).
- A known (entered) tare cannot be overwritten with an unknown (weighed) tare. The known tare can be entered in 3 ways.

### 1. Manual tare

### 2. Allowing for a tare via the fixed tare key T1 - Tx

### 3. PLU tare

- In various countries manual tare is not allowed. Manual tare can be switched on or off in the service menu, under "Adjustment". This menu item can only be accessed when the balancing bridge of the ADC is closed.

After verification the manual tare may not be changed any more.

## Rounding rule for *known tare*

After entering and applying the tare value, the least significant display position is rounded automatically.

### Interval from 2 to 2 g

e.g.:

Weighing range                      6.000 kg

Interval                                0.002 kg

Odd tare value entries (1,3,5,7,9) in the least significant display position are generally rounded up (2,4,6,8,10).

### Display step from 5 to 5 g

e.g.:

Weighing range                      15.000 kg

Interval                                0.005 kg

Tare value input is rounded up or down in the least significant display position.

Input 1 or 2                            - Rounding off to 0

Input 3 or 4                            - Rounding up to 5

Input 6 or 7                            - Rounding off to 5

Input 8 or 9                            - Rounding up to 10

## Tare priority (only USA)

### Menu setting

- In menu "Configuration" / "Priority", select **5 3 6 3**: Set priority of article tare and fixed tare. The standard setting is "Fixed tare".

## Manual tare (country-related)

Scales on no load (weight display 0,000 kg).



Press <tare> key.



Enter a known tare value, e.g. 0.500 kg.



Confirm entry.

## Taring via fixed tare key T1 -Tx

### Menu setting

- In configuration, select **5312**: Define fixed tare key <T1> - <Tx>.
- In data maintenance/ tare fixed values, select **28**: enter known tare value.



Press fixed tare key <T1> (direct taring).

### 6.15.3 PLU tare

A tare value and/or tare % or tare no. can be entered for the PLU tare in the PLU maintenance. When calling up a PLU, the PLU tare is automatically activated and displayed [▶ 43]. Scales using tare values and scales using tare numbers can operate together in one system. In price labeling mode tare values are used and during sales, tare numbers are applied. Switching from a tare value to a tare number in the configuration should be managed via a function menu.

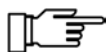

If a tare no. was assigned to a PLU not defined in data maintenance, the following error message appears: "Taring not ok".

## Clear Tare

Manual (depends on country):

Scale is not loaded.



Activate <Tare> key and the tare is erased immediately.

Automatically:

Scale is not loaded.

After successful registration, tare and unit price are deleted.

## 6.16 Normal ticket

Several articles plus total can be printed on a normal ticket. Department number and total, for example, are coded in the barcode.

### Menu setting

- Select "Assisted sale with ticket" in configuration in the operating mode menu; select: **5362**
- Select "Variable operator key" in the operating modes menu; select: **5361**
- Activate "Add customer total" in the printer menu; select: **5321**
- In menu Printer select "Print [item and total]", select: **53221**

### Operating procedure

⇒ Register one or several articles.



Press the <Total> key.



Register and print using operator key, e.g. <OP1>.

The ticket is printed.

### Print example: Normal ticket

- ① Department no. 00001
- ② Total, e.g. 029.17 EUR



Illustration 44: Normal ticket

## 6.17 Assisted sale with labels

Only **one PLU** can be printed on the label. PLU no. and selling price, for example, are coded in the barcode.

### Menu setting

Configuration:

- In menu Operating Mode select **5362**, "Assisted sale".
- In menu Operating Modes activate **5361**, "Price call-up Recording." and select "Fixed operator key".
- In the Printer menu, select **5321**, switch off "Add customer total".
- In menu Printer select **53221**, "Print [item]".

### Operating procedure

⇒ Place article on the scale.



Press a PLU key, e.g. <PLU1>.

Display of PLU text for approx. 1 second, followed by display of operator no. and item counter.

The label is printed.

## 6.18 Article with fixed volume and fixed price

With articles having an unknown price/liter, the price is calculated from the fixed volume, e.g. 0.75 l and the fixed price, e.g. EUR 2.00 and then printed.

### Menu setting

- In commissioning, switch on the Fixed weight menu, select **6311**
- Define article in the PLU maintenance, select **112/ Dept.No./ PLU No./ 1**  
In PLU type set "Fixed volume".  
Enter the fixed price in Unit price, enter the piece price and switch unit price calculation on or off.
- In the Tare+Weight+Quantity menu, select **112/ Dept.no./ PLU no./ 3**: Enter fixed volume, e.g. 0.750.  
Activate menu "Weight for fixed price PLU" if the volume should be printed on the standard label.

### Operating procedure

⇒ Call up article, e.g. 1 bottle of juice 0.75 l.

⇒ Display of fixed volume, e.g. 0.75 l and fixed price, e.g. 2.00 EUR.

⇒ With unit price calculation, price/liter appear in the display.



The price can be overwritten.





Multiplication with quantity input is supported.



Register using operator key, e.g. <OP1>.

## 6.19 PLU with data of origin

When beef is sold the customer should be given information about the origin of the meat. Beef is marked with a traceability number which is entered or scanned when sold. The abbreviated traceability number refers to the ident no., which allows traceability of the origin.

Data of origin are printed on the ticket or label in the operating mode Assisted Sales, Price Labeling, Delivery Note and Cash Invoice. The data are not printed for Inventory, Purchase Order and Return Delivery

There are two possible operating procedures for PLUs with data of origin:

- Manual input of abbreviated traceability number
- Abbreviated traceability number from configuration

### 6.19.1 Sale with manual input of abbreviated traceability number

When calling up an article (PLU) with origin data, one field is displayed for the abbreviated traceability number and a second field is displayed for the ID number. After entering the traceability no. (e.g. 12), the data of origin appears as defined in the format template, "Sales display".

#### Menu setting

- In Commissioning, in the "Other" menu, define the data of origin and the traceability report. Select **6 3 7**
- In the configuration, in the "Basic Sales Settings" menu, define the data of origin without abbreviated traceability number, select **5 3 6 3 / Data of origin:**  
Switch on "Data of origin active", switch on "Modification of data permitted", switch on "Extended display".  
In the "Ticket" and "Label" menus, switch "Print data of origin" on or off, selection **5 3 2 2 / 2 ticket** and selection **5 3 2 2 / 4 label**.
- Define the "Data of origin" in data maintenance and create the format template for the ticket or label and sales display in "Format template".  
Create conversion tables, select **2 9 6 Sales Tables**  
Create format templates, select **2 9 6 Format Templates** or select **2 2 6 2**  
Data of Origin. Select **2 9 6 abbreviated traceability number**  
Activate "Print data of origin", select **2 9 6 Abbreviated traceability no.**
- In PLU maintenance, from menu "Define PLU" "Print options" in "Data of origin" select [man.input] and "Format template for origin" 1, 2, 3, 4 or 5, select **1 1 2 / Dept.no. / PLU no. / 7**.

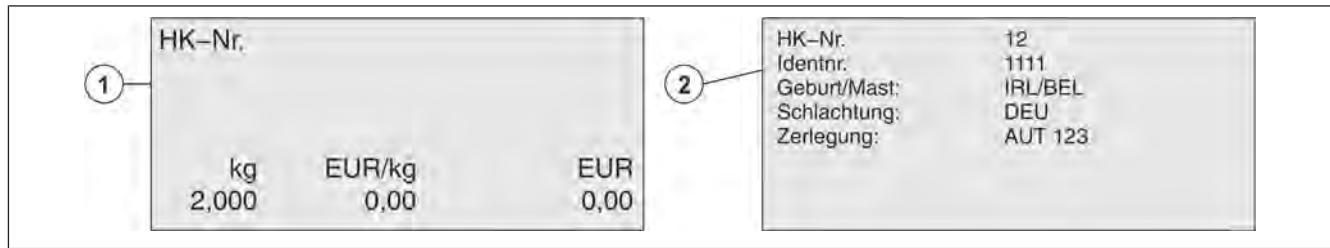

Illustration 45: Display and extended display

- ① Display
- ② extended display

## Operating procedure

⇒ Place beef on the scale.



Press PLU key, e.g. <PLU1> (beef).

Display PLU text and, depending on the menu setting, the last traceability no.



With key <Esc> PLU can be deleted.



Confirm or enter last traceability no., e.g. 12 and press <Enter> key.

The PLU text is displayed again.



Register using operator key, e.g. <OP1>.

The sold quantity is booked in the traceability data sales report.



Press the <Total> key.



Register using operator key, e.g. <OP1>.

The ticket is printed with the PLU text and data of origin. Depending on the menu setting, negative quantities on the ticket are printed without data of origin.

## Changing data of origin

If data of origin have to be changed, this can be handled directly after calling up the traceability number.



Press PLU key, e.g. <PLU1> (beef).

Display PLU text and, depending on the menu setting, the last traceability no.



Confirm the last traceability number or enter the traceability number, e.g. 12

PLU text and data of origin are displayed.



Using the arrow keys, go to the Data of origin menu of the traceability number, e.g. 12



Go to the field to be modified using the arrow keys in the menu.

⇒ Enter new data, e.g. change country of birth from "IRL" to "DEU".



Press <Enter> key.



Save using the <Esc> key



back to display with <Mod> key without saving.



Register and print using operator key, e.g. <OP1>.

## 6.19.2 Sale with abbreviated traceability number from configuration

### Menu setting

- In Commissioning, in the "Other" menu, define the data of origin and the traceability report, select **6 3 7**
- Define the data of origin with abbreviated traceability number in configuration in the "Basic sales settings" menu, select **5 3 6 3 / Data of origin:**  
Switch on "Data of origin active".  
In the "Ticket" and "Label" menus, switch "Print data of origin" on or off, selection **5 3 2 2 / 2 ticket** and selection **5 3 2 2 / 4 label**.
- Define the "Data of origin" in data maintenance and create the format template for the ticket or label and sales display in "Format template".  
Create conversion tables, select **2 9 6 Conversion tables**.  
Create conversion tables, select **2 9 6 Format Templates** or select **2 2 6 2**.  
Create data of origin, select **2 9 6 Abbrev. Origin No.**
- In PLU maintenance, from menu "Define PLU" "Print options" in "Data of origin" select [man.input] and "Format template for origin" 1, 2, 3, 4 or 5. Select **1 1 2 / Dep.no. / PLU no. / 7**

### Operating procedure

⇒ Place beef on the scale.



Press PLU key, e.g. <PLU1> (beef).

Display PLU text and automatic call-up of data of origin from the abbreviated traceability number without displaying the abbreviated traceability number.



Register using operator key, e.g. <OP1>.

The sold quantity is booked in the traceability data sales report.



Press the <Total> key.



Register and print using operator key, e.g. <OP1>.

The ticket is printed with the PLU text and data of origin.

## 6.20 Self-service mode

### Menu setting

- Select "Self service mode" in configuration in the Operating mode menu.
- In menu Operating Modes activate "Price call-up & Recording." and select "Fixed operator key".
- Switch off "Addition customer total" in the Printer menu and select "Print [Item]".

### Operating procedure

- Place article on the scale.
- Activate the relevant PLU key.
- The PLU text is displayed briefly.
- The label is printed.
- Remove the article from the scale.

### Multiplication in self-service mode

Manual articles can be multiplied in self-service mode.

### Operating procedure

**A manual article (e.g. mustard), PLU no. 123 has to be sold five times:**



Press <Multiplication>.



Enter number of mustard (5).



Confirm entry.



Enter PLU no., the article is registered and the label is printed.

If the manual article (e.g. mustard) is assigned to a direct PLU key e.g. <PLU11>, the following procedure must be followed:



Press <Multiplication>.



Enter number of mustard (5).



Press "PLU key <PLU11> and the article is registered and the label is printed.

## 6.21 Cash register functions

### Menu setting

- In the configuration activate "Pay-in/pay-out mode" in the Cash Register menu and depending on requirements, activate further cash register menus on or off. **Select 5 3 4.**
- Select "Cashier" from the Operator data menu in Data maintenance.

### Operating procedure

⇒ Register PLU.



Press the <Total> key.



Register using operator key, e.g. <OP1>.



Return to sale.

or



At exact amount press <Enter> key.

The ticket is printed and the cash drawer opens.

Zu bezahlen:	24,33 EUR
Gegeben:	0,00 EUR

Illustration 46: Amount due

Zu bezahlen:	24,33 EUR
Gegeben:	24,33 EUR
Zurück:	0,00 EUR

Illustration 47: Right amount tendered

If the customer gives another amount, enter the current amount, e.g. 50.00 EUR.



Delete incorrect input and enter new amount.

### For inputs of "Amount tend." smaller than "Amount due", e.g. EUR 20.00:



Press <Enter> key.

Amount due ①.

Zu bezahlen:	4,33 EUR
Gegeben:	0,00 EUR
Bisher gegeben:	20,00 EUR

Illustration 48: Amount still due



Press <Enter> key.

Zu bezahlen:	4,33 EUR
Gegeben:	4,33 EUR
Zurück:	0,00 EUR

Illustration 49: Remaining amount given

## 6.22 Sale of articles with different price types

### Menu setting

- In the "Database configuration" menu, determine the number of "Supplementary PLU data" for the price types "Price grad.", "Free", "n\*quantity grad.", "n\*amount grad.", "Percentage grad.", "Amount grad.", "Mix. special price". Select **6 3 1 1**.
- In the "PLU Maintenance" menu, define the article including the price type: "Normal price", "Price grad.", "Free", "n\*quantity grad.", "n\*amount grad.", "Percentage grad.", "Amount grad.", "Mix. special price", "Price groups" or "Extra price". Select **1 1 2 / Dept.no. / PLU no. / 1**.

The article is sold at the same price, independent of the quantity or piece number.

### Graduated price

#### Example: PLU type "Weighed"

The unit price of ground meat is e. g. 11.00 EUR/kg. There is a price graduation by weight.

#### Example: PLU type "Non-weighted"

The unit price for "pepper salami" is, for example, EUR 6.00 EUR/piece. The price graduation is according to piece number.



Normal price, price grad. and the difference in amount are printed plus a supplementary text on freely-programmable labels and on tickets, e.g. "You can save EUR 1.00".

### N/C

#### Example: PLU type "Weighed"

The unit price of ground meat is e. g. 11.00 EUR/kg. In the event of large quantities, the price is reduced by a free-of-charge weight.

#### Example: PLU type "Non-weighted"

The unit price for "pepper salami" is, for example, EUR 6.00 EUR/piece. The price is made cheaper by a free number of pieces.

If free of charge, the PLU piece price can be multiplied by a partial piece number [▶ 47].

### 6.22.1 n\*quantity grad.

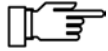

Observe the menu settings [▶ 62].

---

n\*quantity grad. is only supported for the PLU type "Weighed".

A specific proportion of weight of no charge (weight advantage) needs to be calculated from a specifically entered weight value (threshold).

If the threshold value repeats itself, the limit of the weight advantage is correspondingly increased in terms of the entered value.

#### Example:

When customer buys something greater than 0.300 kg, he is given 0.050 kg free of charge. If customer purchases 0.600 kg, he is given 0.100 kg free of charge, etc.

#### Operating procedure

⇒ Place product on scale.

⇒ Call up PLU.



Register using operator key, e.g. <OP1>.

The "weight advantage" appears on the display with the corresponding negative amount.



Press the <Total> key.



Register and print using operator key, e.g. <OP1>.

A note, "weight advantage" including the corresponding weight, unit price, and negative selling price is printed on the ticket.

### 6.22.2 n\*amount grad.

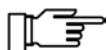

Observe the menu settings [▶ 62].

---

n\*amount grad. is only supported for the PLU type "weighed".

A graded amount discount should be calculated based on the sales price and from a specifically entered weight value (threshold).

If the threshold value repeats itself, the limit of the graded amount is increased by the entered value.

#### Example:

When buying 0.300 kg, customer is granted a discount of 0.50 EUR. If he buys 0.600 kg, he is granted a discount of 1.00 EUR etc.

## Operating procedure

⇒ Place product on scale.

⇒ Call up PLU.



Register using operator key, e.g. <OP1>.

The "price advantage" appears on the display with the corresponding negative amount.



Press the <Total> key.



Register and print using operator key, e.g. <OP1>.

The note "discount" with the corresponding negative amount is printed on the ticket.

### 6.22.3 Percent graduation



Observe the menu settings [► 62].

Percent graduation is only supported for the PLU type "weighed".

A percentage-based discount is calculated for the selling price from a predefined weight value (threshold). You can enter five threshold values.

#### Example:

For purchases of more than 0.300 kg the customer is given a 1% percent graded discount, for more than 0.500 kg 6% and more than 1.000 kg 10%.

## Operating procedure

⇒ Place product on scale.

⇒ Call up PLU.



Register using operator key, e.g. <OP1>.

The "price advantage" appears on the display with the corresponding negative amount.



Press key <Total>.



Register and print using operator key, e.g. <OP1>.

The note "discount" with the corresponding negative amount is printed on the ticket.

### 6.22.4 Amount graduation



Observe the menu settings [► 62].

Amount graduation is only supported for the PLU type "weighed".



A graded amount discount should be calculated based on the sales price and from a specifically entered weight value (threshold). You can enter five threshold values.

### Example:

When the customer makes a purchase greater than 0.300 kg, he/she is given a scaled amount discount of EUR 0.50; from 0.500 kg the discount is EUR 1.00; and from 1.000 kg EUR 2.50.

### Operating procedure

⇒ Place product on scale.

⇒ Call up PLU.



Register using operator key, e.g. <OP1>.

The "price advantage" appears on the display with the corresponding negative amount.



Press the <Total> key.



Register and print using operator key, e.g. <OP1>.

The note "discount" with the corresponding negative amount is printed on the ticket.

## 6.22.5 Mix. special price



Observe the menu settings [▶ 62].

Mix. special price is only supported for the PLU type "weighed".

In the event of larger piece numbers, a free number of pieces is granted, which is identified as a free weight in relation to the weight per piece (average weight).

### Example:

In PLU maintenance, for example, the information: from 10 pieces/2 pieces are free is entered.

In a sale, the pieces are weighed and the number of pieces is entered.

This produces an average value for weight.

If the number of pieces entered (here from 10 pieces) is within the "free" range, the free piece number is multiplied by the average weight value and identified as the free weight.

### Operating procedure

⇒ Place product on scale, e.g. 10 hamburgers.



Press PLU key for "hamburger", e.g. <PLU1>.



Open piece number input.



Enter number of pieces, e.g. 10.



Confirm entry.



Register using operator key, e.g. <OP1>.



Press the <Total> key.



Register and print using operator key, e.g. <OP1>.

A note, "weight advantage" including the corresponding weight, unit price, and negative selling price is printed on the ticket.

## 6.23 Obligatory input for piece price for piece-price articles

Piece price articles are the PLU types: non-weighed, manually weighed and manual fixed weight. The number of pieces has to be entered to register the PLU.

### 6.23.1 Mandatory entry per PLU

After opening the piece-price article, the number of pieces has to be entered. Also for piece number = 1. Compulsory input can be switched on or off for each PLU in the "PLU maintenance" menu.

#### Menu setting

- In menu "PLU maintenance" / "Prices" activate menu item "Mandatory input number of pieces", select **1 1 2 / Dept.No. / PLU No. / 1**.

#### Operating procedure

⇒ Call up number piece-price article.

"Please enter number of pieces" appears in the display, alternating with the PLU text.



Enter number of pieces.



Register using operator key, e.g. <OP1>.

### 6.23.2 Obligatory input always

After opening the piece-price article, the number of pieces has to be entered. Even if the number of pieces = 1.

#### Menu setting

- In menu "Configuration" / "Basic sales settings" select menu item "Mandatory input [always for piece]", select **5 3 6 3**.

## Operating procedure

⇒ Call up number piece-price article.

"Please enter number of pieces" appears in the display, alternating with the PLU text.



Enter number of pieces.



Register using operator key, e.g. <OP1>.

### 6.23.3 Obligatory input limited

After opening the piece-price article, the number of pieces has to be entered. Registration takes place immediately for piece number = 1.

#### Menu setting

- In menu "Configuration" / "Basic sales settings" select menu item "Mandatory input [limited]", select **5 3 6 3**.

#### Operating procedure when number of pieces = 1.

⇒ Call up number piece-price article.

"Please enter number of pieces" appears in the display, alternating with the PLU text.



Register using operator key, e.g. <OP1>.

#### Operating procedure when number of pieces > 1

⇒ Call up number piece-price article.

"Please enter number of pieces" appears in the display, alternating with the PLU text.



Enter number of pieces.



Register using operator key, e.g. <OP1>.

### 6.24 Input of number of bags obligatory

This function is used to print the number of bags on the ticket.

During a sale, after pressing the <Total> key, the number of bags has to be entered.

#### Menu setting

- In data maintenance in menu "General texts" create the text, e.g. "Number of bags".
- In menu "Header and footer texts" create macros "Packaging text" and "Number of packagesNumber of packages".
- In the configuration in menu "Prompting/texts" "With packaging text" enter greater 0.

### Operating procedure

- ⇒ Register PLU.
- ⇒ Press key <Total>.
- ⇒ Enter number of bags, e.g. 3.

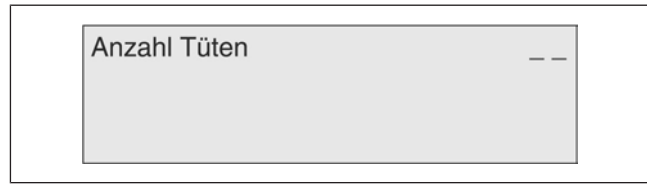

Illustration 50: Number of bags



Register with operator key, e.g. <OP1>

The ticket is printed with the text "Number of bags" and the number of bags, e.g. 3.

## 6.25 Sale with weight-fixed-price article

Weight fixed-price articles are articles of the type "Manual weighed", "By-count", "Manual fixed weight", "By-count fixed weight" and "By-count weighed".

The established weight is always transferred to all sales memories of the individual reports (e.g. PLU, product group report, etc.).

If unit price back calculation is activated, the unit price is calculated according to the price basis (price/kg or price/100 g) from selling price and weight.

### 6.25.1 PLU type: "Manual-weighed"

#### Menu setting

- PLU maintenance, select **112/ Dept.no./ PLU no./ 1:**. Select the PLU type "Manual W" and switch "Unit price return account" either on or off.
- In the configuration in the Printer menu select **53221:**, activate "Weight for fixed price PLU" with or without weight printout.

### Operating procedure

- ⇒ Place the weight-fixed-price article on the scales.



Call up the "Manual-weighed" article, e.g. PLU 1

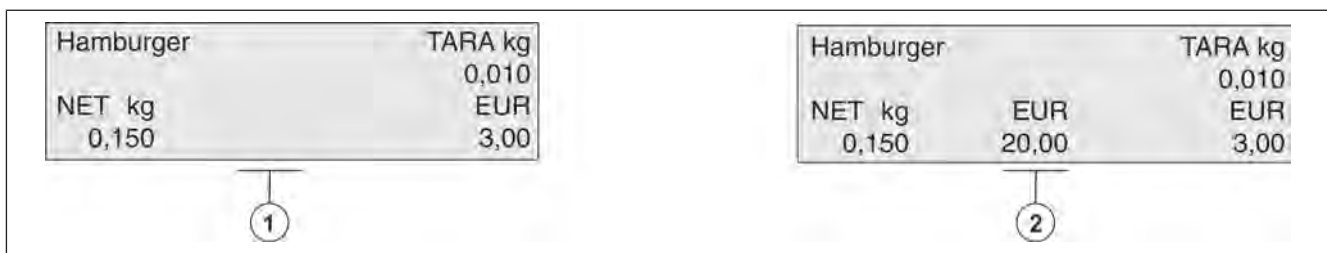

Illustration 51: Article: "Manual-weighed"

Supported by PLU tare

- ① Display without unit price return account
- ② Display with unit price return account



The selling price can be overwritten.



Multiplication is supported.

Place weight-fixed-price article on the scale, e.g. 5 articles.



Enter number of pieces, e.g. 5.



Register with operator key, e.g. <OP1>

- ① Weight of the 5 weight-fixed-price articles
- ② Display of number of pieces, and calculated unit price can be printed on label.
- ③ Calculated selling price  $5 \times 3.00 = 15.00$

Stückzahl eingeben		TARA kg
NET kg	STK	0,010
0,762	5	EUR
		15,00
①	②	③

Illustration 52: Example display

### 6.25.2 PLU type: "By-count weighed"

#### Menu setting

- PLU maintenance, select **112/ Dept.no./ PLU no./ 1**: Set PLU type to "By-count G" and switch "Unit price return account" on or off.
- In the configuration in the Printer menu select **53221**:and activate "Weight for fixed price PLU" with or without weight printout.

#### Operating procedure

➔ Place weight fixed price article onto scale, e.g. packaging with 10 eggs.



Call up article "By-count weighed", e.g. PLU 2.

Packung Eier		TARA kg
NET kg	STK	0,100
0,615	10	EUR
		3,00

Illustration 53: By-count weighed

Supported by PLU tare.

Supported with or without unit price return account.

Calculated unit price (e.g. 5.06 EUR/kg) is not displayed but printed on the label.



The selling price can be overwritten.



Multiplication is supported.

Place weight-fixed-price article onto scale, e.g. packaging with 15 eggs.



Enter number of pieces, e.g. 15.



Register using operator key, e.g. <OP1>.

Stückzahl eingeben		TARA kg
NET kg	STK	0,100
0,890	15	EUR 4,50

Illustration 54: Enter Number of pieces

### 6.25.3 PLU type: "Manual fixed weight"

Only supported in price labeling mode (country-specific).

#### Menu setting

- In configuration, activate "Price Labeling" in the Operating mode menu and "Weight for fixed price PLU" either with or without weight printout in the Printer menu.
- In PLU maintenance, enter the PLU type "Manual FW" and the fixed weight in "Tare +Weight". Switch "Unit price return account" on or off.

#### Operating procedure

① Without unit price return calculation

② Price labeling

② Call up the "Manual fixed weight" article, e.g. <PLU 2>.

Hamburger			
FESTWERTE			
kg		PA	EUR
0,150			3,00

①                      ②

Illustration 55: Without unit price return calculation

③ With unit price return calculation

④ Price labeling

④ The selling price can be overwritten.

④ Multiplication is supported.

Hamburger			
FESTWERTE			
kg	EUR/kg	PA	EUR
0,150	20,00		3,00

③                      ④

Illustration 56: With unit price return calculation

③ Enter number of pieces, e.g. 3.

Fixed weight and selling price correspond to 3 pieces ⑤.

① Register with operator key, e.g. <OP1>

Stückzahl eingeben			
FESTWERTE			
kg	STK	PA	EUR
0,450	3		9,00

⑤

Illustration 57: Enter Number of pieces

### 6.25.4 PLU type: "By-count fixed weight"

#### Menu setting

- In configuration, activate "Price Labeling" in the Operating mode menu and "Weight for fixed price PLU" either with or without weight printout in the Printer menu.
- In PLU maintenance, enter the PLU type "By-count FW" and the fixed weight in "Tare +Weight". Switch "Unit price return account" on or off.

#### Operating procedure



Call up the "By-count fixed weight" article, e.g. <PLU 2>.



Price labeling

Calculated unit price (e.g. 5.00 EUR/kg) is not displayed but printed on the label.



The selling price can be overwritten.



Multiplication is supported.



Enter number of pieces, e.g. 5.

Fixed weight and selling price correspond to 5 pieces ②.



Register using operator key, e.g. <OP1>.

Packung Eier			
FESTWERTE			
kg	STK	PA	EUR
0,600	10		3,00

①

Illustration 58: By-count-Fixed weight

Stückzahl eingeben			
FESTWERTE			
kg	STK	PA	EUR
0,300	5		1,50

②

Illustration 59: Enter Number of pieces

### 6.26 PLU type: "By count"

By-count PLUs are piece articles with a saved number of pieces. The selling price relates to the number of pieces. The number of pieces is calculated and printed on labels when "Unit price return calculation" is activated.

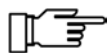

Adjustable first rounding for By-count in the "Country currency" menu.

Select **2 9 1 1**

#### Menu setting

- In menu "PLU maintenance" / "Prices" select menu item "PLU type [By-count]".
- Enter the quantity in the "Piece number" menu. Activate the "Price overwrite" menu item. Activate the "Unit price return calculation" menu item. Select **1 1 2 / Dep. No. / PLU No. / 1**

### Overwriting of number of pieces



Call up the "By-count" article, e.g. <PLU 7>.

Selling price/10 pieces ①.



The quantity can be overwritten.

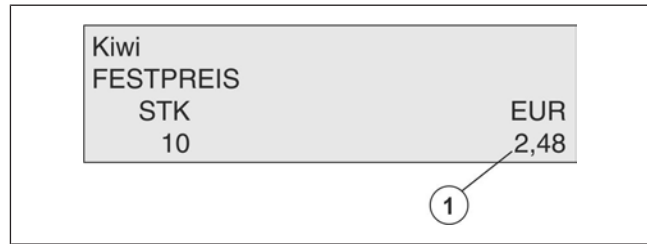

Illustration 60: Calling up "By-count"



Enter new quantity.

Selling price/15 pieces ②.

The piece price is calculated but not displayed.

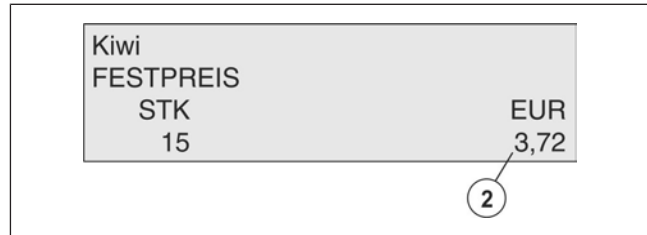

Illustration 61: Entering a new quantity



Register using operator key, e.g. <OP1>.

The calculated piece price is printed on the label with 4 decimal places ③.

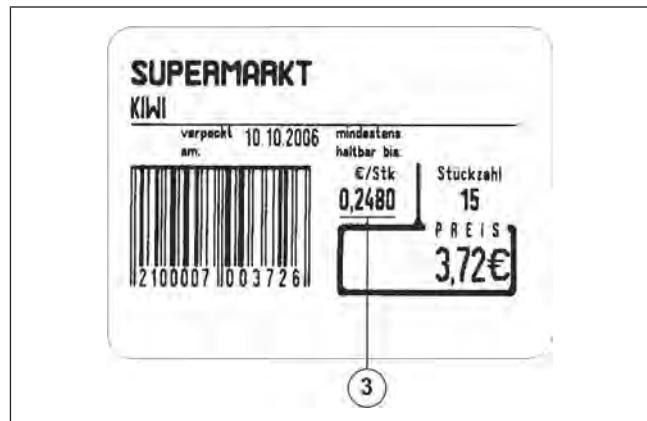

Illustration 62: Label with piece price

### Overwriting of the selling price



Call up the "By-count" article, e.g. <PLU 7>.

Selling price/10 pieces ①.



The selling price can be overwritten.



Illustration 63: Calling up "By-count"





Enter new selling price.

Overwritten selling price ②.

The piece price is calculated but not displayed.

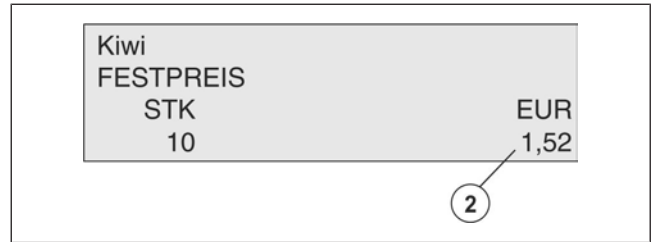

Illustration 64: Entering a new selling price



Register using operator key, e.g. <OP1>.

The calculated piece price is printed on the label with 4 decimal places ③.

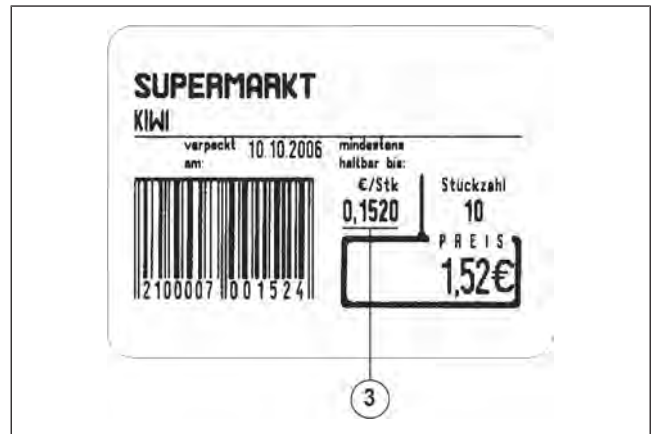

Illustration 65: Label with piece price

### Overwriting of selling price and quantity

From a defined number of pieces, calculations are based on a different selling price.



Call up the "By-count" article, e.g. <PLU 7>.

Selling price/10 pieces ①.



The selling price can be overwritten.



Illustration 66: Calling up "By-count"



Enter new selling price. ②.



The quantity can be overwritten.



Enter new quantity.

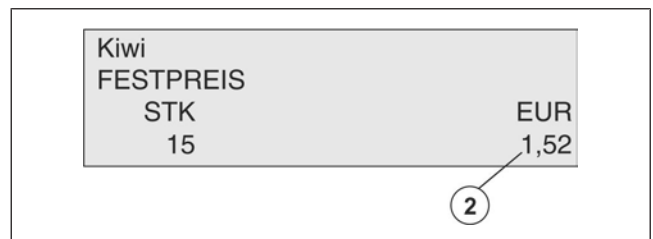

Illustration 67: Entering new values

Calculated selling price new selling price x new number of pieces.



Register using operator key, e.g. <OP1>.

The calculated piece price is printed on the label with 4 decimal places ③.

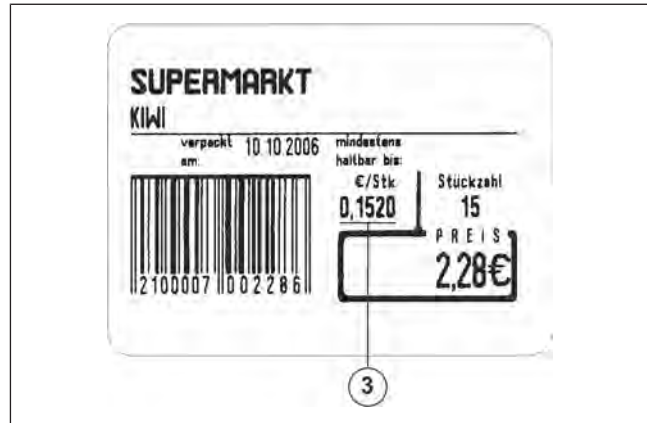

Illustration 68: Label with piece price

### Overwriting of number of pieces and selling price

Input of a definitive selling price for a defined number of pieces.



Call up the "By-count" article, e.g. <PLU 7>.



The quantity can be overwritten.



Enter new quantity.



The selling price can be overwritten.



Enter final selling price.



Final selling price ②.



Illustration 69: Calling up "By-count"

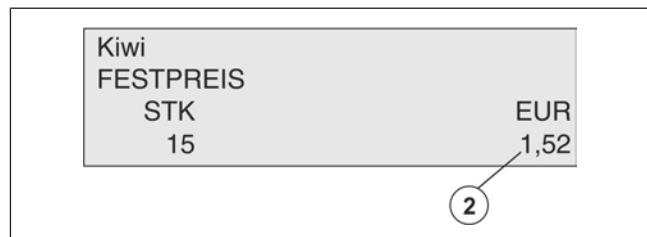

Illustration 70: Entering new values



Register using operator key, e.g. <OP1>.

The calculated piece price is printed on the label with 4 decimal places ③.

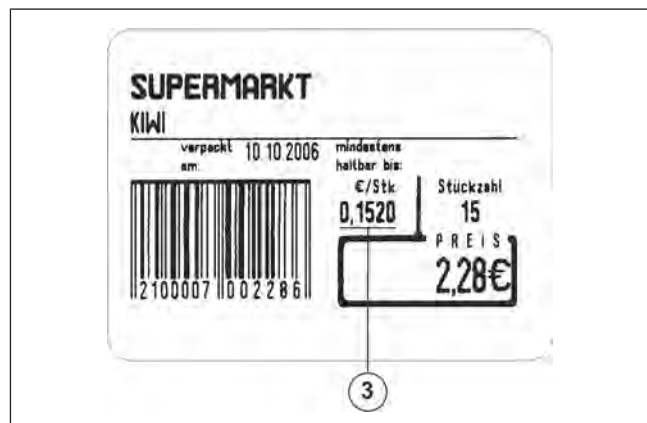



Illustration 71: Label with piece price



# 7 Troubleshooting

## 7.1 Fault description

Fault	Cause	Elimination
Display does not illuminate.	<ul style="list-style-type: none"> <li>– No supply voltage.</li> </ul>	<ul style="list-style-type: none"> <li>– Check and insert power cable.</li> <li>– Switch on mains switch.</li> </ul>
Display does not illuminate.	<ul style="list-style-type: none"> <li>– incorrect display settings for brightness, contrast.</li> </ul>	<ul style="list-style-type: none"> <li>– Reset display settings.</li> </ul> <p>Confirm key sequence:</p> 
Weight value display not at zero or modified.	<ul style="list-style-type: none"> <li>– Load plate not correctly positioned or objects located on the load plate.</li> <li>– Soiling on or beneath the load plate.</li> <li>– Scale not leveled.</li> </ul>	<ul style="list-style-type: none"> <li>– Clean load plate, position correctly and remove objects.</li> <li>– Level scale.</li> <li>– Switch device on/off.</li> </ul>
Printer will not print.	<ul style="list-style-type: none"> <li>– Print bar is open.</li> </ul>	<ul style="list-style-type: none"> <li>– Close print bar correctly.</li> </ul>

## 7.2 Messages

Test messages are listed in alphabetical order in the following table including cause and possible error rectification.

Text message	Cause	Remedy
Attention!! Scales switched off, please switch on!	<ul style="list-style-type: none"> <li>– Scales are not activated.</li> </ul>	<ul style="list-style-type: none"> <li>– Switch on all scales.</li> <li>– Insert connection cable and check.</li> </ul>
Attention! Scales are switched off!	<ul style="list-style-type: none"> <li>– Appears when the "Reports" menu is selected. One or more scales are not switched off.</li> </ul>	<ul style="list-style-type: none"> <li>– Switch on all scales.</li> <li>– Check cabling.</li> </ul>
Not in tare range	<ul style="list-style-type: none"> <li>– Appears during sales.</li> <li>– During taring attempt scales were in underload range.</li> </ul>	<ul style="list-style-type: none"> <li>– Unload scales, reset and retare.</li> </ul>
Evaluation active on another station	<ul style="list-style-type: none"> <li>– Appears if the same report is started on several devices.</li> </ul>	<ul style="list-style-type: none"> <li>– Wait until the report is completed on other devices.</li> </ul>

Text message	Cause	Remedy
Evaluation active on another scale	<ul style="list-style-type: none"> <li>– Appears when printing out a report.</li> <li>– A printout of the same report has been started at another set of scales.</li> <li>– Evaluation of the same report has been started via EDP.</li> </ul>	<ul style="list-style-type: none"> <li>– Wait until the report has finished printing out. Restart the report.</li> <li>– Wait until the report has been transmitted to the EDP. Restart the report.</li> </ul>
Operator is not a cashier!	<ul style="list-style-type: none"> <li>– The SC II is operated with the setting "Configuration" / "Cash desk" / "Amount tend./change op." YES. Finishing the ticket via the "Total" key on this SC II is only permitted for operators who have been defined as cashiers.</li> </ul>	<ul style="list-style-type: none"> <li>– In the "Data maintenance" / "Operator data" menu, check the settings for the applicable operator.</li> </ul>
Please log on cashier	<ul style="list-style-type: none"> <li>– Appears in cash register mode. Message when working with login/logoff at the SCII but no cashier is logged in.</li> </ul>	<ul style="list-style-type: none"> <li>– Log on cashier. "Operator log on/off" key</li> <li>– Check the set values of the operator used in "Data maintenance" / "Operator data". The "Cashier" setting should be active.</li> </ul>
Please apply article	<ul style="list-style-type: none"> <li>– Appears when self-service mode is activated.</li> </ul>	<ul style="list-style-type: none"> <li>– Position the article on the scale</li> </ul>
Please press key	<ul style="list-style-type: none"> <li>– Appears when self-service mode is activated.</li> </ul>	<ul style="list-style-type: none"> <li>– Press the button</li> </ul>
Code structure not defined	<ul style="list-style-type: none"> <li>– Appears when an article is being scanned with a code digit (e.g. 21..... ) that refers to a code structure number that is not defined in the "Data maintenance" / "Code structures" menu.</li> </ul>	<ul style="list-style-type: none"> <li>– Correct code digit or define a code structure to correspond to the code digit in the "Data maintenance" / "Code structures" menu.</li> </ul>

Text message	Cause	Remedy
Encoding of negative value	<ul style="list-style-type: none"> <li>– Appears if an attempt is made to encode a negative value in a barcode.</li> </ul>	<ul style="list-style-type: none"> <li>– Negative values cannot be encoded in a barcode. If you want to call up a PLU with a negative unit price, use the piece number code.</li> </ul>
<p>The text is XXX characters too long !</p> <p>The text was not saved !</p>	<ul style="list-style-type: none"> <li>– Appears in the PLU maintenance when entering PLU text.</li> </ul>	<ul style="list-style-type: none"> <li>– Shorten and save PLU text. The maximum value is 500 characters / 20 lines.</li> <li>– The two messages appear one after the other.</li> </ul>
<p>The text is XXX characters too long !</p>	<ul style="list-style-type: none"> <li>– Appears in cash register mode.</li> </ul>	<ul style="list-style-type: none"> <li>– Check the values for the foreign currency used in "Data maintenance" / "Foreign currencies".</li> <li>– Check the programming of the keyboard. "Data maintenance" / "Foreign currencies" / "Foreign currency key"</li> </ul>
<p>The PLU has not been defined.</p>	<ul style="list-style-type: none"> <li>– Appears when defining ranges.</li> <li>– The selected PLU has not been defined</li> </ul>	<ul style="list-style-type: none"> <li>– Enter the correct PLU no.</li> <li>– Create product.</li> </ul>
<p>Printer not set correctly!</p> <p>Switch device on/off, continue with &lt;Enter&gt; key</p>	<ul style="list-style-type: none"> <li>– Appears if adjustment has not been correctly performed during the self-adjustment process on the printer, e.g.: no paper inserted, end of paper during adjustment.</li> </ul>	<ul style="list-style-type: none"> <li>– After switching off/on, the adjustment process is automatically repeated.</li> </ul>
<p>EDP connection not available !</p>	<ul style="list-style-type: none"> <li>– Appears during continuous ticket call by EDP.</li> </ul>	<ul style="list-style-type: none"> <li>– Check connection cable from SC II to PC.</li> <li>– Check PC connection.</li> </ul>
<p>Incorrect check digit</p>	<ul style="list-style-type: none"> <li>– Appears when scanning a PLU.</li> </ul>	<ul style="list-style-type: none"> <li>– Check barcode print format for dot omissions.</li> <li>– If the EAN no. was entered manually via the keyboard, check the entry.</li> </ul>

Text message	Cause	Remedy
Incorrect price group!	<ul style="list-style-type: none"> <li>– Appears if a second price group is to be used within a ticket that has been opened with a defined price group. This is not allowed.</li> </ul>	<ul style="list-style-type: none"> <li>– Another price group cannot be selected within a ticket. Conclude ticket and process new ticket with corresponding price group.</li> </ul>
Incorrect range type, delete range	<ul style="list-style-type: none"> <li>– Appears when defining ranges/sets of PLUs.</li> </ul>	<ul style="list-style-type: none"> <li>– The applied number has already been assigned by a range or PLU set. Select free no.</li> </ul>
Wrong password	<ul style="list-style-type: none"> <li>– Appears during operator log on/log off.</li> </ul>	<ul style="list-style-type: none"> <li>– The used password is incorrect. Enter correct password. The password can be read out in "Data maintenance" / "Operator data" under the relevant operator number. When printing the operator list, the password is <b>not</b> printed.</li> </ul>
Error in encoding	<ul style="list-style-type: none"> <li>– Appears when printing barcodes.</li> </ul>	<ul style="list-style-type: none"> <li>– Check in "Data maintenance" in the "Barcode data" menu, that the settings for the applied barcode are correct.</li> </ul>
Error accessing the cash drawer	<ul style="list-style-type: none"> <li>– Cash drawer does not open. Read-back contact not detected.</li> </ul>	<ul style="list-style-type: none"> <li>– Check connector for SC II cash drawer.</li> </ul>
Zero setting error	<ul style="list-style-type: none"> <li>– Appears during sales. Error in automatic zero point control Scale is above the country-specific permissible automatic zero setting range.</li> </ul>	<ul style="list-style-type: none"> <li>– Clean load plate, position correctly and remove objects.</li> <li>– Switch scale off/on.</li> </ul>
Invalid fixed weight	<ul style="list-style-type: none"> <li>– Appears during sales. Fixed weight PLUs cannot be used in the price labeling mode.</li> </ul>	<ul style="list-style-type: none"> <li>– Check the PLU data for the called PLU in PLU maintenance.</li> </ul>

Text message	Cause	Remedy
<p>Selected operator key is already assigned to Operator X Select another key.</p>	<p>– Appears during sales during operator log on/log off.</p>	<p>– The selected operator key is already being used by another operator. Another operator key can be directly actuated and the operator is then logged on to this key.</p>
<p>Apply weight</p>	<p>– Appears during sales.</p>	<p>– Registration is only performed for a weight-dependent PLU after a load change.</p>
<p>Simultaneous evaluation on a number of scales is not permitted !!!</p>	<p>– Appears for reports, if the same cash reg. (POS) reports are being evaluated on a number of scales.</p>	<p>– Start report on one device only.</p>
<p>Unit price too large</p>	<p>– Appears during sales.</p>	<p>– Check the settings for sales limits in "Configuration" / "Device settings" / "Sales limits".</p>
<p>Preset tare error</p>	<p>– Appears during sales. When entering a known tare, the tare value may not exceed the lower division range on a two-interval scale.</p>	<p>– Enter tare in lower division range only.</p>
<p>Cash drawer X is not connected</p>	<p>– Appears in cash register mode.</p>	<p>– Check the set values of the operator used in "Data maintenance" / "Operator data". – Check the SC II connection cable for the cash drawer.</p>



Text message	Cause	Remedy
Cashier has not determined a Cash reg. (POS) act.!	<ul style="list-style-type: none"> <li>– Appears for cashier reports.</li> </ul>	<ul style="list-style-type: none"> <li>– In "Configuration" the setting, "Compulsory cash reg. POS act." must be set in the "Cash reg." menu. If a cashier does not perform the "Cash reg. (POS) act." before printing out the cashier reports, the report will not be printed out.</li> <li>Before the reports can be printed, the "Cash reg. (POS) act." must be recorded by each cashier or the reports must be evaluated with the following range setting:                      "From cashier 001"                      "To cashier 999"                      "Only cashier total yes"</li> </ul>
No extra text under this number!	<ul style="list-style-type: none"> <li>– Appears during sales when calling a general text with the "Call gen. text" key.</li> </ul>	<ul style="list-style-type: none"> <li>– Check the entered text number.</li> <li>– In the "Data maintenance" / "Texts" / "Gen. texts" menu, check the entry for the applied text number.</li> </ul>
No overwriting	<ul style="list-style-type: none"> <li>– Appears during sales.</li> <li>– PLU is locked in PLU maintenance for price overwriting.</li> </ul>	<ul style="list-style-type: none"> <li>– Switch on price overwrite</li> </ul>
No ticket data existing	<ul style="list-style-type: none"> <li>– Appears during sales when entering the ticket no. with the "Enter ticket no." key.</li> </ul>	<ul style="list-style-type: none"> <li>– Check that entered ticket no. is correct. Re-enter.</li> <li>– Ticket copy is no longer available in the ticket/journal memory. Check size of ticket/journal memory in "Commissioning". Check the settings for the ticket/journal memory in "Configuration".</li> </ul>

Text message	Cause	Remedy
No customer number	<ul style="list-style-type: none"> <li>– Appears during sales during overlapping service with customer/operator link.</li> </ul>	<ul style="list-style-type: none"> <li>– The operator used does not have a link to a customer no.</li> </ul>
No module license exists!	<ul style="list-style-type: none"> <li>– Appears if an attempt is made to use an unlicensed function.</li> </ul>	<ul style="list-style-type: none"> <li>– Apply for license no.</li> </ul>
No items	<ul style="list-style-type: none"> <li>– Appears during sales. Operator has not sold anything up to totals print-out.</li> </ul>	<ul style="list-style-type: none"> <li>– Register PLU.</li> </ul>
No registration	<ul style="list-style-type: none"> <li>– Appears during sales. General error, registration is denied. Example: Unit price 0.00 EUR Selling price 0.00 EUR</li> </ul>	<ul style="list-style-type: none"> <li>– Enter unit price.</li> </ul>
No additional data available, scale error	<ul style="list-style-type: none"> <li>– During an ongoing evaluation, an SC II was switched off. Bus faults</li> </ul>	<ul style="list-style-type: none"> <li>– Check bus cable (from SC II to SC II).</li> </ul>
No total markup/discount	<ul style="list-style-type: none"> <li>– Appears in cash register mode.</li> <li>– When entering product markup/discount.</li> </ul>	<ul style="list-style-type: none"> <li>– In the Tendered menu, only the totals-markup/deductions key is accepted.</li> </ul>
Customer not created	<ul style="list-style-type: none"> <li>– Appears when creating delivery notes, orders. After input of customer no. with the "Delivery note" or "Order" key.</li> </ul>	<ul style="list-style-type: none"> <li>– Check customer data in "Data maintenance" / "Customer data".</li> </ul>
Customer no. is already used by Operator: XXX	<ul style="list-style-type: none"> <li>– Appears during sales during overlapping service with customer/operator link. The used customer no. is occupied by another operator.</li> </ul>	<ul style="list-style-type: none"> <li>– Undo customer/operator link. See Operation chapter.</li> </ul>
No multiplication	<ul style="list-style-type: none"> <li>– Appears in the quick service mode.</li> </ul>	<ul style="list-style-type: none"> <li>– Multiplication is only supported with piece PLUs.</li> </ul>

Text message	Cause	Remedy
Max. value overflow	<ul style="list-style-type: none"> <li>– Appears during sales.</li> </ul>	<ul style="list-style-type: none"> <li>– Check the settings for totals in sales limits in "Configuration" / "Device settings" / "Sales limits".</li> </ul>
End of month is still active!	<ul style="list-style-type: none"> <li>– Appears when an ongoing monthly evaluation in connection with time recording is interrupted by having switched off the scales.</li> </ul>	<ul style="list-style-type: none"> <li>– The monthly evaluation can be reapproved in the "Additional functions" / "Time recording" / "End of month" menu.</li> </ul>
End of paper! Automatic paper ejection and feed	<ul style="list-style-type: none"> <li>– Appears for receipt printers if the ticket paper runs out during a printout.</li> </ul>	<ul style="list-style-type: none"> <li>– The paper is ejected automatically. Insert new paper. The paper is pulled in automatically. Printing is repeated.</li> <li>– Insert paper correctly.</li> </ul>
Automatic paper ejection and feed End of paper! Continue with label printing, ticket printing or label printing on ticket paper?	<ul style="list-style-type: none"> <li>– Appears for label printers if the labels run out during a printout.</li> </ul>	<ul style="list-style-type: none"> <li>– Insert new label or ticket roll. Depending on the paper used, select with the cursor:                             <ul style="list-style-type: none"> <li>– Label printing, for labels</li> <li>– Ticket printing, for ticket paper</li> <li>– Label printing on ticket paper, for endless adhesive paper.</li> </ul> </li> <li>– Insert paper correctly.</li> </ul>
PLU not found	<ul style="list-style-type: none"> <li>– Appears during sales.</li> </ul>	<ul style="list-style-type: none"> <li>– Check the selected PLU in PLU maintenance.</li> <li>– Enter the correct PLU no.</li> <li>– Check menu items "PLU access via department" and "EAN/UPC access via dept.".</li> </ul> <p>Note department organization. Select <b>5 3 5</b></p>

Text message	Cause	Remedy
Price invalid	<ul style="list-style-type: none"> <li>– Appears during sale of manual products.</li> </ul>	<ul style="list-style-type: none"> <li>– Check menu item "Rounding not weighed". If rounding is activated, the price used must correspond to the rounding. Select <b>5 3 6 3</b></li> </ul>
Seasonal PLU locked	<ul style="list-style-type: none"> <li>– This appears when a PLU is opened.</li> </ul>	<ul style="list-style-type: none"> <li>– In the menu "PLU maintenance" / "Other", switch off the menu item "PLU locked". Select <b>1 1 2 / Dep.no. / PLU no. / 4</b></li> </ul>
Please close the cash drawer	<ul style="list-style-type: none"> <li>– Appears in "Amount tend./Change op.", if the next customer is to be served with the drawer open using the "ESC" key, and compulsory drawer closure is set.</li> </ul>	<ul style="list-style-type: none"> <li>– Check the "Configuration" / "Cash reg." / "Registr. when cash reg. is open" menu. Select <b>5 3 4</b></li> </ul>
Total overflow	<ul style="list-style-type: none"> <li>– Appears for cash register or cashier report. The values in the report exceed 9 999 999. No total report is subsequently printed.</li> </ul>	<ul style="list-style-type: none"> <li>– Print out and delete the cash register and cashier reports.</li> </ul>
Tare assigned	<ul style="list-style-type: none"> <li>– Appears during sales.</li> </ul>	<ul style="list-style-type: none"> <li>– Manual tare cannot be overwritten with a tare fixed value.</li> </ul>
Taring is not OK	<ul style="list-style-type: none"> <li>– Appears during sales.</li> </ul>	<ul style="list-style-type: none"> <li>– PLU tare, the tare fixed value and manual tare cannot be combined with each other.</li> </ul>
Key is assigned by operator with open ticket.	<ul style="list-style-type: none"> <li>– Appears during sales during operator log on/log off.</li> </ul>	<ul style="list-style-type: none"> <li>– The displayed operator must end his ticket with "Total" and then log off.</li> </ul>
Key not allowed!	<ul style="list-style-type: none"> <li>– Appears during sales. The function of the actuated key cannot be executed at this point.</li> </ul>	<ul style="list-style-type: none"> <li>– Check that operating procedure is correct.</li> <li>– Check that keyboard programming is correct.</li> </ul>

Text message	Cause	Remedy
Invalid ticket type!	<ul style="list-style-type: none"> <li>– Appears for price group mode 1, 2 or 3.</li> </ul>	<ul style="list-style-type: none"> <li>– A ticket begun with one of the above price groups cannot be changed to another price group during the sale. Conclude ticket with "Total" and begin new ticket with the desired price group.</li> </ul>
Unbuffered heap is too highly fragmented	<ul style="list-style-type: none"> <li>– Appears in conjunction with multi-line text editors. The text editor cannot be created in the unbuffered RAM area.</li> </ul>	<ul style="list-style-type: none"> <li>– SC II off/on. The unbuffered area is deleted and redefined.</li> </ul>
Different ticket type!	<ul style="list-style-type: none"> <li>– Appears in               <ul style="list-style-type: none"> <li>– Inventory mode</li> <li>– Returns mode</li> <li>– Wastage weighing mode</li> </ul> </li> </ul>	<ul style="list-style-type: none"> <li>– An operator has started working with one of the above-specified operating modes and another operator wishes to work in normal selling mode. It is only possible to continue working on the device in another operating mode if the first operator ends his operating mode with the "Total" key or interrupts his operating mode. Two different operating modes cannot be used simultaneously.</li> </ul>
Different transaction type!	<ul style="list-style-type: none"> <li>– Appears if creating "Delivery note", "Purchase order", "Inventory", "Wastage weighing" and "Returns".</li> </ul>	<ul style="list-style-type: none"> <li>– If a ticket has been started in a specific operating mode, this operating mode cannot be changed within this ticket. The ticket currently in process has to be closed via the "Totals key".</li> </ul>
Overload	<ul style="list-style-type: none"> <li>– Appears during sales. During the registration attempt the scales were in an overload range.</li> </ul>	<ul style="list-style-type: none"> <li>– Place light weight on scales that is within the weighing range of the SC II.</li> </ul>

Text message	Cause	Remedy
Log on operator!	<ul style="list-style-type: none"> <li>– Appears during sales when working with compulsory log on/log off. "Configuration" / "Cash reg."</li> </ul>	<ul style="list-style-type: none"> <li>– No operator is logged on to the selected operator key.</li> </ul>
Operator occupied	<ul style="list-style-type: none"> <li>– Appears during sales. The active operator performs actions on another SC II, e.g.: scroll function, ticket printout.</li> </ul>	<ul style="list-style-type: none"> <li>– When the function is ended, the operator is released again.</li> </ul>
Operator is not permitted as cashier on this device	<ul style="list-style-type: none"> <li>– Appears in cash register mode or with "Other functions" / "Cash register (POS)".</li> </ul>	<ul style="list-style-type: none"> <li>– Check the set values of the operator used in "Data maintenance" / "Operator data".</li> <li>– Check keyboard programming in "Configuration" / "Define keys" and in "Data maintenance" / "Operator data" / "Operator key".</li> </ul>
Operator invalid	<ul style="list-style-type: none"> <li>– Appears during sales. SC II is set in "Configuration" / "Device settings" such that multiple operation is not permitted.</li> </ul>	<ul style="list-style-type: none"> <li>– If an operator has started a ticket at a device, the next operator cannot begin until the first operator has pressed "Total".</li> </ul>
Selling price too high	<ul style="list-style-type: none"> <li>– Appears during sales.</li> </ul>	<ul style="list-style-type: none"> <li>– Check the settings for sales limits in "Configuration" / "Device settings".</li> </ul>
Load scale.	<ul style="list-style-type: none"> <li>– After being switched on the scales are in an underload range.</li> </ul>	<ul style="list-style-type: none"> <li>– possibly, place meat cavity on scales.</li> <li>– Check load plate and housing contact.</li> </ul>
Unload scale	<ul style="list-style-type: none"> <li>– When switched on the scales are in overload range.</li> <li>– Appears when self-service mode is activated.</li> </ul>	<ul style="list-style-type: none"> <li>– Remove weight from load plate.</li> <li>– Check load plate for clearance.</li> </ul>
Scale unstable	<ul style="list-style-type: none"> <li>– Scale is located in an erratic location when switched on (draft, vibrations).</li> </ul>	<ul style="list-style-type: none"> <li>– Relocation</li> <li>– Sensitivity adjustment option (market scale program) "Configuration" / "Cash reg."</li> </ul>

Text message	Cause	Remedy
Not enough memory, unbuffered heap	– Appears in conjunction with multi-line text editors. The text editor cannot be created in the unbuffered RAM area.	– SC II off/on. The unbuffered area is deleted and redefined.

## 8 Maintenance

### 8.1 Cleaning

Cleaning instructions must be observed during installation, operation and maintenance.

#### 8.1.1 Cleaning device

	<b>⚠ DANGER</b>
	<p><b>Water getting into device!</b>  <b>Danger of death from electric shock.</b></p> <ul style="list-style-type: none"> <li>– make sure that no water runs into the device when cleaning.</li> <li>– Do not wash device off or spray-wash.</li> </ul>
	<b>NOTICE</b>
	<p><b>Incorrect cleaning agents!</b>  <b>Damage of device surfaces.</b></p> <ul style="list-style-type: none"> <li>– Do not use spirit, acetone or aggressive cleaning or scouring agents.</li> </ul>



Switch device off and disconnect the plug.

Use warm water with dish-washing detergent (food safe) for cleaning. Use a soft, non-fraying cloth, moistened lightly.

#### 8.1.2 Cleaning the printer

##### Tear-off edge

	<b>⚠ CAUTION</b>
	<p><b>Sharp-edged tear-off edge!</b>  <b>Cut-injuries at finger.</b></p> <ul style="list-style-type: none"> <li>– Do not touch tear-off edge.</li> </ul>



## ① Tear-off edge

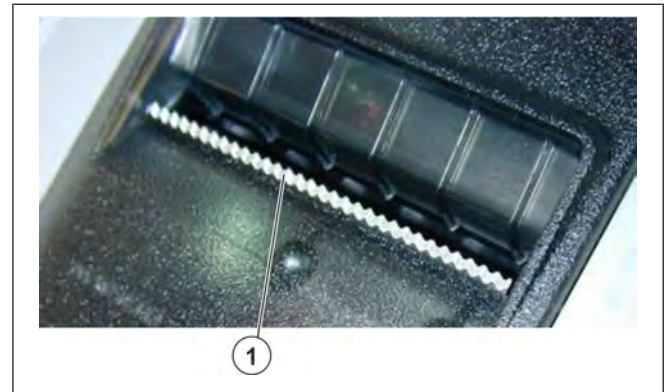

Illustration 73: Tear-off edge

## Cleaning thermal strip

Label printer or linerless printer.

The thermal strip must be cleaned on a regular basis and as soon as you notice that the printing quality has decreased.

### NOTICE

#### Coated thermal strip!

- The thermal strip is coated with a glass passivation layer and must not be touched or cleaned with hard objects.
- Use Bizerba cleaning products to clean the thermal strip.

- ⇒ Open the side cover of the scale.
- ⇒ Open the printer lid by pulling it upwards.
- ⇒ Open the print head.
- ⇒ Clean the thermal strip ① using the Bizerba thermal print head cleaning pen or dip a cleaning pad in Bizerba cleaning solvent.
- ⇒ Afterwards, dry off using a dry cleaning pad.

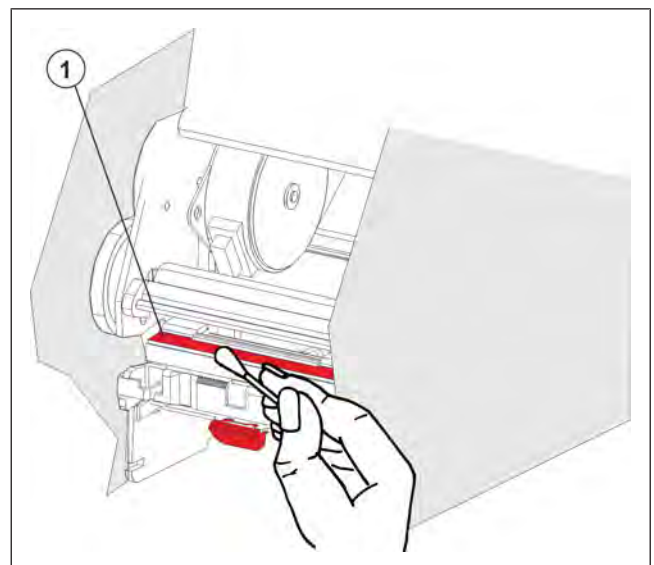

Illustration 74: Print head

## Clean label printer

Inspect label printer weekly and clean it from glue residue deposits on deflection roller, take-up pin and paper deflector.

**Clean the deflection roller and take-up pin.**

- ⇒ Open the printer lid and print head.
- ⇒ Remove the label roll.
- ⇒ Remove glue residues from parts ①.

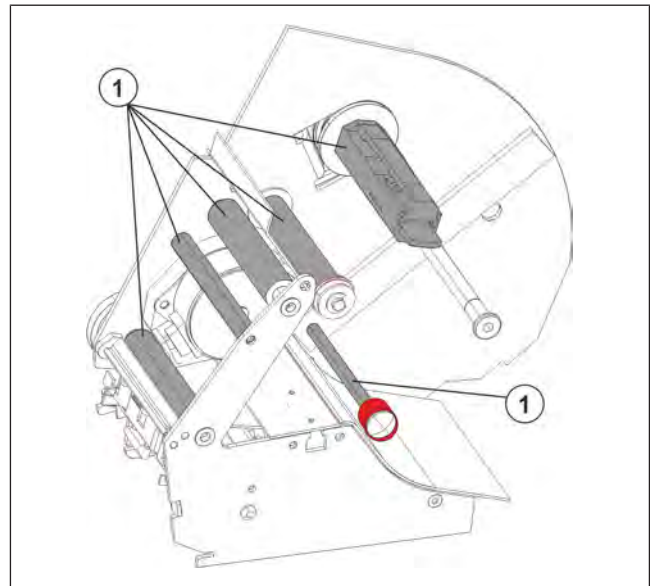

Illustration 75: deflection pin, take-up pin

**Clean paper deflector**

- ⇒ Pull the paper deflector ② out sideways.
- ⇒ Clean the paper deflector using the Bizerba "LR label remover". The "LR-label remover" may **not** be used to clean thermal strips.
- ⇒ Push the paper deflector ② in sideways.

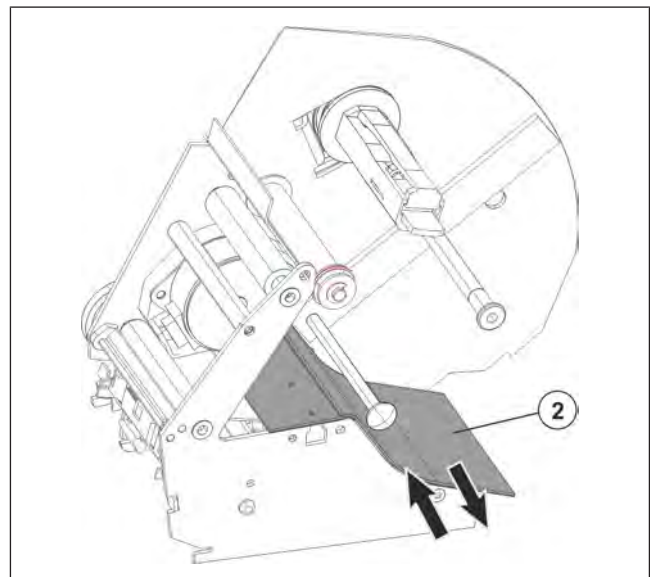

Illustration 76: Paper deflector

**8.1.3 Cleaning products for printer****Ordering information**

The cleaning products can be obtained from Bizerba Service or Bizerba technical consultants.

**Glue residue removal agent**

Aerosol can, 200ml

Order no.: 9594 3000000



Illustration 77: Cleaner for residues of glue from labels

<b>NOTICE</b>
<p><b>Thermal strip coating and rubber rollers!</b></p> <p><b>Damage to the coating</b></p> <ul style="list-style-type: none"> <li>– Do not use label remover for cleaning thermal strip and rubber rollers!</li> </ul>

**Cleaner for thermal strip**

Cleaning pen 12ml

Order no.: 5077 7050000



Illustration 78: Cleaner for thermal strip

or

Aerosol can, 200ml

Order no.: 9400 8900133



Illustration 79: Aerosol can

### Thermal strip cleaning set

consisting of:

5 cleaning buds made of wood with leather coating

1 pcs. IPA cleaning solvent 12 ml

Order no.: 9400 8919 000



Illustration 80: Thermal strip cleaning set

- ⇒ Moisten the tip of the cleaning bud with a few drops of the cleaning solvent.
- ⇒ Clean the thermal strip immediately with cleaning bud.



Illustration 81: Application

## 8.2 Maintenance

The load plate must be removed every 4 weeks and loose dirt removed with a brush or vacuum cleaner.

Replace the load plate and check the zero point of the scale. Switch the scale off and on if necessary.

### 8.2.1 Testing the weight display

Place reference weight of 2x3 kg on the scale and read off the display at 3 and 6kg.

This test must be repeated at regular intervals.

## 8.2.2 Note on storing thermal paper

Store unprinted thermal paper without direct light exposure to light (original packaging) in closed box or similar, if possible. If kept at temperatures up to a maximum of 60° Celsius and at a relative air humidity of max. 65%, the paper will retain its printability for up to 5 years.

Printed thermal paper will be readable for up to 10 years if not exposed to direct sunlight and if kept at temperatures up to a maximum of 30° Celsius and at a relative air humidity of max. 65%.

## 8.2.3 Ticket, label and linerless rollers

To avoid any defects on the device, only ticket, label or Linerless rolls that have been checked and approved by Bizerba are to be used. These ticket and label rollers are identified with a corresponding number.

We are not liable for damage/faults that are produced from using ticket and label rolls that have not been checked and approved by Bizerba.

Please order ticket, label and Linerless rolls exclusively at your respective Bizerba sales office or directly at:

Bizerba Labels & Consumables GmbH

Harpener Hellweg 31

44805 Bochum 1

Germany

Tel: +49 234 / 9557-0

FAX: +49 234 / 5070247

## 9 Technical data

### 9.1 Dimensions

#### Scale SC II 800

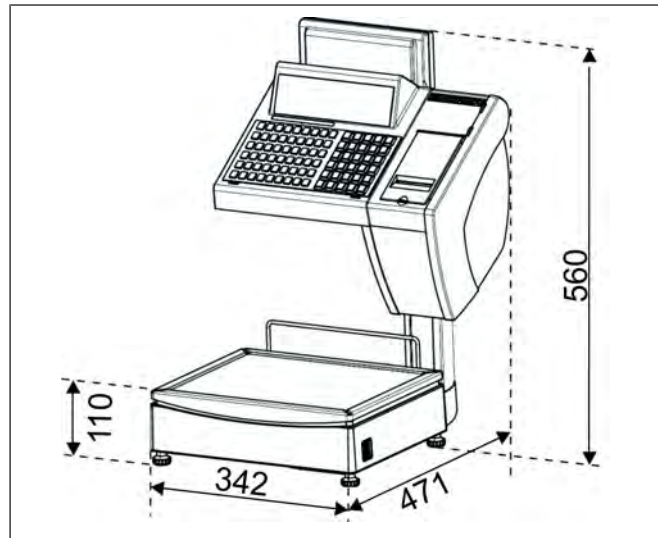

Illustration 82: SC II 800

#### Scale SC II 100

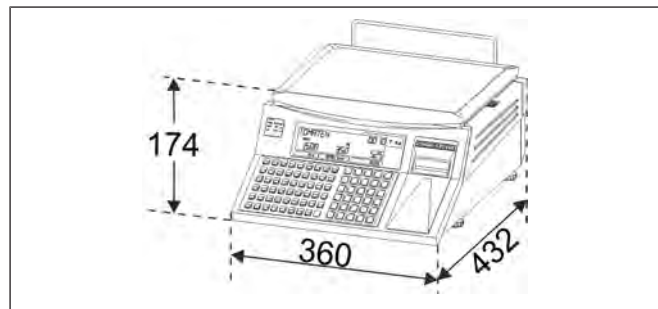

Illustration 83: SC II 100

#### Scale SC II 200

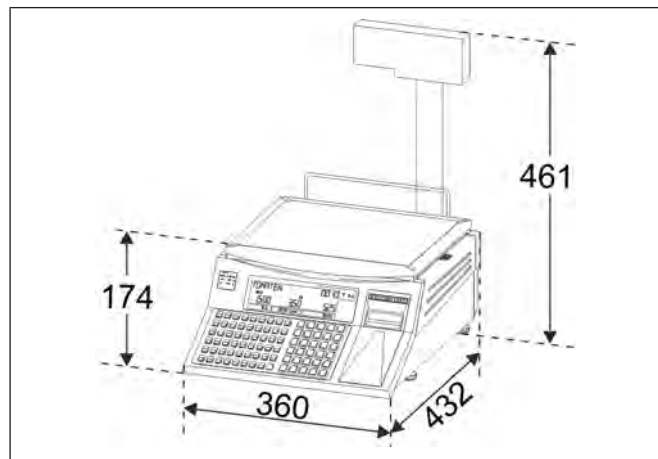

Illustration 84: SC II 200

### 9.2 Power supply

The electrical power supply must comply with the national requirements and tolerances.

#### Mains supply

Single-phase A.C. voltage, see data on type plate.

Permissible mains voltage tolerance (steady-state) normal:

120V: + 6% to - 10% of nominal value

230V: +10% to -10% of nominal value

Mains frequency :	50Hz
Permissible tolerance of mains frequency:	+2 to -2%
Admissible distortion factor of mains voltage:	≤ 5%
Leakage current protective conductor max.:	3.5 mA

Voltage min. = 11V, max. = 14V

Average current drain 400mA

The power source (external battery) must meet the requirements of the power limit in accordance with UL 60950 und IEC 60950-1: 2001, para. 2.5 (limited power source).

### 9.3 Ambient conditions

Strictly adhere to the following requirements when applying electronic retail scales weighing and EDP systems, recording units and similar devices, device combinations and spare parts. For other manufacturers' equipment included in our scope of supply, the respective manufacturer's regulations take preference if they deviate from our conditions.

#### Limit values

Device family	Protection class as per IP	Temperature °C Celsius (degF Fahrenheit)				Relative humidity %			
		Operation		Storage		Operation		Storage	
		min.	max.	min.	max.	min.	max.	min.	max. <sup>1</sup>
EDP systems:	20	+15 (+60)	+30 (+87)	-10 (+14)	+43 (+109)	8	80	20	80
Retail scales	20	-10 (+14)	+40 (+104)	-20 (-4)	+60 (+140)		90		90
Label rolls		-10 (+14)	+40 (+104)	+15 (+60)	+35 (+94)		80	30	80
Ticket rolls		-10 (+14)	+40 (+104)		+30 (+87)		60		60 <sup>2</sup>
External devices	The limit values of the respective manufacturers apply								

<sup>1</sup> Moisture condensation of equipment not permissible

<sup>2</sup> Unprinted and packaged thermal paper

## Subject index

<b>A</b>		<b>D</b>	
Ambient conditions	95	Data of origin	57
Article type "By-count"	71	Change	58
Assisted sale with labels	56	Manually	57
<b>B</b>		Suggestion	59
Bakery device		Date / time	75
Operation with weight PLU	42	Deleting characters	41
SCII 100 K/B	41	Demo license	17
Switch-on	42	Device types	10
By-count	71	Display	25
Fixed weight	71	Symbols	25
Weighed	69	Display controls	
<b>C</b>		Brightness	20
Cable connections	22	Contrast	21
Cancel during scrolling	50	Disposal	17
Canceling function	41	Document description	7
Cancellation	50	<b>E</b>	
Cancel by paging	51	End of label	34
Immediate cancellation	50	End of ticket paper	35
Care	88	Environmental protection	17
Cash payment	61	<b>F</b>	
Pay-in/pay-out mode	61	Fixed tare key	54
Cash register functions	61	Fixed volume	56
Cash register terminal SCII 100 K/B	41	<b>G</b>	
Clean label printer	89	Graduated price	62
Cleaning	88	Amount graduation	64
Cleaning products	90	n*amount graduation	63
Cleaning the printer	88	n*quantity grad.	63
Constant	49	Percent graduation	64
Customer ticket can be switched off	12	<b>H</b>	
		Humidity	95
		<b>I</b>	
		Input of number of bags obligatory	67
		Insert ticket roll	36
		Install label roll	35
		Instant cancel	50
		Interference suppression	15



**K**

Kennzeichnungsschild	10
Key functions	28
Keyboard	26
Key functions	28
Membrane keyboard	27
Tactile keyboard	28

**L**

Label printer	34
Legend	7
Leveling of scale	21
Logbook update	12

**M**

Main switch	25
Mains connection	18
Mains connection AC	15
Mains supply	22
Maintenance	92
Mandatory input for By-count	75
Manual fixed weight	70
Manual input	48
Manual input price per piece	48
Manual tare	54
Manual weighed	68
Membrane keyboard	27
Minus amount	48
Mixed special price	65
Multiplication	
Manual input price per piece	48
Manual weight input	46
Minus amount	49
Partial number of pieces	47
PLU price per piece	46

**N**

n*amount graduation	63
n*quantity grad.	63
N/C	62
Normal price	62
Normal ticket	55

**O**

Obligatory input for piece price	66
Operating conditions	14
Operating safety	18

**P**

Paper feed	37
Label printer SC II 100/200, label paper	38
Label printer SC II 100/200, ticket paper	38
Label printer SC II 800, label paper	37
Label printer SC II 800, ticket paper	37
Pay-in/pay-out mode with cash payment	61
Place of installation	21
PLU	43
Autom. prefix	44
Call-up	43
PLU tare	54
Registration	45
Unit price input after PLU call-up	45
Power supply	15, 94
Price = 0	46
Price type	
Amount graduation	64
Graduated price	62
Mixed special price	65
n*amount graduation	63
n*quantity grad.	63
N/C	62
Normal price	62
Percent graduation	64
Price types	62
print head	
Open/close	33
Printer	30
Label printer	34
Printer lid and side cover for BC II 800	32
Printer lid BC II 100/200	30
Side cover BC II 100/200	31
Thermal print head	33
Ticket printouts	35
Product group sale	
By PLU	49
Protection	95

**R**

Rechargeable battery	23
Rounding rule	53

<b>S</b>		<b>U</b>	
Safety instructions	18	Unit price	
SC II 100 K/B, operation	41	Input: Price/100g	48
Scroll function	50	Input: Price/kg	47
Self-service mode	60	Unit price / selling price = 0	46
Set display	20	Unit price back calculation	
Set paper width	39	In case of fixed price change	71
Setting the display	20		
Side cover	31	<b>V</b>	
Software ID	12	Verification	12
Stack tare	52	Verification information	12
Standards and directives	13		
Start-up	20	<b>W</b>	
Storage		Warnings	8
Device	20, 95	Warranty	16
Subtotal		Weight fixed price article	
Display	51	By-count fixed weight	71
Supply voltage	18, 22	By-count weighed	69
Switch off	41	Manual fixed weight	70
Switch on	40	Manual weighed	68
Switch-on	42	Weight-fixed-price article	68
Symbols	7	Wireless LAN device network	16
<b>T</b>		<b>Z</b>	
Tactile keyboard	28	Zero setting	41
Tare	52		
Delete	54		
Manual tare	54		
PLU tare	54		
Stack tare	52		
Tare balancing	52		
Via fixed tare key T1-Tx	54		
Tare function			
Known tare	53		
Unknown tare	52		
Temperature	95		
Thermal paper storage	93		
Thermal strip			
Clean	89		
Close	34		
Ticket printouts	35		
Total	52		
Transport	20		

## **10     Annexe**



## Declaration of conformity

valid until 4/19/2016

We herewith declare that the materials used for the following non-automatic scale

<b>Definition:</b>	retail scale / system scale
<b>Typ:</b>	Type... (100, 200, 400, 500, 800)
<b>No. of EC type approval certificate:</b>	D10-09-010
<b>No. of notified body for EC type approval certificate:</b>	0102 (PTB)

complies with the type described in the type approval certificate and the current requirements of the following EC directives:

Directive on non-automatic weighing instruments	2009/23/EG
EMC directive on electromagnetic compatibility	2004/108/EG
Directive on electrical equipment designed for use within certain voltage limits	2006/95/EG

Applied national technical standards and specifications:

Metrology:	DIN EN 45501: 1992 (OIML R76-1, 2006)
EMC:	DIN EN 61000-6-1/ 2007-10; DIN EN 55022/2011-12 DIN EN 61000-3-2/ 2010-03; DIN EN 61000-3-3/ 2014-03
Safety:	DIN EN 60950-1
WLAN module (optional):	See data in declaration of conformity of manufacturer.

**The Declaration of Conformity only applies with regard to the EC Scales Guideline in conjunction with a conformity certification from an appointed body.**

This sentence is omitted when the conformity evaluation has been carried out by Bizerba.

The declaration of type conformity is based on contractual documents (Bizerba order documents). Any modification made to the above device type without the prior permission of Bizerba or by Bizerba staff will render this declaration invalid.

Date: 05/20/2015

Signature of manufacturer:

By proxy

Dr. Christian Tölg

Director Global Retail Systems Technology

Bizerba GmbH & Co. KG

Title of signatory:

Bizerba GmbH & Co. KG  
Wilhelm-Kraut-Straße 65  
72336 Balingen, Germany

# BIZERBA



## EU declaration of conformity

Valid from 4/20/2016

We herewith declare that the device indicated hereafter conforms to the specified applicable requirements and the requirements set out in EU legislation.

Device type:	Non-automatic, elektromechanical scale
Model:	SC II 100 / SC II 200 / SC II 400 / SC II 500 / SC II 800

Approval for this device type:

Type:	SC II...
Number of EC type-approval:	D10-09-10
Identification no. of notified body for EU type-approval:	0102 Physikalisch-Technische Bundesanstalt (PTB)

EU legislation:

Non-automatic weighing instruments:	2014/31/EU; Official Journal of the EU issued on 29.03.2014 L96 pp. 107-148
EMC:	2014/30/EU; Official Journal of the EU issued on 29.03.2014 L96 pp. 79-106
Low voltage:	2014/35/EU; Official Journal of the EU issued on 29.03.2014 L96 pp. 357-374

Applied national technical standards and specifications:

Metrology:	EN 45501:2015; OIML R76-1, 2006
EMC:	EN 61000-6-1:2007; EN 55022:2010 EN 61000-3-2:2006 + A1:2009 + A2:2009; EN 61000-3-3:2013
Electrical safety:	EN 60950-1
With WLAN module (optional):	2014/53/EU; Official Journal of the EU issued on 04/16/2014 L153 pp. 62-106 EN 62311:2008 EN 301 489-17 V2.2.1:2012; EN 301 489-1 V1.8.1:2008 EN 300 328 V1.8.1:2012; EN 301 893 V1.7.1:2012

The declaration of type conformity is based on contractual documents (Bizerba order documents). Any modification made to the above device type without the prior permission of Bizerba or by Bizerba staff will render this declaration invalid.

Date: 02/17/2016

Signature of manufacturer:

By proxy

Sebastian Richter

Title of signatory:

Director Retail Systems Technology

Bizerba GmbH & Co. KG

## 10.1 WLAN\_BWLC2

		Product Service	
<h1>EXPERTISE</h1>			
Expert Opinion of the Notified Body based on the Conformity Assessment according to Annex IV of the R&TTE Directive 1999/5/EC			
<b>Eurofins Product Service GmbH</b>			
EU Identification Number <b>0681</b>			
recognized by			
 Bundesnetzagentur			
BNetzA-bS-02/51-53			
Registration Number:	<b>G0M-1410-4202-C-V01</b>		
Certification Holder:	<b>modas GmbH</b> <b>Belziger Str. 69-71, 10823 Berlin</b> <b>GERMANY</b>		
Model Name:	<b>BWLC2</b>		
Brand Name:			
Product Description:	<b>WLAN to Ethernet Client Adapter</b>		
Applied specifications / standards according to corresponding R&TTE article:			
3.1a Safety/Health:	<b>EN 62311:2008</b> <b>Electrical Safety not assessed</b>		
3.1b EMC:	<b>EN 301 489-17 V2.2.1:2012-09</b> <b>EN 301 489-1 V1.8.1:2008-04</b>		
3.2 Radio:	<b>EN 300 328 V1.8.1:2012-06</b> <b>EN 301 893 V1.7.1:2012-06</b>		
This EXPERTISE is issued in accordance with the Directive 1999/5/EC of the European Parliament and the Council on radio equipment and telecommunications terminal equipment and the mutual recognition of their conformity dated 9th March 1999 and is only valid in conjunction with the following annex: - 1 - (3 pages)			
Marking Example according to Article 12 of the R&TTE Directive:			
		<b>Reichenwalde, 2015-04-15</b> Ort, Ausstellungsdatum Place, Date of Issue	 Unterzeichnet von/Signed by Adelheid Kutzker Benannte Stelle/Notified Body
Eurofins Product Service GmbH Storkower Strasse 38c, D-15526 Reichenwalde b. Berlin, Germany, Phone +49-33631-888 000 Fax +49-33631-888 650			

Illustration 85: WLAN BWLC2



**Product Service**

ACCREDITED TEST HOUSE    RECOGNIZED CERTIFICATION BODY

## Statement of SDoC

This states that the following designated product

**WLAN to Ethernet Client Adapter**

**Model No.:        BWLC2**

.....  
(Product identification)

complies with the maximum emission levels based on the following rules:

**contains: IC: 4104A-AR5BHB116  
ICES-003, Issue 5, August 2012**

.....  
(Identification of regulations / standards)

This statement is issued for

**modas GmbH  
Belziger Str. 69-71  
10823 Berlin, GERMANY**

.....  
(Name / Address)

Important Notes:

This Standard (ICES-003) refers to the following publication and where such reference is made, it shall be to the edition listed below.  
Canadian Standards Association Standard CAN/CSA-CEI/IEC CISPR 22:02, "Limits and Methods of Measurement of Radio Disturbance Characteristics of Information Technology Equipment."

The manufacturer/importer has to take the necessary steps to insure that the equipment complies with the appropriate technical standards. Submittal of a sample unit or representative data to the IC Canada demonstrating compliance is not required unless specifically requested by the IC Canada.

6.1 A record of the measurements and results, showing the date that the measurements were completed, shall be retained by the manufacturer or importer for a period of at least five years from the date shown in the record and made available for examination on the request of the Minister.

6.2 A written notice indicating compliance must accompany each unit of digital apparatus to the end user. The notice shall be in the form of a label that is affixed to the apparatus. Where because of insufficient space or other constraints it is not feasible to affix a label to the apparatus, the notice may be in the form of a statement included in the user's manual. A suggested text for the notice, in English and in French, is provided below.

Suggested text for the notice indicating compliance with this Standard:  
This Class [\*] digital apparatus complies with Canadian ICES-003.  
Cet appareil numérique de la classe [\*] est conforme à la norme NMB-003 du Canada.

\* Insert either "A" or "B" but not both to identify the applicable Class of ITE.

The statement is valid only in accordance with the test report No. G0M-1410-4202-EF01-V03 and when the product is manufactured in accordance with the tested sample.

EU Notified Body - LVD EMC R&TTE \* NCB - IECCE CB Scheme \* GS Body \* eurofins - Bauart geprüft \* TSC E-Mark  
TCB - FCC USA \* FCB - Industry Canada \* BQTF - Bluetooth® \* International Type Approval Service



**G0M-1410-4202**

This is the result of tests carried out on those samples of the product referred to above which were submitted for testing, in accordance with the specification for the respective standards.  
Eurofins Product Service GmbH - Accredited Test House -  
Recognized Certification Body



Eurofins Product Service GmbH  
Storkower Strasse 38c, 15526 Reichenwalde bei Berlin, Germany, Phone +49-33631-888 000 Fax +49-33631-888 650

Illustration 86: WLAN BWLC2

61429850113 en-US

103 / 107

		<b>Product Service</b>
ACCREDITED TEST HOUSE    RECOGNIZED CERTIFICATION BODY		
<b>STATEMENT OF DECLARATION OF CONFORMITY</b>		
This states that the following designated product		
<b>WLAN to Ethernet Client Adapter contains FCC ID: PPD-AR5BHB116</b>		
<b>Model No.:      BWLC2</b>		
..... (Product identification)		
complies with the maximum emission levels based on the following rules:		
<b>47 CFR Part 15 Subpart B</b>		
..... (Identification of regulations / standards)		
This statement is issued for		
<b>modas GmbH Belziger Str. 69-71 10823 Berlin, GERMANY</b>		
..... (Name / Address)		
The statement is valid only in accordance with the test report No. G0M-1410-4202-EF01-V03 and when the product is manufactured in accordance with the tested sample.		
<p><small>Important Notes: The following parties are responsible for the compliance of radio frequency equipment in the case of equipment subject to authorization under the Declaration of Conformity procedure (DoC): (1) The manufacturer or, if the equipment is assembled from individual component parts and the resulting system is subject to authorization under a DoC, the assembler. (2) If the equipment, by itself, is subject to a DoC and that equipment is imported, the importer. (3) Retailers or original equipment manufacturers may enter into an agreement with the responsible party designated in (1) or (2) of this section to assume the responsibilities to ensure compliance of equipment and become the new responsible party. (4) If the radio frequency equipment is modified by any party not working under the authority of the responsible party, the party performing the modifications, if located within the U.S., or the importer, if the equipment is imported subsequent to the modifications, becomes the new responsible party.</small></p> <p><small>A DoC is a procedure where the responsible party makes measurements or takes other necessary steps to ensure that the equipment complies with the appropriate technical standards. Submittal of a sample unit or representative data to the Commission demonstrating compliance is not required unless specifically requested pursuant to §2.1076. The DoC attaches to all items subsequently marketed by the responsible party which are identical, as defined in §2.906, to the sample tested and found acceptable by the responsible party. (a) The DoC signifies that the responsible party, as defined in §2.909, has determined that the equipment has been shown to comply with the applicable technical standards if no unauthorized change is made in the equipment and if the equipment is properly maintained and operated. Compliance with these standards shall not be construed to be a finding by the responsible party with respect to matters not encompassed by the Commission's rules. (b) A DoC by the responsible party is effective until a termination date is otherwise established by the Commission. (c) No person shall, in any advertising matter, brochure, etc., use or make reference to a DoC in a deceptive or misleading manner or convey the impression that such a DoC reflects more than a determination by the responsible party that the device or product has been shown to be capable of complying with the applicable technical standards of the Commission's rules.</small></p> <p><small>§ 2.1072 Limitation on Declaration of Conformity. (a) The Declaration of Conformity signifies that the responsible party, as defined in §2.909, has determined that the equipment has been shown to comply</small></p>		
EÜ Notified Body - LVD EMC R&TTE = NCB - IECCE CB Scheme = GS Body = eurofins = Bauart geprüft = TSC E-Mark TCB - FCC USA = FCB - Industry Canada = BQTF - Bluetooth® = International Type Approval Service		
	<p>This is the result of tests carried out on those samples of the product referred to above which were submitted for testing, in accordance with the specification for the respective standards. Eurofins Product Service GmbH – Accredited Test House – Recognized Certification Body</p>	
<b>G0M-1410-4202</b>		
<b>Eurofins Product Service GmbH</b> Storkower Strasse 38c, 15526 Reichenwalde bei Berlin, Germany, Phone +49-33631-888 000 Fax +49-33631-888 650		

Illustration 87: WLAN BWLC2





Illustration 88: WLAN BWLC2

## 10.2 Sparklan\_WUBR-508N



Illustration 89: Sparklan\_WUBR-508N



Illustration 90: Sparklan\_WUBR-508N