

Retail scale EC II Economic Class II Operating instructions

as of program version 2.10

6.107.98.5.01.44

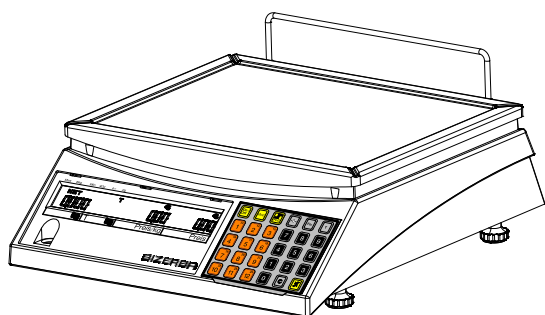

EC II 100

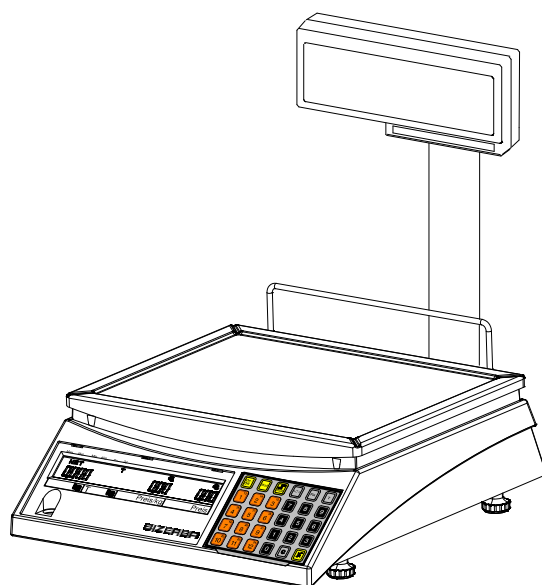

EC II 200

Alle Rechte vorbehalten
All rights reserved
Tous droits réservés
Reservados todos los derechos
Tutti i diritti riservati

© 04 / 2014

Bizerba GmbH & Co. KG,
72336 Balingen

Postfach 10 01 64
72301 Balingen/Germany,
Tel. (+49 7433) 12-0, Fax (+49 7433) 12-2696
e-mail: marketing@bizerba.com
Internet: <http://www.bizerba.com>

Chapter index	
About these instructions	1
About the device	2
Safety instructions	3
Installation	4
Device and operating controls	5
Operation	6
Programming	7
Troubleshooting	8
Maintenance	9
Technical data	10
Subject index	11

List of contents		Page
1	About these instructions	1 – 1
1.1	Safe-keeping	1 – 1
1.2	Target group	1 – 1
1.3	Symbols used	1 – 2
1.4	Presentation of menu access	1 – 2
1.5	Warnings	1 – 3
2	About the device	2 – 1
2.1	Device types	2 – 1
2.2	Accessories	2 – 1
2.3	Option	2 – 1
2.4	Intended use	2 – 1
2.5	Identification plate	2 – 2
2.6	Verification information	2 – 3
2.7	Standards and guidelines	2 – 4
2.8	Operating conditions	2 – 5
2.8.1	Power supply	2 – 6
2.9	Warranty	2 – 7
3	Safety instructions	3 – 1
3.1	Requirements on the operating personnel	3 – 1
3.2	Plates on device	3 – 1
3.3	Sources of risk related to the system	3 – 2
4	Installation	4 – 1
4.1	Transport and storage	4 – 1
4.2	Installation and assembly	4 – 1
4.2.1	Conditions for the place of installation	4 – 1
4.2.2	Assemble device	4 – 1
4.2.3	Leveling	4 – 2
4.2.4	Check electrical terminal	4 – 3
	Installation of customer-provided power supply	4 – 3
	Interference suppression measures	4 – 3

4.2.5	Connection of direct plug-in transformer unit	4 – 5
4.2.6	Rechargeable battery	4 – 6
	Operation with rechargeable batteries	4 – 7
	Operation with mains and rechargeable batteries	4 – 8
	Description of the rechargeable battery icon display	4 – 8
	Changing batteries	4 – 9
4.2.7	Battery operation	4 – 11
4.2.8	External 12V battery operation (option)	4 – 12
4.3	Commissioning	4 – 13
4.3.1	Switch device on	4 – 13
4.4	Decommissioning	4 – 13
5	Device and operating controls	5 – 1
5.1	Display	5 – 1
5.1.1	Display icons	5 – 1
5.2	Keyboard	5 – 2
5.2.1	Foil keyboard	5 – 2
5.2.2	Key funktions	5 – 3
6	Operation	6 – 1
6.1	Switch device on	6 – 1
6.2	Switch device off	6 – 1
6.3	Reset device	6 – 1
6.4	Unit price input via 10-key keypad	6 – 2
6.5	Product data call (PLU)	6 – 3
6.5.1	Direct PLU key	6 – 3
6.5.2	PLU no. input via 10-key keypad	6 – 4
6.6	Constant (fixed)	6 – 5
6.7	Tare functions	6 – 6
6.7.1	Tare balancing with the tare unknown	6 – 6
	Unknown tare	6 – 6
	Batch tare (country-related)	6 – 7
6.7.2	Tare balancing for known tare values	6 – 8
	Preset tare (country-related)	6 – 8
	PLU tare	6 – 9
	Delete tare automatically	6 – 9
	Delete tare manually	6 – 9

7	Programming	7 – 1
7.1	Initial display	7 – 1
7.2	Menu call, menu selection and exiting the menu	7 – 1
	General programming sequence	7 – 1
7.3	Product maintenance menu Pr 1 – –	7 – 2
7.4	Configuration menu Pr5 – –	7 – 5
7.5	Commissioning menu Pr6 – –	7 – 11
7.6	Service menu Pr7– –	7 – 12
	Programming overview	7 – 17
8	Troubleshooting	8 – 1
8.1	Fault description	8 – 1
8.2	Messages	8 – 2
9	Maintenance	9 – 1
9.1	Cleaning	9 – 1
9.2	Servicing	9 – 1
10	Technical data	10 – 1
10.1	Dimensions	10 – 1
10.2	Power supply	10 – 2
10.3	Environmental conditions	10 – 2
	Threshold values	10 – 2
	Index	11 – 1

Appendix

Declaration of type conformity

1 About these instructions

Read through the operating manual carefully before connecting and switching on the device to ensure that you fully utilize the quality and possibilities of application this device offers.

This operating manual explains how to operate and set the device. It also includes functions that are only required by Bizerba Service. Contact your Bizerba technical consultant if necessary.

Our products are subject to constant further development and various country-specific regulations. Pictorial and graphic examples in the instructions may differ from the supplied version.

1.1 Safe-keeping

This operating manual is an integral part of the device and must be kept next to it, easily accessible for all personnel.

If the device is resold, the complete operating manual must be provided with it.





1.2 Target group

The device may only be operated by trained personnel. This means that the operator must be familiar with the contents of this operating manual.

Installation, servicing and repairs may only be performed by qualified personnel authorized by Bizerba.

1.3 Symbols used

Various symbols are used in these instructions.

Symbol	Meaning
	Text with arrow prompts you to carry out an action.
	Key icons ask you to press this key.
 + 	Key icons with a + ask you to hold the first key pressed and then press the second key.
①	Position numbers in figures.
<key>	Text within < > describes a key.
“Display”	Text within ” ” indicates the display text.

Notes



Observance of these notes is mandatory.

Information



This information is provided for greater understanding.

1.4 Presentation of menu access

Menu settings are prerequisite for descriptions or operating processes.

Menu setting

Requirements and menu settings for functions or presets are highlighted in gray.

Pr512	0
-------	---

Input options:

Pr 512

Program number “512”

0

Setting “0”

1.5 Warnings

Warnings are divided into danger levels by the signal word.

Signal word

Icon

Meaning

DANGER



Source of danger with high risk with imminent danger for personnel!

The consequences are:

- **critical injuries**
- **severe damage to health**

Measures to avoid the danger are specified.

WARNING



Source of danger with medium risk with potentially threatening danger for personnel!

The consequences can be:

- **serious injuries**
- **damage to health**
- **serious damage to property**

Measures to avoid the danger are specified.

CAUTION



Source of danger with low risk with potentially threatening danger for personnel!

The consequences can be:

- **Injuries**
- **Damage to property**

Measures to avoid the danger are specified.

CAUTION

Source of danger, improper use!

Damage to property can result.

Measures to avoid the danger are specified.

2 About the device

In purchasing the retail scale EC II (Economic Class II) you have acquired a highly sophisticated weighing instrument that meets the highest demands. Both mains and battery operation make it suitable for universal use. For different installation situations and areas of application the EC II is available in various models.

2.1 Device types

EC II 100

Compact price-calculating scales

Fig.: EC II 100

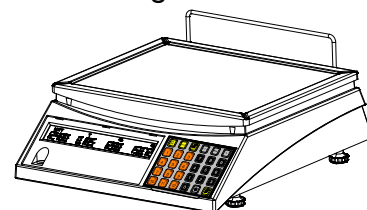

EC II 200

Price-calculating scales

With customer display in the stand

Fig.: EC II 200

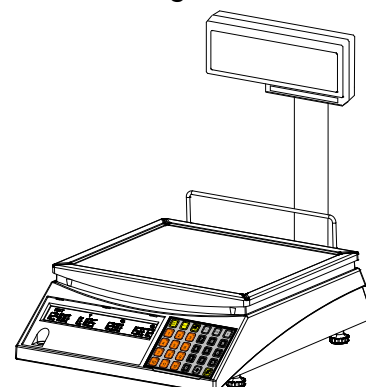

2.2 Accessories

We offer a comprehensive accessories program for the device. Please contact your Bizerba technical consultant for further information.

2.3 Option

- Rechargeable battery module

The rechargeable battery module is used to connect the battery/rechargeable battery block and also contains the battery charging circuit. It allows the scale to be battery-operated.

2.4 Intended use

The EC II scales are ideal for use particularly for on-the-counter sales and as a customer checkweigher, in mobile business applications and in goods receiving applications.

2.5 Identification plate

Identification plate of a verified scale with EC type approval.

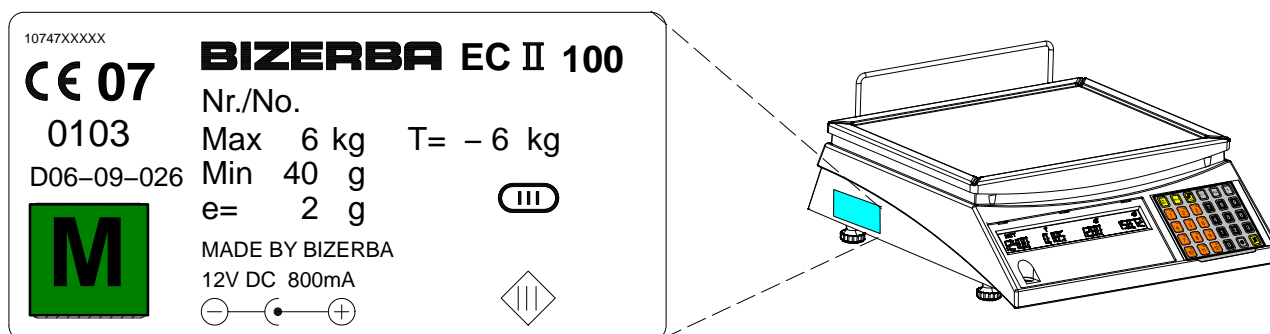

Explanations of the individual labels:

10747xxxxx	identification plate No.
CE 07	CE mark comprising the CE symbol followed by the last two digits of the year in which it was affixed
0103	identification number of the notified body that has carried out verification, e. g. 'Eichdirektion – Stuttgart'
D06-09-026	number of the EC type approval
M	green square sticker (symbol of the initial EC verification)
BIZERBA	manufacturer's name
EC II	type designation (basic type)
Nr./No.	device No.
Max 6 kg	max. capacity
Min 40 g	min. capacity 40 g
e = 2 g	verification scale interval, 2 g
T= - 6 kg	max. subtractive tare effect
MADE BY BIZERBA	Manufacturer
12V DC 800mA	electrical data
$\ominus - \bullet - \oplus$	connector for the direct plug-in transformer unit and external battery operation
III	scale accuracy class III
III (in diamond)	symbol for protective low voltage, protection class 3

2.6 Verification information

Verification information for EC countries

The green **M** (sign for EC first verification) is on the designation label of the scale. This type of scale can be put into operation and used on site providing that it is not connected to an additional device, e.g. cash register or printer.

Scales that are connected on site to an additional device (e.g. cash register or printer) must have their first verification carried out either by the responsible verification office or by a verification officer from Bizerba. Scales as well as the additional device (e.g. cash register) must be tested and verified. If the scales fulfill the verification specifications with their additional device, the additional device is also subsequently awarded a green **M** (symbol for EC first verification) and can be used in situations that require verification. In the case of extensions at a later date, once the scales have already been put into operation, the relevant verification office must be informed.

Scales and additional devices without the EC mark may not be used in situations that require verification.

Scales that are verified to a specific verification zone (acceleration of fall) (detail of verification zone are given on the designation label) may not be used in other verification zones without being reverified.

According to statutory regulations, the user of a scale must ensure that it is used for its intended purpose. This includes observation of the verification guidelines, in particular amendments, supplements and additions.

Reverification information

Reverification of scales is executed according to the respective statutory country regulations. The verification validity period in Germany, for example, is generally 2 years for scales. Price labeling scales have a verification validity period of 1 year. The verification validity period begins when the scales are put into circulation (installation and commissioning). Please refer here to the designation label (in the present example, 1999, as the designation is CE 99).

Verification information for non-EU countries

The statutory regulations of the specific countries must be observed.

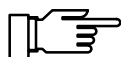

A yellow mark of conformity is affixed to the load receptor of the scale, with the inscription "Verified by BIZERBA" (first verification by Bizerba). Reverifications must be carried out by the operator of the scale according to the legal requirements.

2.7 Standards and guidelines

The equipment fulfils the following requirements:

Measuring technology

Guideline 90/384/EEC	Scales guidelines for "non-automatic scales"
OIML R76–Ed. 2006	Organisation internationale de métrologie légale Nonautomatic weighing instruments
DIN EN 45501	Metrological aspects of non-automatic scales
WELMEC 2.3	Guideline for software testing
Handbook 44	Specifications, tolerances and other technical requirements for weighing and measuring devices (USA)
Publication 14	Weighing devices, Checklist, Test procedures (USA)
Weights and Measures Act (Kanada)	

Electromagnetic compatibilit

Guideline 2004/108/EC	EMC guideline
DIN EN 61000–6–1/ 08.02	Immunity to interference Residential, commercial and light industry
DIN EN 61000–6–3/ 06.05	Emitted interference Residential, commercial and light industry
DIN EN 61000–3–2	Harmonic currents
DIN EN 61000–3–3	Voltage fluctuations and flickers
DIN EN 55011 (class B)	Industrial, scientific and medical high frequency equipment (ISM equipment) – Radio interference – Threshold values and methods of measurement.
GB 9254–1998	Information Technology Equipment – Radio Disturbance Characteristics – Limits and Methods of Measurement

Electrical safety

Guideline 2006/95/EC	Low voltage guideline
IEC 60950–1/ 2001	Information technology equipment – Safety
DIN EN 60950–1/ 03.03	Information technology equipment – Safety
UL 60950–1/ 07.06	Information technology equipment – Safety
DIN EN 60529	Housing protection classes (IP code)

2.8 Operating conditions

Do not install or commission equipment until the operating conditions have been fulfilled.

- **Temperature and air humidity:**
The permitted values and class of protection are found on the designation label on the device and on page 2 – 2.
- **Installation area**
A flat, vibration-free position as well as the driest possible installation must be guaranteed for our equipment.
Vibrations can affect measurements made by the scales.
- **Align horizontally**
To ensure the precision of the sales, it is of absolute necessity that the device is aligned horizontally.
- **Draft**
Drafts can affect the measurements made by the scales.
- **Air convection**
Free air convection must be able to form around the device in order to avoid inadmissible heating.
- **Supply voltage**
The permitted values can be found on the designation label on the device – and see page 10 – 2.
- **Trained personnel:**
Only trained personnel can maximize the performance of the device and avoid risks.
- **Written consent for modifications:**
Modifications to the devices require our prior written consent. External data dialog between Bizerba equipment and other manufacturers' equipment, the hardware and software required, test and modification work, must be clarified with us in writing.

Please contact us or our competent customer service points if you have any doubts regarding the practical application of these conditions.

For other manufacturers' equipment included in our scope of supply, the respective manufacturer's regulations take preference if they deviate from our conditions.

2.8.1 Power supply

The installation of the mains power supply for connecting to our equipment must be carried out in accordance with the international specifications and the regulations derived from them. These essentially include the recommendations of at least one of the following commissions:

- International Electrotechnical Commission (IEC)
- European Committee for Electrotechnical Standardization (CENELEC)
- Association of German Electrotechnicians (VDE)

Our units are built to VDE protection class I and must be connected to a protective conductor.

Interference suppression measures

If the mains power supply is subject to electric interference, interference suppression measures must be taken on site, e.g.:

- provision of separate mains cable to our equipment.
- in problem cases, insertion of capacitively decoupled isolating transformers or other suppressors into the mains supply lines to our equipment.

2.9 Warranty

Installation, commissioning and initial instruction must always be performed by suitably trained personnel from our sales offices and after-sales service centres or by companies commissioned by us for the purpose.

We are unable to accept any liability for damage caused as a result of:

- non-observance of Bizerba operating conditions and programming instructions.
- faulty electrical connection provided by the user.
- modification of equipment in any way from its original form.
- removal of verification and protective marks.
- improper programming and operation.
- natural wear and tear.

work carried out by anyone other than representatives authorized by us and the failure to use genuine Bizerba replacement parts or ancillary means.

When changing settings or reprogramming the equipment, always carry out a test run. This avoids unnecessary errors.

Ensure that only trained personnel operate the equipment.

Take care to train operating personnel and ensure that they fully understand the operating instructions. Repeat training.

These instructions are subject to revision as further product development, experience and investigation may show is necessary or desirable. Graphics appearing in these instructions may differ slightly from the model supplied due to country-specific regulations.

2

3 Safety instructions

The safety instructions must be observed throughout the installation, operation, cleaning and maintenance procedures.

3

3.1 Requirements on the operating personnel

The device may only be operated by people who have been instructed in the operating procedure. The operating personnel must read and understand the safety instructions in this Operating Manual.

Please pay special attention to and memorize all safety and hazard information!
Carry out regular training!

Operators (purchasers) as well as supervisory and operating staff must carry out programming and data protection on our systems and equipment exclusively in accordance with our operating and programming instructions.

3.2 Plates on device

WARNING



Selector switch NIMH– Rechargeable battery or Battery incorrectly set !

Batteries can explode.

- Set selector switch to "Battery" if batteries are being used.

Abb.: Warning note

	<p>Battery</p> <p>NIMH 1,2V NIMH 7000 mAh Size D</p>	<p>WARNUNG! Explosionsgefahr. Nur NiMH Akkus verwenden. Schalterstellung bei Verwendung von Batterien beachten.</p> <p>WARNING! Risk of Explosion! Use only NiMH rechargeable batteries. Make sure that the switch is in the right position for battery use.</p> <p>AVVERTENZA! Pericolo d'esplosione. Usare solo accumulatori NiMH. Fare attenzione alla corretta posizione dell'interruttore durante l'uso con batteria.</p> <p>AVERTISSEMENT! Danger d'explosion. Utiliser seulement des accumulateurs NiMH. Faire attention à la position correcte du commutateur en cas d'utilisation de batteries.</p> <p>¡ADVERTENCIA! ¡Peligro de explosión. ¡Utilizar sólo acumuladores NiMH. ¡Observe la posición correcta del conmutador en caso de utilizar baterías.</p>
	<p>Battery</p> <p>NIMH 1,5V Battery</p>	

3.3 Sources of risk related to the system

3

For safety reasons, shut equipment down immediately in the event of recurring faults, damage of any type, and suspicion of risk of injury. Always inform the nearest customer service point.

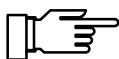

Check before mains connection

Before connecting the device, check

- the power supply data on the designation label
- the power supply data of the mains supply

WARNING



Incorrect supply voltage!

Destruction of electrical components, risk of fire.

- Do **not** connect the device to the electric mains if the power supply data do **not** match the connection values of the scale. **The power supply data must be identical.**
- Inform Bizerba Customer Service.

CAUTION



Voltage at switched-off scale!

Even when the scale is switched off, the scale electronics is live.

- Remove the AC power plug to disconnect from the mains.

WARNING



Opening the device!

Electric shock.

- The device may only be opened by trained and qualified Bizerba personnel.

4 Installation

4.1 Transport and storage

Always transport and store the scale in the original packaging.

4.2 Installation and assembly

Installation, first commissioning, adjustment, initial instruction, Maintenance and repair may only be performed by our customer service and/or by companies or persons authorized by us.

4.2.1 Conditions for the place of installation

The place of installation must fulfil the following conditions.

- A flat installation surface.
- Vibration, oscillation and draft-free installation of our device in as dry a location as possible must be guaranteed.
- The devices must be arranged so as to permit optimum operation, work sequences and maintenance.

Scale in mobile mode

Since scales used on markets are subjected to various environmental conditions, such as wind, vibrations etc., the following should be noted.

The following points must be noted in particular.

- Convey the scale to the place of use in a vertical position, resting on its foot screws. Secure it against tilting and slipping.
- Place the scale on a level and stable surface.
- Align the scale in the horizontal position by means of the foot screws with the aid of the spirit level, see Page 4 – 2.
- Operate the scale with mains connection or with batteries. When operating with batteries, ensure that the batteries are fully charged.
- Wind or vibrations may cause the display to become unstable. Set the sensitivity of the scale in the menu Pr533 , see Page 7 – 9.
- Protect the scale from humidity, rain and direct sunlight.

4.2.2 Assemble device

Unpacking

Open the packing. Remove all accessories and carefully lift the unit out of the packing.

4.2.3 Leveling

To compensate for an uneven scale supporting area, the scale may be levelled via its foot screws with the aid of a spirit level.

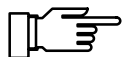
4

After each change of location, the scale must be re-levelled.

Fig.: EC II

- ① Spirit level
- ② Foot screws
- ③ Air bubble

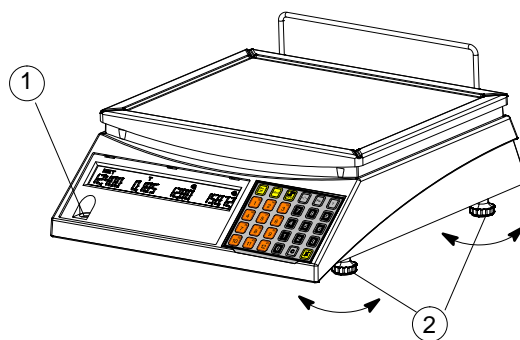
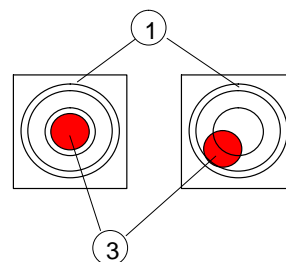

Fig.: Leveling

- ➔ Turn the foot screws ② until the air bubble ③ is located in the center of the spirit level ①.



4.2.4 Check electrical terminal

Installation of customer–provided power supply

The installation of power supply for the connection of equipment must be carried out in compliance with the international standards and the regulations applying thereto. They mainly include the recommendations of at least one of the following commissions:

- International Electrotechnical Commission (IEC)
- European Committee for Electrotechnical Standardization (CENELEC)
- Association of German Electrical Engineers (VDE)

4

Interference suppression measures

WARNING**Mains power supply !****Electric shock.**

Work on the mains power supply may only be carried out by trained and qualified personnel.

If the mains power supply is subject to electric interference, interference–suppression measures must be taken on site, e.g.:

- provide a separate power supply to Bizerba equipment.
- install a capacity–decoupled isolating transformer or similar in the power supply lines to Bizerba equipment.

WARNING**Incorrect supply voltage!****Destruction of electrical components, risk of fire.**

- Do **not** connect the device to the electric mains if the power supply data do **not** match the connection values of the scale.
The power supply data must be identical.
- Inform Bizerba Customer Service.

The equipment is manufactured according to VDE protection class III (protective low voltage) and must be connected to a direct plug-in transformer unit operating with a protective low voltage.

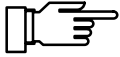
4**Check before mains connection**

Before connecting the device, check

- the power supply data on the designation label
- data on performance plate of plug power pack.

Do not connect the equipment in case of non-conformity.
Contact Bizerba after-sales service.

**Remark for power supplies:**

This product is intended to be supplied by a Listed Direct Plug-In Transformer Unit marked "Class 2" and rated 12V dc, 800mA (limited power source).

4.2.5 Connection of direct plug-in transformer unit



Protect mains cable against falling out with strain relief.

Fig.: Cable connector

4

- ① Strain relief
- ② Connection:
Cable connector of direct plug-in transformer unit
or
Connection cable of external rechargeable battery

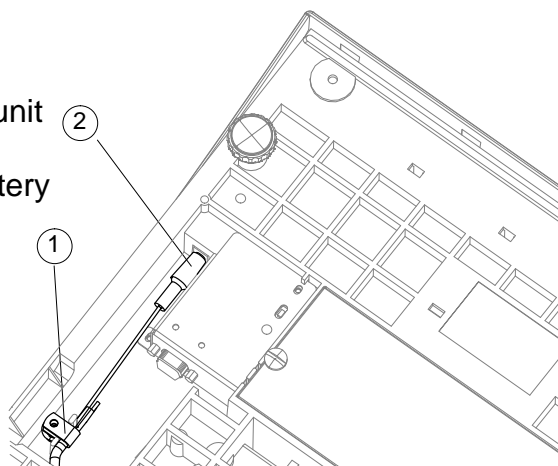

connect

- ➔ Connect the cable connector of the direct plug-in transformer unit to the bottom of the scale ②.
- ➔ Protect the cable connector against falling out or being pulled out with the strain relief ①.
- ➔ Connect direct plug-in transformer unit ③.
When the direct plug-in transformer unit is connected to the mains supply, the scale starts with the display test.

Fig.: Direct plug-in transformer unit

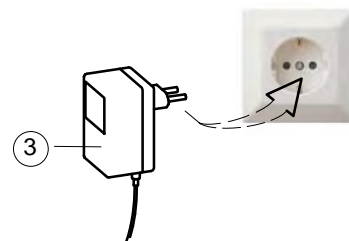

4.2.6 Rechargeable battery

The devices are available with or without rechargeable battery.

4

CAUTION

Do not use normal batteries!

- NIMH rechargeable batteries 7000 mA/h 1.2V (6 x per device) with the same rated storage capacity are required.
- Only fit rechargeable batteries from the same manufacturer and of the same type and age.
- Only leak-proof batteries may be used.

The scale can be battery-operated.

With fully charged batteries:

- approx. 120 hours, if display illumination is switched off.
- approx. 70 hours, if display illumination is switched on.



The scale can be programmed so that it switches off when it is not being used.

This means that the scale can be battery-operated for longer.

The switch-off time can be varied between 1 and 99 minutes.

Menu setting Pr531, see page 7 – 8.

Switch scale on again with <ON/OFF> key, see page 6 – 1.

Operation with rechargeable batteries

Rechargeable batteries will run down even during prolonged idle periods if the scale is not connected to the mains. Therefore, connect the scale to the mains at least every 3 months.

When the scale is operating on the mains supply, the rechargeable batteries are only recharged when the scale is switched on (trickle charging).

Overloading the batteries is prevented automatically by an integrated charging circuit. This charging circuit also prevents any damaging total discharge. The battery lifetime reduces if it is permanently operated at an almost discharged state.

4

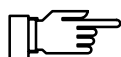

Battery lifetime

- Rechargeable batteries have a limited lifetime. As a result the capacity of the batteries decreases, as does the serviceable life of the scale in rechargeable battery operation.
- New rechargeable batteries must be fitted in order to return the scale to full power in battery operation.

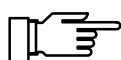

Battery charging functions

The rechargeable batteries are charged during mains operation, but only when the scale is switched on. There are 2 charging functions for charging the batteries. These can be selected in menu Pr532:

- **Charging new batteries**
New batteries require two trickle charges of 16 hours each. To do this, select Pr532=02 in the menu.
Automatic charging is reselected after each trickle charge.
 - **Automatic charging**
The batteries are automatically charged through internal measurement of the charging condition in the scale.
-

Operation with mains and rechargeable batteries

4

CAUTION

Mains operation with direct plug-in transformer unit!

Incorrect direct plug-in transformer unit will result in a faulty scale.

- The data of the direct plug-in transformer unit must agree with the data on the type plate of the scale.

Fig.: Direct plug-in transformer unit

Connect direct plug-in transformer unit ①.

The scale is supplied via the mains, and the batteries are charged at the same time.

In the event of failure of the mains supply, the scale automatically switches to rechargeable battery operation and back to mains supply as soon as the mains power supply is restored.

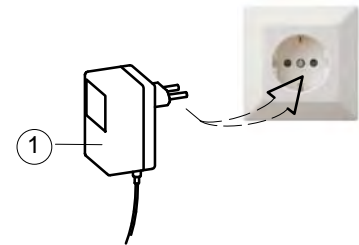



Description of the rechargeable battery icon display

Fig.: Display

⑥ Battery icon

 Battery operation / battery charging in order.

 slow flashing
mains operation / batteries charging.

 quick flashing
Warning, batteries require charging. (Depending on the age of the batteries and ambient temperature, operation can be continued for approx. 10–120 minutes in this condition).

 quick flashing
Battery voltage too low, scales will only continue to operate briefly. The warning "ACCU LO" appears in the display, then the scale switches off.

--- Battery icon not visible.
Scale on mains / batteries charged.

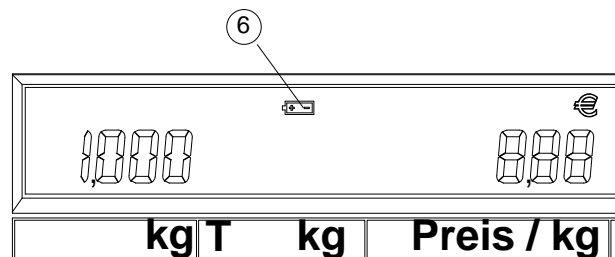

Changing batteries

CAUTION



Battery fitting position !

- When inserting the batteries, you must ensure that they are fitted in the correct position.
The symbols **+** and **–** are visible on the base of the battery compartment and on the batteries.
The position of these symbols must agree!

4

To change the batteries, a cover is located on the bottom of the scale, which is fastened with a screw.

Preparation

- ➔ Disconnect the scales from the mains and disconnect the direct plug-in transformer unit ①.

Fig.: Direct plug-in transformer unit

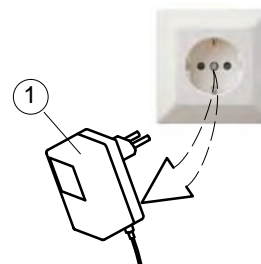

- ➔ Remove the load plate ②.

Fig.: Scale

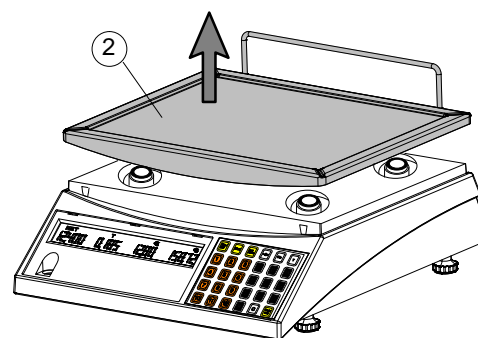

- ➔ Turn the scale over.
The battery compartment is accessible from the bottom of the scale (cover) ③.
- ➔ Unscrew the screw ④ from the cover fastening and remove the cover ③.

Fig.: Bottom of scale

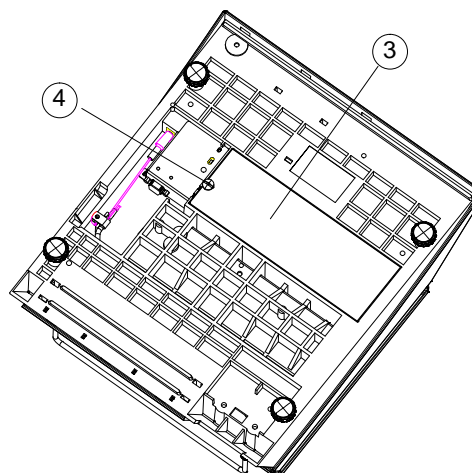

Changing

4

- ➔ Remove the empty batteries from the battery compartment ⑤.
- ➔ Insert the full batteries, ensuring the correct polarity in accordance with the symbols in the battery compartment.
- ➔ Close the battery compartment in the reverse order.

Fig.: Battery compartment

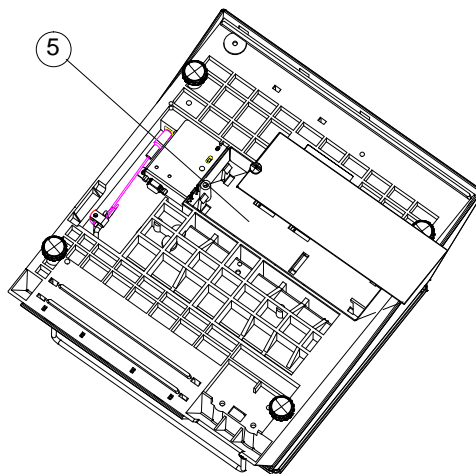

- ➔ Check the selector switch before switching the scale on. The selector switch must be set to "NIMH" if batteries are being used. The selector switch is set to battery if the sticker ⑨ is undamaged.

Fig.: Selector switch

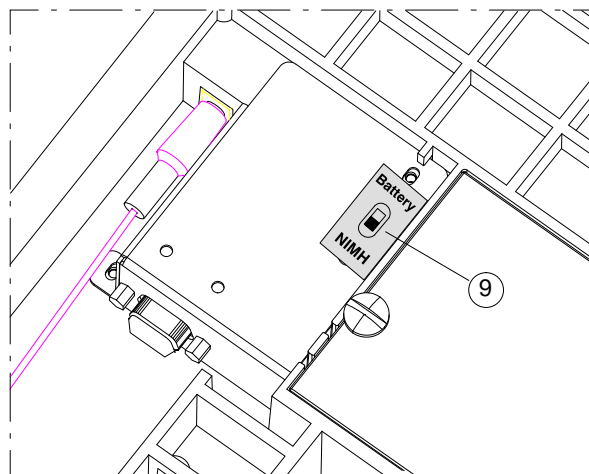

4.2.7 Battery operation

WARNING



Selector switch NIMH– Rechargeable battery or Battery incorrectly set !

Batteries can explode.

- Set selector switch to "Battery" if batteries are being used.

Fig.: Selector switch

- ⑥ Selector switch
- ⑦ "NIMH" label
- ⑧ "Battery" label
- ⑨ Sticker over selector switch

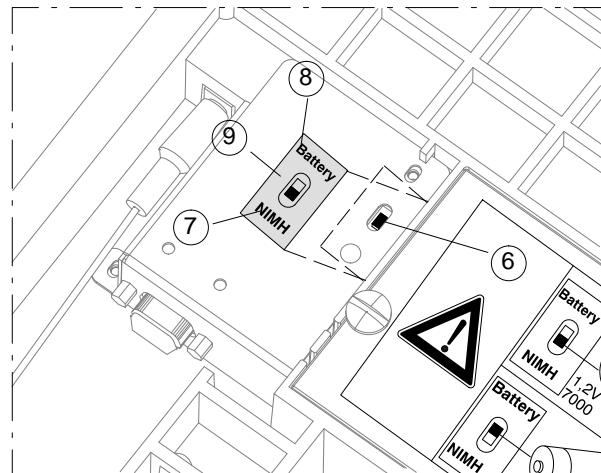

Fig.: Warning note

	<p>Battery</p> <p>NIMH 1,2V NIMH 7000 mAh Size D</p>	<p>WARNUNG! Explosionsgefahr. Nur NiMH Akkus verwenden. Schalterstellung bei Verwendung von Batterien beachten.</p> <p>WARNING! Risk of Explosion! Use only NiMH rechargeable batteries. Make sure that the switch is in the right position for battery use.</p> <p>AVVERTENZA! Pericolo d'esplosione. Usare solo accumulatori NiMH. Fare attenzione alla corretta posizione dell'interruttore durante l'uso con batteria.</p> <p>AVERTISSEMENT! Danger d'explosion. Utiliser seulement des accumulateurs NiMH. Faire attention à la position correcte du commutateur en cas d'utilisation de batteries.</p> <p>¡ADVERTENCIA! ¡Peligro de explosión. ¡Utilizar sólo acumuladores NiMH. ¡Observese la posición correcta del conmutador en caso de utilizar baterías.</p>
	<p>Battery</p> <p>NIMH 1,5V Battery</p>	

4.2.8 External 12V battery operation (option)

The scale can be operated with an external rechargeable battery. To do this, the external battery is connected to the power supply input via a connection cable.

The power source (external battery) must meet the requirements of the power limiter complying with UL 60950 and IEC 60950-1: 2001, section 2.5.

Connection example

- ⑨ Connection cable $\ominus \text{---} \bullet \text{---} \oplus$.
The connection (Limited power source) must be protected with a 4A fuse.

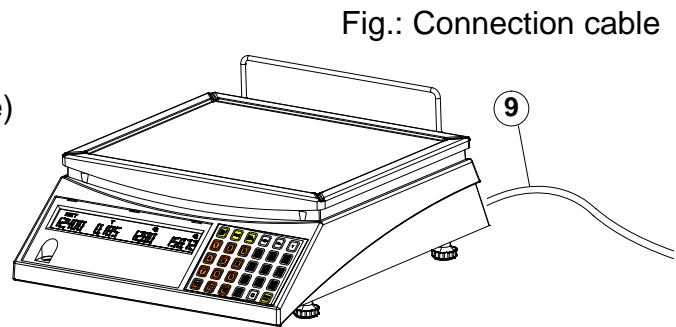

- ⑩ Connection:
Cable connector of direct plug-in transformer unit
or
Connection cable of external battery

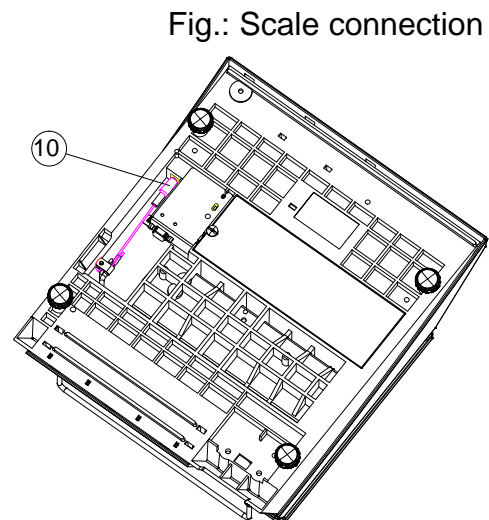

External battery operation

- Disconnect the cable together with the direct plug-in transformer unit on the scale underside ⑩.
- Link the connecting cable to a 12 V socket.
- Link the connecting cable to the scale underside ⑩.

Mains operation

- Disconnect the connecting cable on the scale underside ⑩.
- Connect the cable together with the direct plug-in transformer unit to the scale underside ⑩.
- Connect the direct plug-in transformer unit to the socket.

4.3 Commissioning

The initial installation and commissioning as well as instruction in the operation, cleaning, care and maintenance will be carried out by the responsible Bizerba Customer Service Agent or the Bizerba specialist adviser.

4

4.3.1 Switch device on

Requirement:

- The device was installed properly and connected to the mains.
- The scale should not be loaded.

Fig.: Keyboard

① ON/OFF key 

The scales are switched on and off via the <ON/OFF> key.

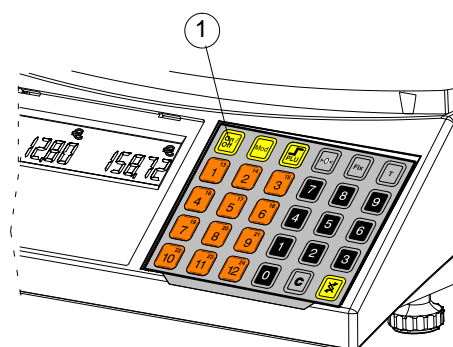

4.4 Decommissioning

If you wish to decommission the scale for a prolonged period of time,

- Switch the scale off.
- Disconnect scale from mains (unplug plug power pack).
- Remove the direct plug-in transformer unit from the bottom of the scale.
- Remove the batteries or rechargeable batteries from the battery compartment.
- Clean the scale in accordance with the cleaning instructions.

4

5 Device and operating controls

5.1 Display

The display is divided into:

- ① Symbols
- ② 6–digit selling price
- ③ 6–digit unit price
- ④ 4–digits with or without tare value
- ⑤ 5–digit weight value

5

Fig.:Display

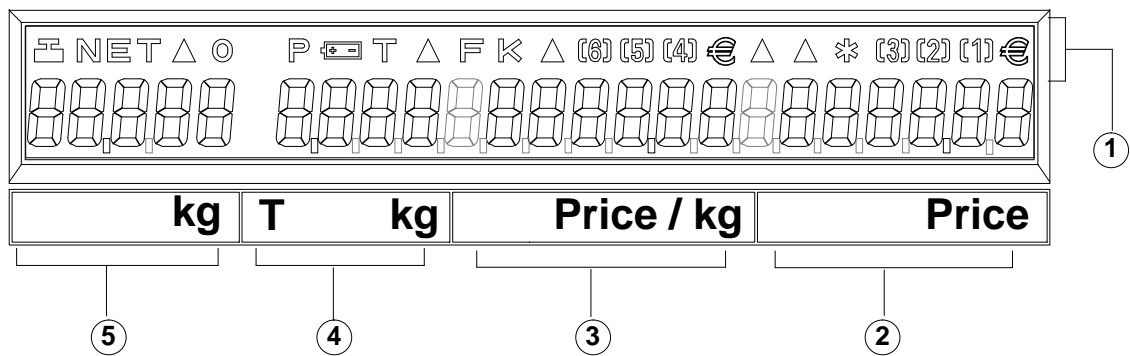

5.1.1 Display icons

The type and country–dependent symbols are used to identify the various operational states:

- NET** = net display after the taring procedure
- = exact zero
- P** = prepack
-  = battery operation/battery load control (see LEERER MERKER)
- T** = tared weight value after the taring procedure
- F** = fixed unit price
- K** = constant unit price
- △ = illuminated symbols to indicate different functions

5.2 Keyboard



The keyboard versions are country-related.

5

5.2.1 Foil keyboard

The foil keyboard has a transparent section where the keyboard labeling can be inserted if required.

- ① Foil keyboard
- ② Keyboard labeling

Fig.: Foil keyboard

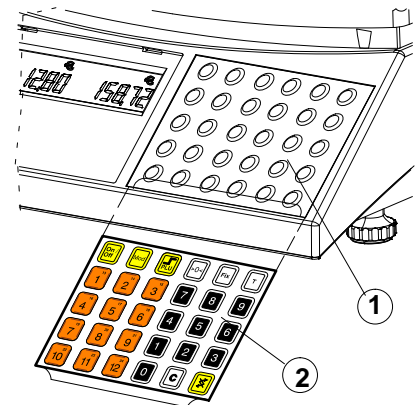

- ③ 10-key keypad
- ④ PLU direct keys
- ⑤ Function keys

Fig.: Keyboard labeling

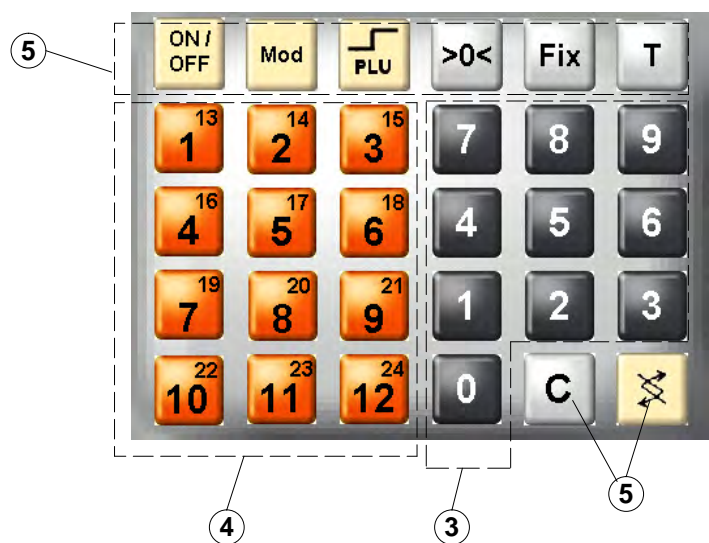

5.2.2 Key functions

Key function

 10-key keypad
 Input:
 unit price,
or
 PLU
or
 tare value

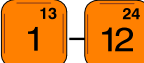
 PLU-Direkt-Tasten (PLU-Nr 1- 12 / 13- 24)

Function keys

Key function

 Switch scales on/off

 Call menu / quit menu

 Switch 10-key keypad
 Unit price input
or
 Enter PLU no. or tare fixed value memory

 Switch the PLU-direct keys to the next level (PLU no. 13-24)

 Switch display lighting on or off.

 Fixed
 depending on the menu setting:
 Unit price
or
 Tare value,
or
 Unit price and tare value

 Tare

 Zero setting of scale

 Delete input (clear)

5

6 Operation

- ① Key <ON/OFF>
- ② Key <Zero setting>

Fig.: Keyboard

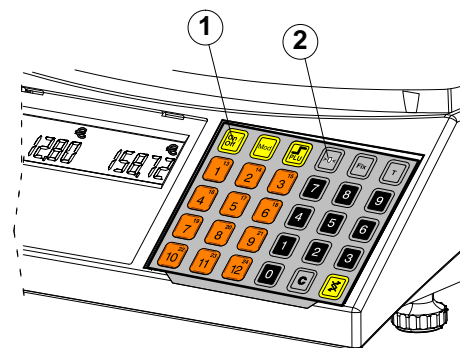

6

6.1 Switch device on

The scale should not be loaded.



Press key <ON/OFF> until a signal sounds.

The display test is automatically run. All figures and icons are displayed for approx. 5 sec..

After that and with no weight on the load receptor, the weight value display moves automatically to zero "0.000 kg" and will be ready to operate.

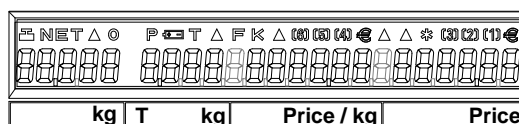

6.2 Switch device off

Unintentional switch-off of the scale is not possible.

If key <ON/OFF> is pressed for a long time, "OFF 3" occurs on the display.

The scale counts backwards "OFF 3"– 2– 1.

After that the display turns black and the scale switches off.



Press the <ON/OFF> key until the display goes dark.

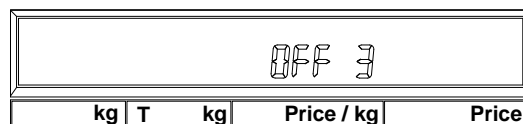

If the key is released too soon, the scale will start the display test.

6.3 Reset device

Switching on the scale causes the weight display to move automatically to zero "0.000" kg, provided that there is no load on the load receptor.

The scale is equipped with an automatic zero setting device, small zero point drifts are automatically compensated for.

With no load on the load receptor, the weight value display may be reset to zero (if deviating from zero).



Press the <Zero setting> key.

6.4 Unit price input via 10-key keypad

- ① 10-key keypad
- ② Selling price display
- ③ Unit price display

Fig.: 10-key keypad

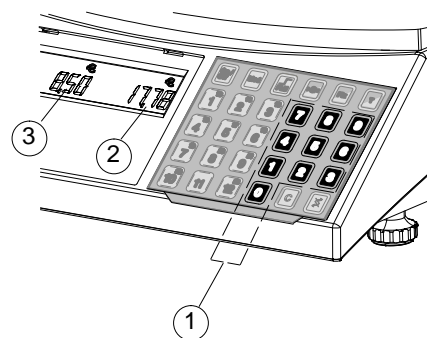

6

Example:



Place the product on the scales.



Enter the unit price, e.g. 8.50.
Read off the selling price.

2,092	8,50 €	17,78 €
-------	--------	---------



Remove the product from the scales.
Unit and selling price are deleted.

0,000	0,00 €	0,00 €
-------	--------	--------

6.5 Product data call (PLU)

PLU = Price Look Up

The PLU no. contains the product data, e.g. product unit price and/or product-tare.



Prerequisite for a PLU call is PLU programming in the Pr110 menu (unit price) and the Pr113 menu (tare values).

The PLU call can be implemented by two methods:

- Direct PLU key
- PLU no. input via 10-key keypad

6

6.5.1 Direct PLU key

The PLUs 1 to 12 can be called directly via the PLU keys ③.

Fig.: Direct PLU key

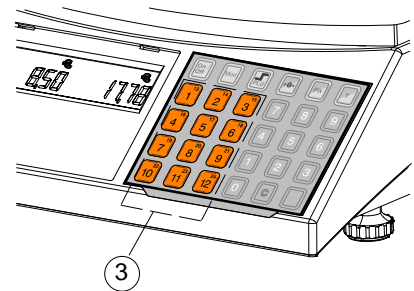

PLU 1 – 12



Press a PLU key, e.g. <1>.

The PLU 1; saved value, e.g. unit price "8.50" appears in the display.

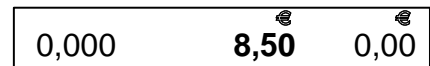

PLU 13 – 24

The PLUs 13 – 24 can be directly accessed after switching to <PLU level>.



Press the shift key <PLU level> .

In the display you can see "△": switchover is activated.

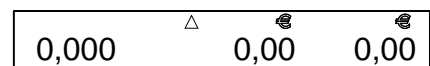
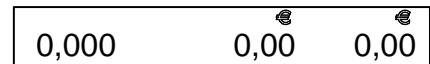

Press a PLU key, e.g. < 1 ⁽¹³⁾ >.

The PLU saved value 13 is displayed, e.g. unit price "13.50".

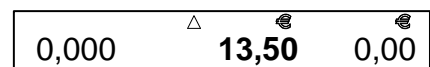

6.5.2 PLU no. input via 10-key keypad

The 10-key keypad can be switched from unit price input to PLU no. input.

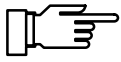

Whether you can switch depends on the Pr 512 menu setting, see page 7 – 5.

Switching is implemented by using the  key.

6

Example: Pr512 menu setting = 0. PLU 1 unit price 8.50 .



Switch over to PLU no. input.

PLU ____





Enter the PLU no.

PLU __1





Press the <Fix> key.

Content of the PLU is displayed.

0,000	8.50 	0,00 
-------	--	--





Place the product on the scales.
Read off the selling price.

2,092	8,50 	17,78 
-------	--	---



Remove the product from the scales.
Unit and selling price are deleted.

0,000	0,00 	0,00 
-------	--	--

6.6 Constant (fixed)

A fixed constant can, for example, be used for several consecutive sales of the same product.



Fixing a constant is dependent on the Pr 514 menu setting.

Constant fixing of:

Unit price

or

Tare value

or

Unit price and tare value

Switch on fixing function



Press the <Fix> key.

The "K" or "F" icon lights up (depending on country).

After removing the load from the scales the current value remains fixed.

Switch off fixing function



Press the <Fix> key again.

The "K" or "F" icon light goes off (depending on country).

After removing the load from the scales the display shows a zero.

Example: Pr 514 menu setting = 0.



Press the <Fix> key.



Place the product on the scales.



Enter the unit price, e.g. 8.50.

Read off the selling price.

2,092	K	8,50 [€]	17,78 [€]
-------	---	-------------------	--------------------



Remove the product from the scales.

The unit price is not deleted.

0,000	K	8,50 [€]	0,00 [€]
-------	---	-------------------	-------------------

6.7 Tare functions

6.7.1 Tare balancing with the tare unknown



An unknown tare weight (empty container) is a non-PLU-related tare which is to be weighed and tared.

- Scales having a weighing range below 10 kg allow the full range to be tared.
- Scales the weighing range of which exceeds 10 kg allow taring of up to max. 9,995 kg (max. 4-digit) only (country-related).
- The tared value will be subtracted from the total weighing range.
- A taring command is directly executed only when the weight indication has stabilized.
- If an unknown tare value has been tared by means of key <Tara> this value may not be overwritten by a known tare (preset tare, PLU tare).
- After an unknown tare value has been balanced, a PLU call with the PLU tare is possible. The PLU tare will then, however, be ignored.

6

Unknown tare

Weighing of a PLU item into an empty container with an unknown tare weight.

Fig.: Unknown tare

➔ Place the empty container on the scales.
The weight display ① indicates the weight of the empty container, e.g.: "0.535" kg.



Press the <Tare> key.

The tare-display ② shows the weight of the empty container, "0.535" kg.

The weight display ① shows zero.

➔ Fill the empty container with the product.
The weight display ① indicates the net weight of the product "2.000" kg.
The tare-display ② shows the weight of the empty container, "0.535" kg.

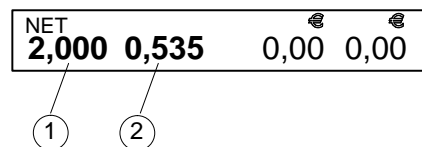
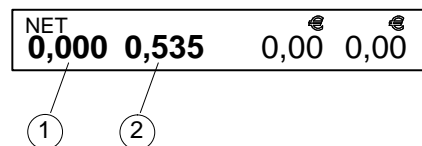
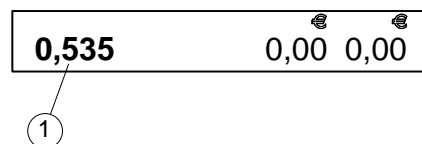

Batch tare (country-related)

Determine unknown tare, weigh product, add this to the tare weight and weigh the next product net.

Fig.: Batch tare

➔ Place the empty container on the scales.
The weight display ① indicates the weight of the empty container, e.g.: "0.535" kg.

 Press the <Tare> key.
The tare-display ② shows the weight of the empty container, "0.535" kg.
The weight display ① shows zero.

➔ Fill the empty container with the product.
The weight display ① indicates the net weight of the product "0.800" kg.
The tare-display ② shows the weight of the empty container, "0.535" kg.

 Press the <Tare> key.
The weight of the product and the empty container are added to the new tare weight ②.
The weight display ① shows zero.

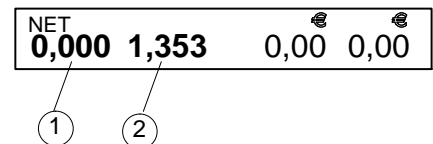
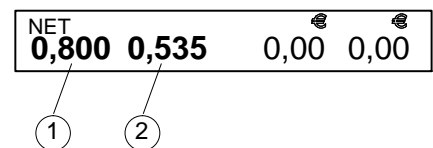
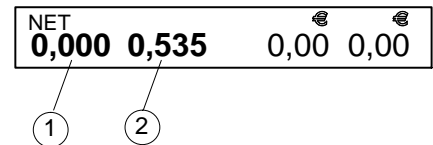
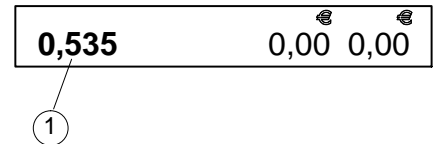

For scales under 10 kg you can tare the entire weighing range.

6.7.2 Tare balancing for known tare values



Known tare

- When weighing a packaged PLU item, the tare value must be known (package/PLU-related tare).
- In the case of multi-interval scales the known tare value must be within the partial weighing range having the smallest scale interval (country-related).
- A known tare value (entered) cannot be overwritten by an unknown (weighed) tare.
- It may be entered in two different ways, i. e.
 1. as a preset tare
 2. via a PLU tare

6

Preset tare (country-related)



In various countries, a preset tare is not allowed.

The scales should not be loaded. Weight value "0.000" kg.



Press the <Tare> key.

The manual tare input is opened.

0,000	_,__	0,00	0,00
-------	------	------	------



Enter the known tare value,
e.g. 0.500 kg.

0,000	_,500	0,00	0,00
-------	-------	------	------



Press the <Tare> key.

The tare value is accepted.
Tare and net weight value display.

NET		0,00	0,00
-0,500	0,500	0,00	0,00

PLU tare

Menu setting

- Menu Pr113
Allocate the known tare value to the respective PLU product.

The PLU tare value is activated and displayed via the PLU call.
For PLU call, see page 6 – 3.

Example: A tare value of 500 g is saved in PLU no. 9.

-  Press a PLU direct key e.g.: <9>.
- The saved tare is activated and displayed.

NET		€	€
-0,500	0,500	0,00	0,00

Delete tare automatically

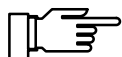

The automatic tare deletion depends on the Pr514 menu setting, see page 7 – 6, and the constant function, see page 6 – 5.

Example: Menu Pr514 = "0".
Tara 500g.
Unit price 1.80€
The <Fix> key is not activated.

- ➔ Place the product on the scales.
Read off the selling price.

NET		€	€
0,800	0,500	1,80	1,44

- ➔ Unload the scale.
The display is set to zero.

	€	€
0,000	0,00	0,00

Delete tare manually

- ➔ Unload the scale.

 Press the <Tare> key.

or

 Press the <Clear> key.
The display is set to zero.

	€	€
0,000	0,00	0,00

6

7 Programming

7.1 Initial display

- ① Net weight display
- ② Unit price display
- ③ Selling price display

If the display is occupied, activate the  key.

Fig.: Initial display



7.2 Menu call, menu selection and exiting the menu

The menu is called up with the scale display in the initial position.

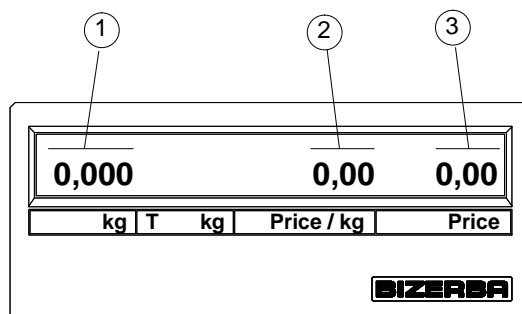
- ④ Input field for menu selection
- ⑤ Input field for functions

Fig.: Menu display

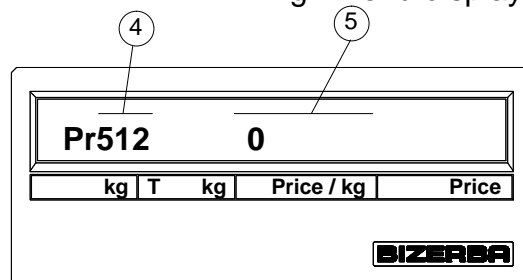

General programming sequence

Menu invocation

 Call up menu.

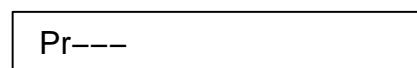

Menu selection

   Select menu.

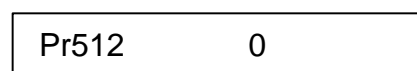

Make setting.

 e.g. set function <1>.

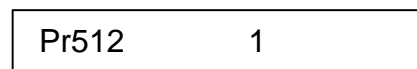

 Confirm with <Fix> key.

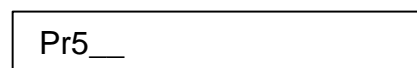

Exit menu

 Exit menu.

The scale returns to its initial display.

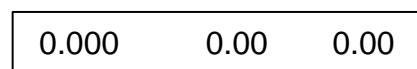

Product maintenance Pr 1--

7.3 Product maintenance menu Pr 1 – –

200 products (PLU) can be saved to Pr110 with a unit price and saved to Pr113 with a tare value.

This PLU memory can also be used as a tare value memory; no unit prices are permitted here.



Set PLU unit price	Pr 110
Set PLU tare value	Pr 113
Delete individual PLU products	Pr 171
Delete complete PLU product pool	Pr 172

7

Set PLU unit price Pr110

Example: PLU no. 2 should be allocated a unit price of 12.50 Euro.



Press the <Mod> key.

Pr---

The scales are in programming mode.



Select the menu via the 10-key keypad.

Pr110 001



Enter the product (PLU) no.

Pr110 __2



Confirm with the <Fix> key.

Pr110 0000,00



Enter the unit price.

Pr110 __12,50



Confirm with the <Fix> key.

Pr110 003

The next PLU no. is displayed.

or

The next assigned PLU no. is displayed.



Press the <Mod> key.

0,000 0,00 0,00

The scales are back in weighing mode.

Set the PLU tare value







Pr113



The maximum tare value depends on the load capacity.
 Multi-interval scales permit taring operations in the first partial weighing range only,
 e. g. weighing range 6/15kg – permitted tare range 0–6 kg.

7

Example: the PLU no 2 should be allocated a set tare value of 150 grams.

	Press the <Mod> key. The scales are in programming mode.	Pr----
	Select the menu via the 10-key keypad.	Pr113 001
	Enter the product (PLU) no.	Pr113 __2
	Confirm with the <Fix> key.	Pr113 0.000
	Enter the tare weight (in grams).	Pr113 __,150
	Confirm with the <Fix> key. The next PLU no. is displayed. or The next assigned PLU no. is displayed.	Pr110 003
	Press the <Mod> key. The scales are back in weighing mode.	0,000 0,00 0,00

Delete individual PLU products

Pr171



Press the <Mod> key.

Pr---



Select the menu via the 10-key keypad.

Pr171 001

7



Enter the product (PLU) no.

Pr171 __2



Delete the product (PLU) 002 with the <Fix> key.

Pr1--



Press the <Mod> key.

0.000 0.00 0.00

Delete the complete PLU product pool

Pr172

CAUTION

Loss of data!

All PLU product data is being deleted.



Press the <Mod> key.

Pr---



Select the menu via the 10-key keypad.

Pr172 0



Delete all products with the <Fix> key.

Pr172 0

Wait until the display switches back.

Pr1--



Press the <Mod> key.

0.000 0.00 0.00

7.4 Configuration menu Pr5 --



Configuration menu overview

10-key keypad for unit price or entering PLU input	Pr 512
Constant key function	Pr 514
Set zeros in price input	Pr 522
Control display lighting	Pr 530
Turn-off function	Pr 531
Battery charging function	Pr 532
Scale (display) sensitivity	Pr 533
Error display or automatic reset	Pr 534
Switching from local currency to Euro	Pr 595



10-key keypad for unit price or PLU input

Pr512

Pr512

0

Input possibilities:

- 0** = Unit price input via 10-key keypad.
 Switch to PLU no. input
- 1** = LU no.- Input via 10-key keypad.
 Switch to unit price input.
- 2** = Only PLU no. input via 10-key keypad.
 Unit price input is not possible.

Constant key function

Pr514

Pr514	0
-------	---

Input possibilities:

- 0 = Only fix the unit price on sale
- 1 = Only fix the tare value on sale
- 2 = Fix the unit price and the tare value on sale

7

Set zeros in price input

Pr522

Pr522	0
-------	---

Input possibilities:

- 0 = No set zero
- 1 = One set zero, acceptance of price input is after the first zero.
- 2 = Two set zeros, acceptance of price input is after the second zero.
- 3 = Three set zeros, acceptance of price input is after the third zero.

Examplee:

Exit display

0,000	0,00	0,00
-------	------	------

1 = One set zero



Input via the 10-key keypad

0,000	1,10	0,00
-------	-------------	------

2 = Two set zeros



Input via the 10-key keypad

0,000	11,00	0,00
-------	--------------	------

3 = Three set zeros



Input via the 10-key keypad

0,000	110,00	0,00
-------	---------------	------

Control display lighting**Pr530**

Pr530	00
-------	----

Input possibilities:

00 = the display lighting can be switched on and off manually.



Press and hold down key <PLU level>

then press key <Switch>

If the display lighting is switched on manually, it stays on.

7

Switch the display lighting off manually, before you set the time for automatic display control.

01–99= Display lighting is automatically switched off and on.

Automatic:

After the last action performed at the scales, the display lighting switches off automatically after a period of between 1 to 99 seconds.

Setting 01 display off after approx. 1 second.

Setting 99 display off after approx. 99 seconds.

When another action begins at the scales, the display lighting is switched on again automatically.

Turn-off function**Pr531**

Pr531	00
-------	----

Input possibilities:**00** = Scale is not turned off.

01–99= Battery operation: Turn-off time in minutes, if no action occurs on the scale.
 Mains operation: Observe the setting in Pr792. Turn-off function active or inactive.

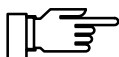
7

Switch the scale on again by pressing the <ON/OFF> key.

If the turn-off time is set to > 10 min., the scales go into power-saving mode after a time set in menu Pr793. "SLEEP" appears in the display.

If any key is pressed, the scale is ready for operation again after approx. 3 sec. .

Battery charging function**Pr532**

Pr532	0
-------	---

Input possibilities:**0** = No charging**1** = Automatic charging

The batteries are automatically charged through internal measurement of the charging condition in the scale.

2 = Trickle charging for new batteries

New batteries require two trickle charges of 16 hours each. Automatic charging is reselected after each trickle charge.

Scale (display) sensitivity

Pr533

The sensitivity setting regulates damping in the event of vibrations at the place of installation (e.g. market operation).



The higher the setting, the longer the time until standstill of the display.

7

Pr533	0
-------	---

Input possibilities:

- 0 = display sensitive (standard) in stable, vibration-free supporting area
 - 1 =
 - 2 =
 - 3 =
 - ..
 - ..
 - 8 =
 - 9 =
- ↓ the sensitivity decreases

Error display or automatic reset

Pr534

Pr534	0
-------	---

Input possibilities:

- 0 = Automatic reset if weight value is below zero (after approx. 5 seconds).
- 1 = Error display "Cod 115" if weight value is below zero (after approx. 5 seconds).
- 2 = No automatic reset and no error display if weight value is below zero.

Switch from local currency to Euro

Pr595

For the countries that are approved for Euro conversion, the scale can switch from their local country to Euro.

Display data in local currency

7

- ① Display fields in local currency e. g. Ft
- ➔ Remove the sticker with the local currency from the display

Fig.: Sticker with local currency

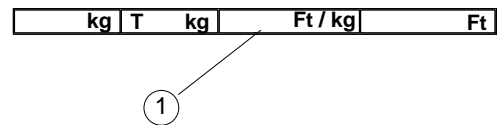

Change menu



Input possibilities:

- 0 = Local currency
- 1 = Euro



Press key <Fix>. Re-start scale. Saved PLU unit prices are not converted.

The scale is set to Euro

Fig.: Start-up display Euro

- ② Euro symbol
- ③ Language in display field

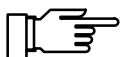
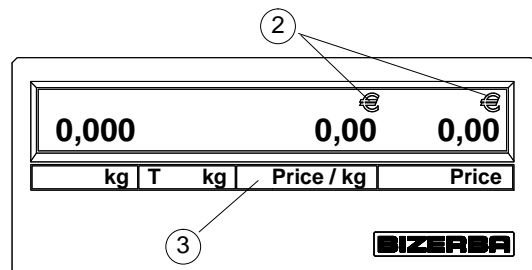

After RAM clearing the local currency is a standard default.

7.5 Commissioning menu Pr6 --

Commissioning

Pr666

During commissioning all PLU data is deleted and all settings are set to standard.

CAUTION

loss of data!**All PLU product data is being deleted.**

7



Press the <Mod> key.

Pr---



Select the menu via the 10-key keypad.

Pr **666** 00

On the 10-key keypad, press the <8> and <1> keys.

Pr 666 **81**

Press the <Fix> key.

Wait until the scales start the display test again and they are reverted to weighing mode.

0.000 0.00 0.00

Service Pr 7--

7.6 Service menu Pr7- -

Display ADC program version	Pr712
Display the load cell type	Pr715
Display main program version	Pr716
Logbook control	Pr730
Activate/deactivate turn-off function in mains operation	Pr792
On-period of power-saving mode (SLEEP)	Pr793

7**Display ADC program version****Pr712**

Pr712	6026500003
-------	------------

Display example: _____

Display of load cell type**Pr715**

Pr715 Cod 60201

Display example:

Display text	Load cell type	Load capacity	Scale interval
Cod 120201	WS18,WS36	12kg	2g
Cod 150501	WS18,WS36	15kg	5g
Cod 150502	WS18,WS36	6/15kg	2/5g
Cod 150503	WS18	6/15kg	2/5g
Cod 151501	WS18, WS12	15lb	0,005lb
Cod 150201	WS18	15kg	2g
Cod 252111	WS18	25lb	1/8 oz
Cod 030011	WS36	30kg	10g
Cod 301111	WS18,WS36	30lb	0,01lb
Cod 301112	WS18,WS36	15/30lb	0,005/0,01lb
Cod 301113	WS18	15/30lb	0,005/0,01lb
Cod 301501	WS18,WS36	30lb	0,005lb
Cod 300501	WS36	30kg	5g
Cod 300111	WS36	30kg	10g
Cod 300112	WS36	15/30kg	5/10g
Cod 300113	WS36	15/30kg	5/10g
Cod 060101	WS18, WS12	6kg	1g
Cod 060201	WS18, WS12,WS36	6kg	2g
Cod 060202	WS18, WS12	3/6kg	1/2g
Cod 060203	WS12	3/6kg	1/2g
Cod 601111	WS36	60lb	0,01lb
Cod 601211	WS36	60lb	0,02lb
Cod 601212	WS36	30/60lb	0,01/0,02lb

Display main program version

Pr716

Pr716 00361077200100

Display example:

7

Logbook control

Pr730

Information can be requested from the logbook in menu 730.

 Invocation of 1st step with the <Fix> key.

 Invocation of information with the <shift key>.

Overview of logbook information

Step 1 Software identification number. (Software ID)



Step 2 Entries in the logbook.
The display of entries is divided into several steps.

21	Consecutive number of the logbook entry, Department number, Component number.
22	Version number of the loaded software.
23	Date and time of the download.

Invocation of logbook entries

 Press the <Mod> key.

Pr----

   Select the menu via the 10-key keypad.

Pr730 0

 Press the <Fix> key for step 1.

Pr730 1 EC 01

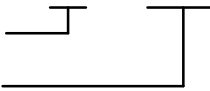
Step display 
Software ID

Press the <shift key> for the other steps.



Step 21

Pr730 21 2 20 10

Serial number of the entry _____
 Department number _____
 Component number _____



Step 22

Pr730 22 00011077400001

Version number of the loaded software _____



Step 23

Pr730 23 260906 1057

Date _____
 Time _____

If there are further entries in the logbook, the next entry is displayed in the next step.



Step 21

Pr730 21 1 20 10

Serial number of the entry _____
 Department number _____
 Component number _____



Step 22

Pr730 22 00011077400099

Version number of the loaded software _____



Step 23

Pr730 23 270706 1350

Date _____
 Time _____

Steps 21 to 23 are repeated until all logbook entries have been displayed.
 Once all entries have been displayed, the scale returns to the menu output display.



Pr7--

Activate/deactivate turn-off function in mains operation**Pr792**

In menu Pr 792 the turn-off function is activated or locked in Pr531 for mains operation.
See also Pr 531 page 7 – 8.

Pr792	1
-------	---

Input possibilities:

0 = Turn-off function during mains operation inactive.

1 = Turn-off function during mains operation active.

7**On-period of power-saving mode (SLEEP)****Pr793**

If a turn-off time >10 minutes is set in menu Pr531, the ADC is put into power-saving mode after approx. 3 minutes as standard. This time can be set as you wish via the Pr793 menu.
See also Pr 531 page 7 – 8.

Pr793	03
-------	----

Input possibilities:

03 = Time in minutes, (00–99)







If a time of 00 minutes is set, power-saving mode is not executed.

If a time is set that is greater than the turn-off time in Pr531, power-saving mode is also not executed.

Programming overview

Product maintenance	Setting option	Menu	see page
Set the PLU unit price	PLU number Unit price	Pr 110	7 – 2
Set the PLU tare value	PLU number tare in grams	Pr 113	7 – 3
Delete individual PLU products	PLU number	Pr 171	7 – 4
Delete the complete PLU product pool	All saved products (PLU) are being deleted.	Pr 172	7 – 4

7

Configuration	Setting option	Menu	see page
10-key keypad for entering unit price or PLU input	0 Unit price input via keypad Switch to PLU no. input	Pr 512 	7 – 5
	1 PLU no. Input via keypad Switch to unit price input		
	2 PLU no. (It is not possible to switch)		
Fixed Key function	0 Fix unit price	Pr 514 	7 – 6
	1 Fix tare		
	2 Fix unit price and tare		
Set zeros in price input	0 no set zero 0,00	Pr 522	7 – 6
	1 one set zero 0,00		
	2 two set zeros 0,00		
	3 three set zeros 0,00		
Control display lighting	00 Manual switch on/off	Pr 530  	7 – 7
	01–99 Automatic switch on/off 01=1sec./ 99=99sec.		
Turn-off function	00 Scale is not turned off	Pr 531	7 – 8
	01–99 Turn-off time after min.		
Battery charging function	0 No charging	Pr 532	7 – 8
	1 Automatic charging		
	2 Trickle charging		

Configuration	Setting option	Menu	see page
Scale (display) sensitivity	0 –9	Pr 533	7 – 9
Error display or automatic reset	0 Automatic reset 1 Error display 115 (after 10sec) 2 No reset, kno error display	Pr 534	7 – 9
Switch from local currency to Euro	0 Local currency 1 Euro	Pr 595	7 – 10

Commissioning		Menu	see page
RAM – deletion	<ul style="list-style-type: none"> – All saved products (PLU) are being deleted. – The scales are reset to standard settings 	Pr 666 	7 – 11

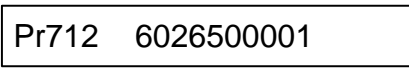
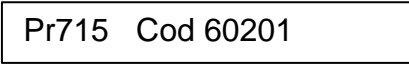
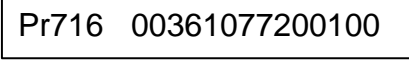
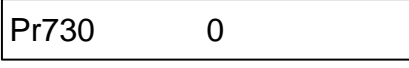
Service	Example of display	Menu	see page
Display the ADC program version		Pr 712	7 – 12
Display the load cell type		Pr 715	7 – 13
Display the main program version		Pr 716	7 – 13
Logbook monitoring		Pr730	7 – 14
Turn-off function in mains operation	0 Turn-off function during mains operation inactive. 1 Turn-off function active during mains operation	Pr 792	7 – 16
On-period Power-saving mode (SLEEP)	03 Time in minutes (0–99 min)	Pr 793	7 – 16

8 Troubleshooting

Basically the listed faults can be remedied by yourself.

If you experience problems which you cannot solve yourself or problems which are not described in these operating instructions contact your competent Bizerba after-sales service.

To facilitate relevant service calls, please submit the following information to the after-sales service:

- device type (see identification plate)
- device number (see identification plate)
- Fault description

This facilitates preparation work to be carried out by the after-sales service.

8.1 Fault description

8

FAULT	CAUSE	RECTIFICATION
Display does not light up.	No voltage No battery voltage or battery empty	Check direct plug-in transformer unit and connect it. Check connector for direct plug-in transformer unit/ connecting cable. Check rechargeable batteries/ battery. Charge rechargeable batteries/battery. Switch the scale off and back on.
Weight value display not on zero or not stable.	Load plate not properly attached, or foreign objects are deposited on it. Dirt has accumulated on or underneath the load plate. Scale not levelled.	Ensure that the load plate is properly attached and that it is free of foreign objects. Clean the load plate. Level the scale. Switch the scale off and back on.

8.2 Messages

Operating errors or faults in the electronics are indicated by "Cod" and an error code digit.

Display

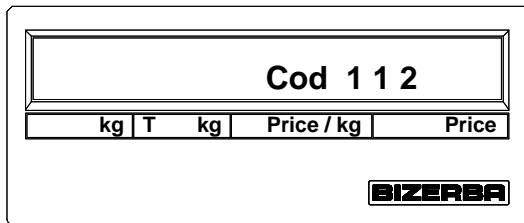

8

Messages	Cause	Rectification
Cod 112	Scale in motion during startup.	Do not move the scale during the startup procedure!
Cod 115	Scale below zero.	Activate the 'C' key or switch the scale off and back on by activating the 'ON/OFF' key. Check the error suppression in the Pr 534 menu.
Cod 110	Scale loaded during startup.	Unload scale! Activate the 'C' key or switch the scale off and back on by activating the 'ON/OFF' key.
Cod 110	Scale below zero during startup.	Attach load plate! Activate the 'C' key or switch the scale off and back on by activating the 'ON/OFF' key.
Other error code numbers	---	Activate the 'C' key or switch the scale off and back on by activating the 'ON/OFF' key.

9 Maintenance

9.1 Cleaning

The cleaning instructions must be observed during installation, operation and maintenance.

CAUTION

Wrong detergent!

Damage of the device surface.

Do not use spirit, acetone or aggressive cleaning or scouring agents.

CAUTION

Cleaning!

Penetrating water may cause damage to the device.

Make sure that no water runs into the device when cleaning.

9

Use warm water with dish-washing detergent (food safe) for cleaning. Use a soft, non-fraying cloth, moistened lightly.

9.2 Servicing

Remove loose dirt from beneath the load plate at 4-weekly intervals.

To do this, remove the load plate and remove loose dirt with a brush or vacuum cleaner.

Replace the load plate and check the zero point of the scale. Switch the scale off and on if necessary.

Testing the weight display

Place reference weight of 2x3 kg on the scale and read off the display at 3 and 6kg.

This test must be repeated at regular intervals.

10 Technical data

10.1 Dimensions

- Ⓣ Depth: 395 mm
- Ⓜ Width: 343 mm
- Ⓜ Overall height: 115 mm
- Ⓣ₁ Foot distance: 300 mm
- Ⓣ₂ Foot distance: 248 mm

Fig.: Scale housing dimensions

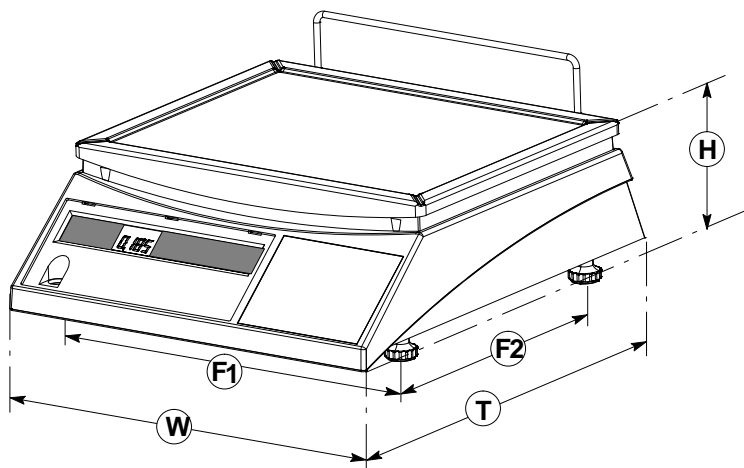

10

- Ⓣ Depth: 53 mm
- Ⓜ Width: 210 mm
- Ⓜ Height: 91 mm
- Ⓣ₂ Complete depth: 437 mm
- Ⓜ₂ Complete height: 424 mm

Fig.: Stand dimensions

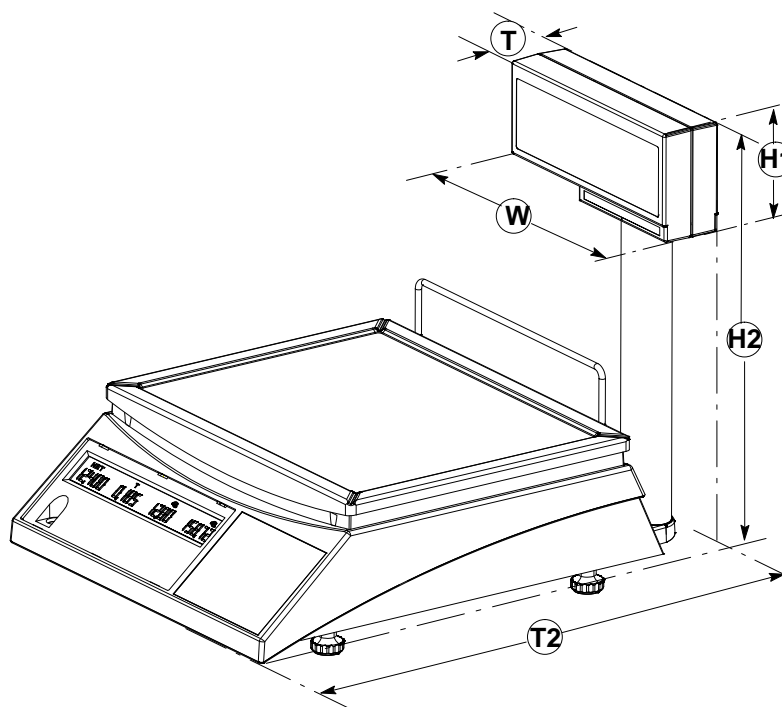

10.2 Power supply

Technical data of power supply

Power connection

Single-phase A.C. voltage, see data on type plate,
220 V / 230 V / 240 V

110 V / 120 V

Permitted tolerance range of supply voltage (statical), normal:

+10% to -15% of nominal value

Supply frequency:

50 (60) Hz

Permitted tolerance of supply frequency:

+2 bis -2%

Permitted distortion factor of supply voltage:

≤ 5%

Max. leakage current of protective ground wire:

3,5 mA

Technical data of the external 12V power supply

Voltage, min. = 11V, max. = 14V

Average current consumption: 200mA

The power source (external battery) must meet the requirements of the power limiter complying with UL 60950 and IEC 60950-1: 2001, section 2.5 (Limited power source).

10

10.3 Environmental conditions

The following conditions must always be observed when using electronic retail scales, POS terminals, weighing and EDP systems, recording equipment and similar devices, equipment combinations and spare parts.

For other manufacturers' equipment included in our scope of supply, the respective manufacturer's regulations take preference if they deviate from our conditions.

Threshold values

Type of equipment	Protection type IP	Temperature °C Celsius (degF Fahrenheit)				Relative air humidity %			
		Operation		Storage		Operation		Storage	
		min.	max.	min.	max.	min.	max.	min.	max. ¹
EDP systems	20	+15 (+60)	+30 (+87)	-10 (+14)	+43 (+109)	8	80	20	80
Retail scales	20	-10 (+14)	+40 (+104)	-20 (-4)	+60 (+140)		90		90
Equipment from subcontractors	According to specification of manufacturer								

¹ Moisture condensation on equipment should not be allowed to occur.

Index

B

Battery

lifetime, 4 – 7

charging function, 4 – 7, 7 – 8

Battery , icon display, 4 – 8

Battery operation, 4 – 11

C

Changing, batteries, 4 – 9

Cleaning, 9 – 1

Commissioning, 4 – 13, 7 – 11

Conditions for the place of installation, 4 – 1

Configuration, 7 – 5

Connection of direct plug-in transformer unit, , 4 – 5

D

Delete , PLU tare , 6 – 9

Device types, 2 – 1

Dimensions, 10 – 1

Direct plug-in transformer units, 4 – 4

Display, 5 – 1

Control lighting , 7 – 7

Icons, 5 – 1

E

Environmental conditions, 10 – 2

Explanation of symbols, 1 – 2

External, battery operation, 4 – 12

F

Fixed constant , Key function , 7 – 6

Fixed constant key , 7 – 6

Fixing function, Switch on fixing function, 6 – 5

Fixing function , Switch off fixing function, 6 – 5

Foil keyboard, 5 – 2

Function keys, 5 – 3

G

Guidelines, 2 – 4

I

Identification plate, 2 – 2

Initial display, 7 – 1

Installation, 4 – 1

K

Keyboard, 5 – 2

Functions, 5 – 3

keypad, 5 – 2

keypad 10-key , 7 – 5

L

Leveling, 4 – 2

Logbook monitoring, 7 – 14

M

Main program version , 7 – 14

Mains connection, 3 – 2

Mains operation, 4 – 12

Maintenance, 9 – 1

Menu invocation, 7 – 1

Mobile operation, 4 – 1

O

Operating conditions, 2 – 5

Operation

- with batteries, 4 – 11
- with mains and rechargeable batteries,
4 – 8
- with rechargeable batteries, 4 – 7

Operational safety, 3 – 2**Option, 2 – 1****P****Place of installation, 4 – 1****PLU tare, 6 – 9****Power supply, 4 – 3, 10 – 2****Product maintenance, 7 – 2**

- Delete article, 7 – 4
- Delete the product pool , 7 – 4
- PLU, 7 – 2, 7 – 3, 7 – 4
- Set PLU unit price, 7 – 2

Program display , ADC, 7 – 12**Programming**

- Tare value, 7 – 3
- Unit price, 7 – 2

Programming overview, 7 – 17**R****Rechargeable battery, 4 – 6**

- module, 2 – 1

Reset, 6 – 1**Reverification, 2 – 3****S****Safety instructions, 3 – 1****Scale in mobile mode, 4 – 1****Selector switch "Rechargeable
battery or battery", 3 – 1, 4 – 11****Service menu**

- Display the load cell type, 7 – 13

Logbook monitoring, 7 – 14

Program display, Main program , 7 – 14

Servicing, 9 – 1**Set zero, 7 – 6****Settings**

- Charge battery, 7 – 8
- Display lighting , 7 – 7
- Fixed, 7 – 6
- Keyboard, 7 – 5
- Sensitivity, 7 – 9
- Set zero , 7 – 6
- Turn-off time, 7 – 8

Standards, 2 – 4**Supply voltage , 3 – 2, 4 – 3****Switch off, 6 – 1****Switch on, 4 – 13, 6 – 1****T****Tare, 6 – 6**

- Batch tare, 6 – 7
- PLU tare, 6 – 9
- Preset tare, 6 – 8
- unknown tare, 6 – 6

Turn-off time, 7 – 8**U****Unit price input, 6 – 2**

- via PLU call., 6 – 3
- via 10-key keypad, 6 – 2

V**Verification information, 2 – 3****W****Warranty, 2 – 7**

Appendix

Declaration of Conformity

Hauptverwaltung Balingen
P.O. Box 10 01 64, 72301 Balingen
Wilhelm-Kraut-Straße 65
72336 Balingen, Germany

BIZERBA
Bizerba GmbH & Co. KG



Declaration of type conformity

We herewith declare that the design of the non-automatic scales indicated hereafter

Definition:	retail scale
Type:	EC II...
No. of EC type approval certificate:	D06-09-026
No. of notified body for EC type approval certificate:	0102 (PTB)

conforms to the assembly described in the type approval as well as the valid requirements in the following EC guidelines:

Directive on non-automatic weighing instruments	2009/23/EC
EMC directive on electromagnetic compatibility	2004/108/EC
Directive on electrical equipment designed for use within certain voltage limits	2006/95/EC

Harmonized standards and technical specifications applied:

Metrology:	DIN EN 45501: 1992 (OIML R76-1, 2006)
EMC:	DIN EN 61000-6-1/ 2007-10; DIN EN 55022/ 2011-12 DIN EN 61000-3-2/ 2010-03; DIN EN 61000-3-3/ 2014-03
Safety:	DIN EN 60950-1

The Declaration of Conformity only applies with regard to the EC Scales Guideline in conjunction with a conformity certification from an appointed body.

This sentence is omitted when the conformity evaluation has been carried out by Bizerba.

The basis for the declaration of conformity is the contract documents (Bizerba purchase order documents). This declaration will lose its validity in the event of modifications to the above-described device type which have not been agreed with Bizerba or performed by Bizerba.

Date:

01.04.2014

Signature of manufacturer:

i.V.

Title of signatory:

Tudor Andronic
Director Global Retail Development (RSD)
Bizerba GmbH & Co. KG

