



System Class

Systematic versatility



BIZERBA

OPEN
WORLD



Our experience sets standards

We are a family-owned company guided by a commitment to tradition, sustainability and responsibility. Nowadays, based on our core competence of slicing and weighing technology, we offer our customers the industry's largest and most unique range of products and solutions as hardware, software and services, anywhere in the world.

As a globally operating technology company we are guided by our goal and commitment to achieve maxi-

mum results in terms of ergonomic design, hygiene, safety and efficiency. We believe we have a role to play in shaping our markets, and are continually setting new industry standards. In close collaboration with our customers and against a backdrop of technological advancement, we are working to improve our products on a daily basis – resulting in innovations which become new standards.

In order to continue to live up to these requirements, we focus on the highest possible quality standards

and internationally recognized technology standards in our development and manufacturing work. This is how we best support our customers in achieving maximum efficiency and profitable growth.

Our experience sets standards.

That's what sets us apart. Bizerba.

Systematic performance



Our System Class brings together all the necessary features for efficient performance. Its model versions permit many solutions which are characterized by their attributes: Technically sophisticated, suitable for a broad weight range and easy to operate.

It particularly stands out due to its broad range of applications because – thanks to its various model versions – our System Class (SC II) provides just the right solution in all retail segments. All central tasks are covered: Assisted sales, self-service, price labeling and transactions. Additional options expand the range of applications. As a result, a broad range of options is available for you.

The SC II scales comprise a broad weight range and can be operated and cleaned easily. Furthermore, you save energy – but not at the expense of performance. In addition, they ensure good communication: All scales can be connected to the back office as well as with each other. Connections to many external devices are possible as well. This way, you can create an efficient work environment for your business success.

System Class SC II 800 7"



Customer display**

- 7" TFT LCD color display with LED backlight
- Article images
- Cross selling images
- Full screen advertising
- Permanent advertising



Keyboard variety

- Membrane or tactile keyboard*, 84 keys for PLU etc.
- Membrane keyboard can be labeled via write-on inserts, tactile keyboard via a frame*
- Tactile keyboard: Slip-on frame with 24 self-service keys
- SC II 400, 500: Self-service/QS keyboards



Software*

- Platform for:
- RetailControl
 - RetailConnect
 - .CWS*



Printer

- Label printer:
- High print speed
 - Graphic-capable
 - Label sizes and layouts freely configurable
- Linerless printer*:
- Variable label length depending on the data volume



Green IT

- High performance at little energy consumption (without fan)
- Economical components (SD card, LED backlight)
- High efficiency power supply unit



Inner values

- Microsoft operating system
- Fast processor
- Ethernet interface
- SC II 100, 200, 800: Battery pack
- 12 V connection for operation via a car battery*

The SC II 800 7" is a counter scale for assisted sales with a modern and functional design which is ideal for any store environment. It's like an extra sales assistant providing convincing "arguments", e.g. as a result of the ergonomic operating concept with direct visual contact with the customer. Or through advertising and information via the 7" customer display creating appealing buying incentives. Moreover, the scale can be used as a cash register, for inventory, data maintenance and pre-packaging.

It is based on a sophisticated technology with a fast processor, large memory, energy-saving components as well as different interfaces. The integrated printer fulfils many requirements even in the standard version of the scale. In addition, there is a broad range of different keyboards.

* Optional for all SC II models
** Optional for SC II 100, 400 and 800



Functions that add value

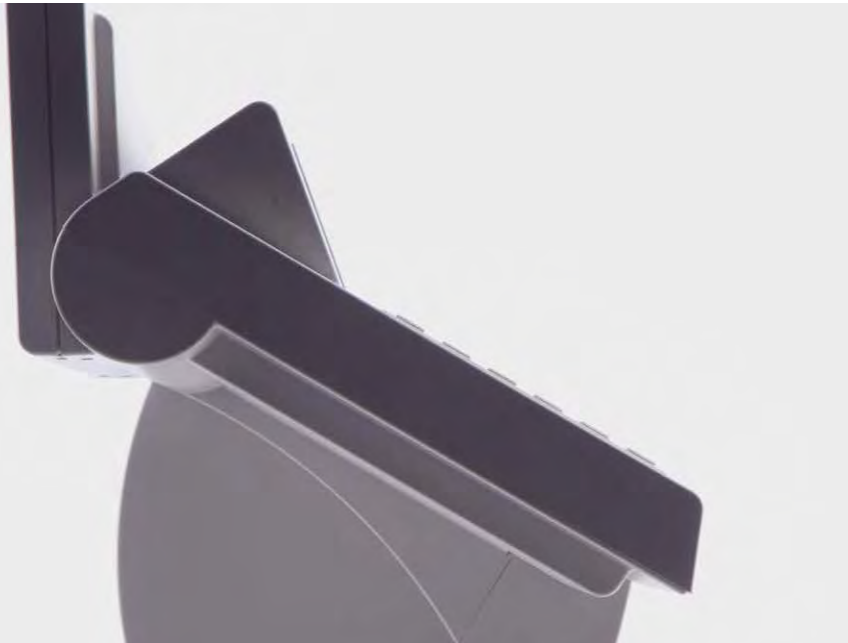

Printer

Powerful equipment right from the outset: The integrated label printer is equipped for label printing or receipt operation. It is part of the standard version of all SC II scales. Important facts: The use of Bizerba consumables increases operational uptime.

The optionally available linerless printer can be fitted with Bizerba linerless thermal rolls without liner. Its advantages: e.g. higher label volumes as a result of longer running lengths, less paper consumption and reduced waste. Sealing instead of stapling: Safe and hygienic sealing of bags by simply attaching a label – no risk arising from staples.

Customer display

Advertising attracts customer interest: Optionally fitted with a 7" LCD color display on the customer side, some of the SC II models stand out regarding their appealing full screen and permanent advertising. Moreover, based on the PLU, product information, pictures or additional product recommendations can be presented. The contents can be easily uploaded via USB stick, via Ethernet through manual distribution or via our RetailImpact software.

On these scales, advertising lists with any number of pictures can be set up for an entire year. When the device is not in use the entire display serves as an advertising medium, but during operation the size of the advertising space is reduced to display permanent advertising only.

Inner values

An "intelligent system" controls all SC II scales: It consists of a Microsoft operating system, a fast processor and Ethernet connection via which the scales communicate with the back office and with each other – even wirelessly if required. Even in the standard version, all relevant hardware interfaces are integrated, such as for cash registers, scanners and E-Cash terminals.

In addition to energy saving components, the scales optionally have an integrated battery. This is a major advantage since they can work without an external power supply which is particularly important for use in the mobile retail sector. A 12 V connection for operation via a car battery is also available as an option.

Data management

Fast flow of data for all activities: The remote service speeds up the communication between back office and the SC II scales. All settings can be checked and modified via remote control. Furthermore, data is managed simultaneously on all scales.

In addition, new scale program updates are transferred to the entire scale system. In parallel with this, all the data is saved automatically and then uploaded into the scale data memory again through a remote update. The dynamic hardware allows a fast response during operation and forms the basis for expansions.

Flexible operating procedures

Many possibilities for operation: Depending on the requirements, the freely configurable tactile or membrane keyboards of the SC II scales can be adjusted to specific operating and operation procedures. PLUs or functions can be assigned to the keys easily.

In order to efficiently support employees the keyboard can be labeled with colored key pictograms using a frame. A complete operating sequence can be started simply at the touch of a button. This saves time and simplifies operation. Moreover, time-controlled reports can be generated without human intervention: upon request, periodically, daily, weekly and monthly reports are printed out on schedule and automatically.

Diversity at the touch of a button

The keyboards of the SC II scales are easily adjustable to your individual requirements. The key functions are freely configurable and the keyboard layout can be customized.



Membrane keyboard



Tactile keyboard

Keyboards SC II 100, 200, 400, 800

There are manifold options since the keyboards are variable through lettering or pictures and different numbers of keys. The keyboards can be labeled individually.



Silicone front membrane with 30 keys



Tactile keyboard with optional 24-key key frame for use in self-service areas



Self-service keyboard with 96 keys and operating keyboard (shown with an optional tactile keyboard)



Self-service keyboard with 48 keys, 24-key self-service key frame fitted onto operating keyboard

Keyboards SC II 500

An equally impressive choice of keys is also available for these self-service keyboards. Text, PLU and graphics can be represented with 24, 48, 72, 96, 120, 192 or 216 tactile keys or with 24 to 216 keys in a mixed arrangement with different key sizes – resulting in the following advantages: Clearly arranged, ease of use and operating safety.



SC II 800 7"

Highlights

Display

- LCD dot matrix display for weight, basic price, sales price and tare display

Keyboard

- Membrane keyboard: Freely programmable

Label printer

- Graphic-capable, printing of logos
- Label sizes and layouts freely configurable, possibility to switch to receipt printing
- Label layout on receipt paper

Operating mode

- Assisted, self-service and quick service sales
- Cash register functions with amount tendered/change operation
- Weight and fixed price labeling

Reports/analyses

- Extensive, freely configurable reporting system for PLU, product groups, main product groups, VAT, operators, department, main department, training
- Sales transaction frequencies for department, product group and operators
- Various sorting criteria
- Price change journal, electronic receipt journal

Options

Licenses for software modules

- Cash register, scanning, e-cash, inventory, re-weighing, returns, delivery note, return delivery, cash invoice, purchase order, proof of origin, operator time recording, video journal, sum QR-barcode

Customer display

- 7" TFT LCD color display
- Article images
- Cross selling images
- Full screen advertising
- Permanent advertising

Keyboard

- Tactile keyboard, 84 keys for PLU and/or further functions
- A slip-on frame with 24 self-service keys can be mounted to the tactile keyboard

Linerless printer

WLAN

Battery operation

- Internal lithium-ion battery pack (not in connection with WLAN), rechargeable via the scale's power supply unit

External battery operation

- 12 V with a special battery connection cable (not in connection with WLAN)

Dimensions

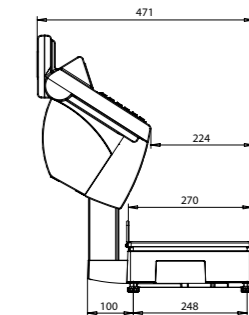
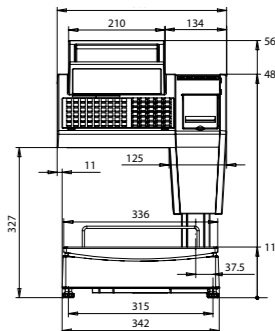
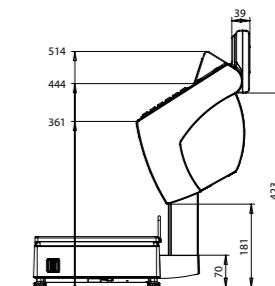



SC II 800

SC II 500

Highlights

Display

- LCD dot matrix display for weight, basic price, sales price and tare display

Keyboard

- Membrane keyboard: Freely programmable

Label printer

- Graphic-capable, printing of logos
- Label sizes and layouts freely configurable, possibility to switch to receipt printing
- Label layout on receipt paper

Operating mode

- Assisted, self-service and quick service sales
- Cash register functions with amount tendered/change operation
- Weight and fixed price labeling

Reports/analyses

- Extensive, freely configurable reporting system for PLU, product groups, main product groups, VAT, operators, department, main department, training
- Sales transaction frequencies for department, product group and operators
- Various sorting criteria
- Price change journal, electronic receipt journal

Options

Licenses for software modules

- Cash register, scanning, e-cash, inventory, re-weighing, returns, delivery note, return delivery, cash invoice, purchase order, proof of origin, operator time recording, video journal, sum QR-barcode

Keyboard

- Tactile keyboard, 84 keys for PLU and/or further functions
- A slip-on frame with 24 self-service keys can be mounted to the tactile keyboard

Linerless printer

WLAN

Battery operation

- Internal lithium-ion battery pack (not in connection with WLAN), rechargeable via the scale's power supply unit

External battery operation

- 12 V with a special battery connection cable (not in connection with WLAN)

Dimensions

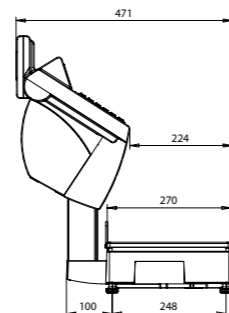
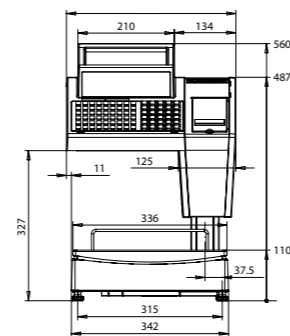
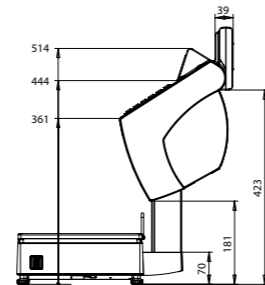

Highlights

Display

- LCD dot matrix display for weight, basic price, sales price and tare display

Keyboard

- Membrane keyboard: Freely programmable
- 24 self-service keys

Self-service keyboard

- Number of self-service keys: Up to 72 or 120
- Possible mixed configuration different key sizes

Quick service keyboard

- Very large quick service keys: 96 standard
- Possible mixed configuration with different key sizes

Label printer

- Graphic-capable, printing of logos
- Label sizes and layouts freely configurable, possibility to switch to receipt printing
- Label layout on receipt paper

Operating mode

- Assisted, self-service and quick service sales
- Cash register functions with amount tendered/change operation
- Weight and fixed price labeling

Options

Licenses for software modules

- Cash register, scanning, e-cash, inventory, re-weighing, returns, delivery note, return delivery, cash invoice, purchase order, proof of origin, operator time recording, video journal, sum QR-barcode

Keyboard

- Tactile keyboard, 84 keys for PLU and/or further functions
- A slip-on frame with 24 self-service keys can be mounted to the tactile keyboard

Self-service keyboard

- Number of self-service keys: 48 standard and further 48 via additional keyboard

Quick service keyboard

- Number of quick-service keys: 96 standard and further 96 via additional keyboard

Linerless printer

WLAN

Dimensions

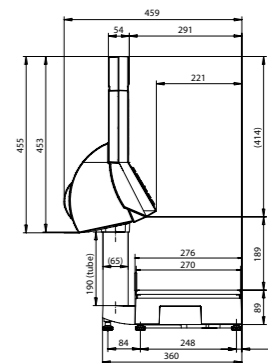
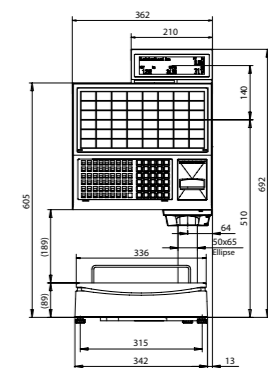



SC II 400 7"

SC II 400

Highlights

Display

- LCD dot matrix display for weight, basic price, sales price and tare display

Keyboard

- Membrane keyboard: Freely programmable
- 24 self-service keys

Self-service keyboard

- Number of self-service keys: Up to 72 or 120
- Possible mixed configuration with different key sizes

Quick service keyboard

- Very large quick service keys: 96 standard
- Possible mixed configuration with different key sizes

Label printer

- Graphic-capable, printing of logos
- Label sizes and layouts freely configurable, possibility to switch to receipt printing
- Label layout on receipt paper
- Talon selectable

Operating mode

- Assisted sales

Options

Licenses for software modules

- Cash register, scanning, e-cash, inventory, re-weighing, returns, delivery note, return delivery, cash invoice, purchase order, proof of origin, operator time recording, video journal, sum QR-barcode

Customer display

- 7" TFT LCD color display
- Article images
- Cross selling images
- Full screen advertising
- Permanent advertising

Keyboard

- Tactile keyboard, 84 keys for PLU and/or further functions
- A slip-on frame with 24 self-service keys can be mounted to the tactile keyboard

Self-service keyboard

- Frame with 24 self-service keys attachable to operating keyboard

Linerless printer

WLAN

Dimensions

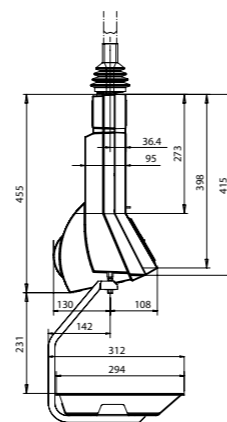
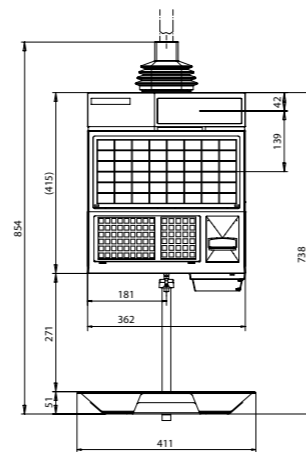

Highlights

Display

- LCD dot matrix display for weight, basic price, sales price and tare display

Keyboard

- Membrane keyboard: Freely programmable
- 24 self-service keys

Self-service keyboard

- Number of self-service keys: Up to 72 or 120
- Possible mixed configuration with different key sizes

Quick service keyboard

- Very large quick service keys: 96 standard
- Possible mixed configuration with different key sizes

Label printer

- Graphic-capable, printing of logos
- Label sizes and layouts freely configurable, possibility to switch to receipt printing
- Label layout on receipt paper
- Talon selectable

Operating mode

- Assisted sales

Options

Licenses for software modules

- Cash register, scanning, e-cash, inventory, re-weighing, returns, delivery note, return delivery, cash invoice, purchase order, proof of origin, operator time recording, video journal, sum QR-barcode

Keyboard

- Tactile keyboard, 84 keys for PLU and/or further functions
- A slip-on frame with 24 self-service keys can be mounted to the tactile keyboard

Self-service keyboard

- Frame with 24 self-service keys attachable to operating keyboard

Linerless printer

WLAN

Dimensions

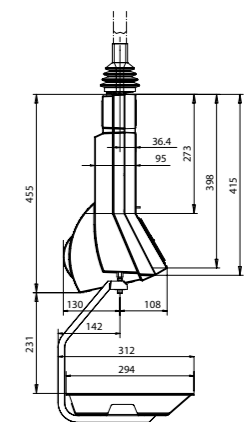
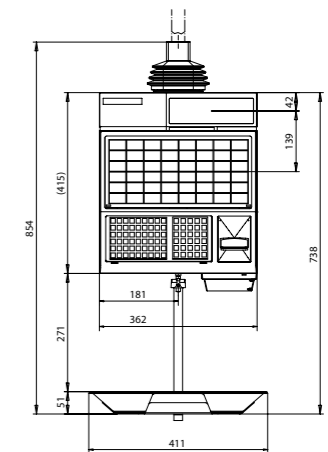



SC II 200

Highlights

Display

- LCD dot matrix display for weight, basic price, sales price and tare display

Keyboard

- Membrane keyboard: Freely programmable

Label printer

- Graphic-capable, printing of logos
- Label sizes and layouts freely configurable, possibility to switch to receipt printing
- Label layout on receipt paper

Operating mode

- Assisted, self-service and quick service sales
- Cash register functions with amount tendered/change operation
- Weight and fixed price labeling

Reports/analyses

- Extensive, freely configurable reporting system for PLU, product groups, main product groups, VAT, operators, department, main department, training
- Sales transaction frequencies for department, product group and operators
- Various sorting criteria
- Price change journal, electronic receipt journal

Options

Licenses for software modules

- Cash register, scanning, e-cash, inventory, re-weighing, returns, delivery note, return delivery, cash invoice, purchase order, proof of origin, operator time recording, video journal, sum QR-barcode

Keyboard

- Tactile keyboard, 84 keys for PLU and/or further functions
- A slip-on frame with 24 self-service keys can be mounted to the tactile keyboard

Linerless printer

WLAN

Battery operation

- Internal lithium-ion battery pack (not in connection with WLAN), rechargeable via the scale's power supply unit within 3.5 hours

External battery operation

- 12 V with a special battery connection cable (not in connection with WLAN)

Dimensions

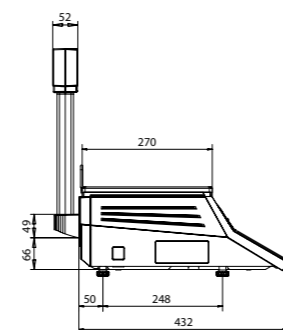
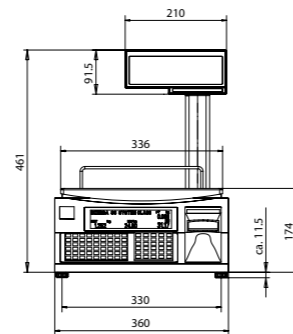

SC II 100 7''

Highlights

Display

- LCD dot matrix display for weight, basic price, sales price and tare display

Keyboard

- Membrane keyboard: Freely programmable

Label printer

- Graphic-capable, printing of logos
- Label sizes and layouts freely configurable, possibility to switch to receipt printing
- Label layout on receipt paper

Operating mode

- Assisted, self-service and quick service sales
- Cash register functions with amount tendered/change operation
- Weight and fixed price labeling

Reports/analyses

- Extensive, freely configurable reporting system for PLU, product groups, main product groups, VAT, operators, department, main department, training
- Sales transaction frequencies for department, product group and operators
- Various sorting criteria
- Price change journal, electronic receipt journal

Options

Licenses for software modules

- Cash register, scanning, e-cash, inventory, re-weighing, returns, delivery note, return delivery, cash invoice, purchase order, proof of origin, operator time recording, video journal, sum QR-barcode

Customer display

- 7" TFT LCD color display
- Article images
- Cross selling images
- Full screen advertising
- Permanent advertising

Keyboard

- Tactile keyboard, 84 keys for PLU and/or further functions
- A slip-on frame with 24 self-service keys can be mounted to the tactile keyboard

Linerless printer

WLAN

Battery operation

- Internal lithium-ion battery pack (not in connection with WLAN), rechargeable via the scale's power supply unit

External battery operation

- 12 V with a special battery connection cable (not in connection with WLAN)

Dimensions

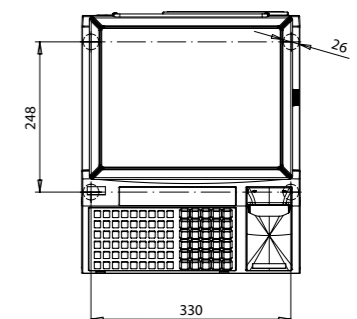
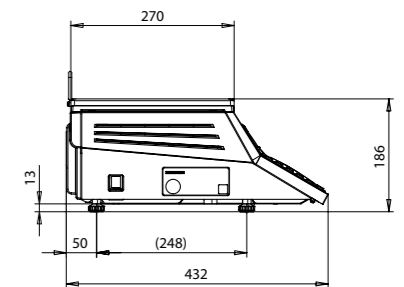
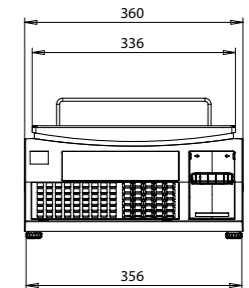



SC II 100

Highlights

Display

- LCD dot matrix display for weight, basic price, sales price and tare display

Keyboard

- Membrane keyboard: Freely programmable

Label printer

- Graphic-capable, printing of logos
- Label sizes and layouts freely configurable, possibility to switch to receipt printing
- Label layout on receipt paper

Operating mode

- Assisted, self-service and quick service sales
- Cash register functions with amount tendered/change operation
- Weight and fixed price labeling

Reports/analyses

- Extensive, freely configurable reporting system for PLU, product groups, main product groups, VAT, operators, department, main department, training
- Sales transaction frequencies for department, product group and operators
- Various sorting criteria
- Price change journal, electronic receipt journal

Options

Licenses for software modules

- Cash register, scanning, e-cash, inventory, re-weighing, returns, delivery note, return delivery, cash invoice, purchase order, proof of origin, operator time recording, video journal, sum QR-barcode

Keyboard

- Tactile keyboard, 84 keys for PLU and/or further functions
- A slip-on frame with 24 self-service keys can be mounted to the tactile keyboard

Linerless printer

WLAN

Battery operation

- Internal lithium-ion battery pack (not in connection with WLAN), rechargeable via the scale's power supply unit

External battery operation

- 12 V with a special battery connection cable (not in connection with WLAN)

Dimensions

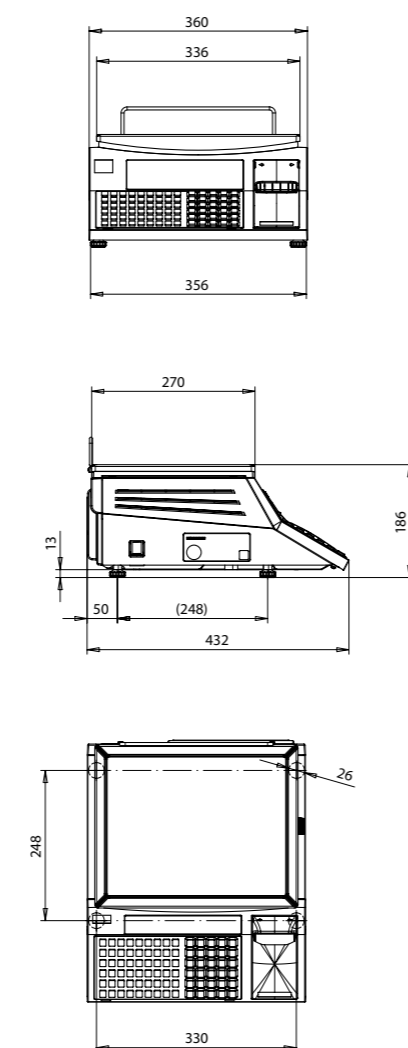

BIZERBA

SC II 100^{B (G)}

Highlights

Display

- LCD dot matrix display for weight, basic price, sales price and tare display

Keyboard

- Membrane keyboard: Freely programmable

Label printer

- Graphic-capable, printing of logos
- Label sizes and layouts freely configurable, possibility to switch to receipt printing
- Label layout on receipt paper

Operating mode

- Assisted, self-service and quick service sales
- Cash register functions with amount tendered/change operation
- Weight and fixed price labeling

Reports/analyses

- Extensive, freely configurable reporting system for PLU, product groups, main product groups, VAT, operators, department, main department, training
- Sales transaction frequencies for department, product group and operators
- Various sorting criteria
- Price change journal, electronic receipt journal

Options

Weighing range

- Various weighing ranges
- Separate load receptors up to 150 kg (SC II 100 G)

Licenses for software modules

- Cash register, scanning, e-cash, inventory, re-weighing, returns, delivery note, return delivery, cash invoice, purchase order, proof of origin, operator time recording, video journal, sum QR-barcode

Keyboard

- Tactile keyboard, 84 keys for PLU and/or further functions
- A slip-on frame with 24 self-service keys can be mounted to the tactile keyboard

Linerless printer

WLAN

- Internal lithium-ion battery pack (not in connection with WLAN), rechargeable via the scale's power supply unit

External battery operation

- 12 V with a special battery connection cable (not in connection with WLAN)

Dimensions

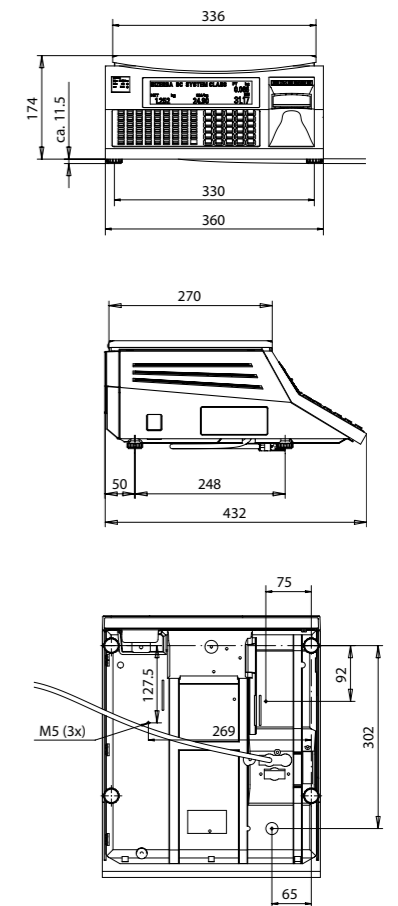

BIZERBA

SC II 100^{B (G)}

SC II 100

For top quality and reliable performance

In your day-to-day work with the SC II scales, you can rely on high-quality cleaning products and original consumables in Bizerba quality. Everything is perfectly matched to your products ensuring the best possible results and longevity of your investment. A perfect example of teamwork with added benefits for you.

Cleaning agents

Optimal functioning and constant availability of your devices and machines requires professional care. Our high quality cleaning agents play an important role here since they are specifically developed for demanding conditions in retail, industry and food service. They are easy to use and show impressive results: perfect cleanliness providing protection as well as disinfecting hygiene for sensitive components and smooth surfaces. For each material whether stainless steel, plastic or glass, we have a suitable cleaning agent in our comprehensive assortment. Clean solutions for your work area or production facility.

Quality labels

Many functions using minimal space: Labels are an indicator for price and ingredients and communicate with industry, trade and end customers via barcodes, QR codes, RF and RFID tags. As a key component of the packaging they fulfill important marketing functions with regard to corporate design, brand names and product marketing. Furthermore, as a production factor, they have an impact on costs and feasibility in the manufacturing process. Our quality labels offer almost unlimited possibilities: ranging from the ecological, high-quality linerless version and thermal-sensitive labels which conform with the Food Information Regulation up to multi-functional labels for product and brand protection. Also here we produce in an economical and innovative manner. Learn more about our labels.



All possibilities at a glance

	SC II 800 with 7"	SC II 800	SC II 500	SC II 400 with 7"	SC II 400	SC II 200	SC II 100 with 7"	SC II 100	SC II 100 G	SC II 100 B
Ideal for										
Sausages/cold cuts	●	●	×	⊖	⊖	●	●	●	●	×
Meat	●	●	×	⊖	⊖	●	●	●	●	×
Cheese	●	●	×	⊖	⊖	●	●	●	●	×
Seafood	⊖	⊖	×	●	●	⊖	⊖	⊖	⊖	×
Fruit/vegetables	●	●	●	●	●	●	●	●	●	×
Bread/bakery department	●	●	×	⊖	⊖	●	●	●	●	●
Non-food	●	●	×	⊖	⊖	●	●	●	●	●
Application										
Counter service	●	●	×	●	●	●	●	●	●	●
Self-service	⊖	⊖	●	⊖	⊖	⊖	⊖	⊖	⊖	×
Weigh price labeling/pre-packaging	●	●	⊖	●	●	●	●	●	●	●
Goods receiving/commissioning	●	●	⊖	⊖	⊖	●	●	●	●	×
Multimedia applications	●	⊖	×	●	⊖	⊖	●	⊖	×	×
Cash register	●	●	×	⊖	⊖	●	●	●	●	●
Application area										
Food trade	●	●	●	●	●	●	●	●	●	●
Food stores	●	●	⊖	●	●	●	●	●	●	●
Fine foods/delicatessen	●	●	⊖	●	●	●	●	●	⊖	×
Gastronomy/snack bars	●	●	×	⊖	⊖	●	●	●	⊖	⊖
Hardware stores	●	●	●	⊖	⊖	●	●	●	●	⊖
Mobile trading	●	●	×	⊖	⊖	●	●	●	●	⊖
Equipment										
Self-service keyboard with 48 keys	×	×	●	⊖	⊖	×	×	×	×	×
Self-service keyboard with 96 keys	×	×	●	⊖	⊖	×	×	×	×	×
Tactile keyboard for 24 direct PLU keys*	●	●	●	●	●	●	●	●	●	●
Tactile keyboard for 30 direct PLU keys*	●	●	●	●	●	●	●	●	●	●
Tactile keyboard for 54 direct PLU keys*	●	●	●	●	●	●	●	●	●	●
Options										
Cash register drawer interface	●	●	●	●	●	●	●	●	●	●
WLAN	●	●	●	●	●	●	●	●	●	●
Separate load receptors up to 150 kg	×	×	×	×	×	×	×	×	●	×

*plus 30 additional function keys

Key

- Optimally suitable for this purpose
- ⊖ Suitable for this purpose
- ×

Information to suit your every need

There are various quick and effective routes to finding the perfect solution for your company. Whether you would like to contact us online or prefer to arrange a face-to-face meeting, Bizerba is always happy to help.

In person

If you would like to set up a personal meeting to discuss your on-site circumstances and possibilities, please contact us directly. Our customer advisors are always on hand to assist you, from the initial idea to detailed planning and from implementation to staff training. You can find details of how to contact us on the back page of this brochure.

You can even experience our solutions from all angles "virtually" for yourself thanks to videos and 360° animations. Simply visit our website to see more:

www.bizerba.com

Would you like to learn more?

Are you keen to obtain more detailed information about Bizerba's products? If so, please contact us. Whether these are dimensional drawings, technical information or interface descriptions. We are happy to advise you.

Online

The Bizerba website provides a quick, easy and focused overview of all our product solutions as well as relevant topics relating to weighing, packaging, pricing and labeling.

Members of the Bizerba Group

Bizerba SE & Co. KG

Wilhelm-Kraut-Straße 65
72336 Balingen
Germany

T +49 74 33 12-0
F +49 74 33 12-2696
info@bizerba.com

www.bizerba.com

Bizerba USA Inc.

1804 Fashion Court
Joppa, MD 21085
USA

T Office +1 732 565-6000
T Service +1 732 565-6001
F +1 732 819-0429
us.info@bizerba.com

www.bizerbausa.com

Bizerba UK Limited

2-4 Erica Road
Stacey Bushes
Milton Keynes
Buckinghamshire
MK12 6HS

UK
T +44 1908 6827-40
F +44 1908 6827-77
sales@bizerba.co.uk

www.bizerba.com

Bizerba Canada Inc.

6411 Edwards Blvd
Mississauga
Ontario L5T2P7
Canada

T +1 888 240-3722
ca.info@bizerba.com

www.bizerba.ca

Bizerba Shanghai

Weigh Tech & Systems Co. Ltd.

D-3, Qianpu Road,
Shuhui Real Est.Park
East New Area of Songjiang,
Ind. Zone
201611 Shanghai
China

T +86 21 676009-99
F +86 21 676009-98
marketing.china@bizerba.cn

www.bizerba.cn

I/440en © 2nd edition. Subject to modifications. 52017

Deviations in color, printing errors due to the photographic material or printing, or changes in construction and model are reserved.