



VS12 vertical slicers Modular variety





The Open World of Finest Weighing Solutions. Since 1866.

Our experience sets standards

We are a family-owned company guided by a commitment to tradition, sustainability and responsibility. Nowadays, based on our core competence of slicing and weighing technology, we offer our customers the industry's largest and most unique range of products and solutions as hardware, software and services, anywhere in the world.

As a globally operating technology company we are guided by our goal and commitment to achieve maximum results in terms of ergonomic design, hygiene, safety and efficiency. We believe we have a role to play in shaping our markets, and are continually setting new industry standards.

In close collaboration with our customers and against a backdrop of technological advancement, we are working to improve our products on a daily basis—resulting in innovations which become new standards.

In order to continue to live up to these requirements, we focus on the highest possible quality standards and internationally recognized technology standards in our development and manufacturing work. This is how we best support our customers in achieving maximum efficiency and profitable growth.

Our experience sets standards.

That's what sets us apart. Bizerba



Simply a better cut

If you expect more than average the VS 12 series is a good choice. Design these modular models based on your needs. Even a solution with an integrated scale is possible. High standard in terms of safety, hygiene and ergonomics.

Keeping your daily work in mind we were using it as a yardstick when designing our VS12 vertical slicers. One result is the low design of the VS12 models. These ergonomically to operate slicers allow you to keep eye contact with the customer at all times.

This building-block principle gives you the flexibility you need concerning the product to be sliced or the device setup, for example. Design your individual solution with a broad variety of configuration options and accessories. Achieve

precise and efficient slicing results. You may operate these slicers manually, semi-automatically or fully automatically. With the optionally integrated portion scale you can achieve slicing results as accurate as 1 g.

Benefit from a solution which complies with the highest safety and hygiene standards. And they are designed for optimum comfort during use. Efficient and sustainable in every phase—from slicing up to weighing and packaging.

VS12 W

Efficient, safe and up-to-the-gram slicing—this is what the VS12 W with integrated portion scale stands for. You slice and weigh your product in one step. Thereby, this sophisticated safety concept protects you with its visual and technical components. The modern touch display indicates the current weight. Even the blade speed can be easily regulated on the display.

The vertical carriage ensures ergonomic, upright operation while providing an optimal view of the slicing result. Our high-performance VS12 W offers a broad variety of product presentation options. This is possible due to a powerful blade drive. It can be individually fitted with the intelligent Emotion® drive technology. This technology adapts the power of an extremely quiet motor to the product's resistance. Even if the machine is heavily used, its surface remains cool and your products stay fresh for longer.

The surface of the VS12 W provides optimal gliding properties and a smooth product guidance. This effect is reinforced by the optional Ceraclean® surface. The excellent non-stick properties additionally allow easy and thorough cleaning. Besides a hygienic design, tool-free disassembly and dishwasher-safe components this is yet another advantage of these models.



Ergonomics

- Low design
- Smoothly running carriage
- Ergonomically adjustable gauge plate
- Fatigue-free operation
- Control via membrane keyboard
- Sliding grooves in carriage plate + gauge plate + blade cover

Touch-Display

- Easy to operate, suitable for many glove types
- Clearly arranged user interface
- Configuration options
- Blade speed regulation
- Weight display

Emotion®*

- Intelligent drive technology
- Reduced energy consumption
- Minimal heat generated in the device and hence in the product
- Very low noise level



* optional



Safety

- Remnant holder, hand guard and rear wall keep hands away from the hazardous area
- Stable blade guard and cover
- Illumination: Visual display showing the current device mode*
- Automatic switch-off function after a preset time interval



Hygiene

- Smooth, rounded surface
- Ceraclean® surface
- Generous distance between motor tower and blade
- Removable, dishwasher-safe sharpener

Ceraclean®*

- Exclusive surface finish
- Excellent gliding properties
- Easy product guidance
- Rapid cleaning
- Dishwasher safe



Efficient processes



Hygiene

The hygienic design of the VS12 series guarantees high-quality products and efficient cleaning. There is nowhere for dirt to collect. The large distance between motor tower and blade makes cleaning easier. The blade cover prevents product residues or liquids from soiling the environment during operation. Surfaces refined with Ceraclean® impress thanks to their optimal non-stick properties thereby enhancing the gliding properties: Liquids simply run off, and greasy and very sticky remnants can be removed quickly. All removable parts can be disassembled without tools and, like the removable sharpener, are dishwasher-safe. This also extremely reduces cleaning times.

Ergonomic design

Due to the ergonomic design of the VS12 series you can fully concentrate on your work and your customers. The high-performance technology, the modular machine concept and the convenient control via touch display provide the best operational comfort. The low design and an adjustable gauge plate allow fatigue-free operation. You benefit from efficient processes and increased productivity: Slicing is intuitive, safe and effortless. The smooth running carriage supports easy slicing by means of its sliding grooves. Even heavy product can be manually sliced with minimal effort.

Energy efficiency

In the VS12 series we have integrated a high-performance and energy-efficient motor concept. Benefit from a powerful motor. It is even possible to achieve a clean cut in dry-cured ham. The Emotion® intelligent drive technology enables you to reduce energy costs with every slice: The motor adapts its performance to the individual resistance of the product. Meanwhile, you benefit from improved product quality: Only a tiny amount of heat is generated around the blade and in the depositing area. Your product stays fresh longer and the service life of electronic components is increased. An additional positive effect for your employees and customers alike is the fact that the motor is extremely quiet, contributing to a pleasant in-store atmosphere.



Individual depositing types

The VS12 series offers a broad spectrum of depositing patterns. Fresh products presented in various patterns are appealing to customers. Models VS12 A and VS12 D come with an automatic depositing system. Portions or stacks can be created and perfectly presented in a hygienic manner without touching the sliced product. You may choose between stacking, shingling or circular patterns. Or, you create your own depositing pattern. You decide the quantity and depositing pattern of your product. Product you want to present in the form of a circular pattern can be directly deposited onto an optional round platter. The entire depositing system can be easily and quickly disassembled and cleaned in the dishwasher. It is ideally suitable for complete and efficient cleaning.

Integrated weighing technology

The VS12 series represents real added value. We have developed solutions which bring together the tasks of slicing and portion control weighing. An integrated scale makes it possible. You control the target weight during slicing: As soon as the predefined target weight is reached the stop function of the VS12 D ends the slicing process. Another integrated function of this model is an automatic slice counter. Your advantages: You work efficiently at the service counter with everything close to hand while having optimal customer contact. The benefit for your customers: less queuing.

Safety

For the VS12 series, operator protection has a high priority. The stable blade guard and the blade cover optimally minimize the risk of injury. The illuminated slice thickness knob provides at-a-glance and visually clear information about the device mode (Green: closed slice thickness, the blade is motionless. Red: open slice thickness, the blade is in operation). The automatic blade switch-off protects you additionally. You individually define the time interval.



VS12

Highlights

- Hygienic design:
 - Disassembly without tools
 - Removable, dishwasher-safe Ceraclean® parts
 - Large distance between blade and motor tower for easy cleaning by hand
- Fine adjustment of slice thickness between 0 - 3 mm
- Powerful motor, optionally with Emotion®:
 - Intelligent drive technology
 - Reduced energy consumption
 - Only minimal heat generated in the device and hence in the product
 - Very low noise level
- Optional Ceraclean® surface refinement for easy cleaning
- Safe operation: Fully covered slicing area during blade sharpening
- Innovative blade cover: Intelligent quick-close system for easy assembly and disassembly

Options

- Exclusive Ceraclean® surface finish
- Intelligent drive technology Emotion®
- Variable cable outlet: Different mains cable outlet positions possible
- Individual equipment:
 - Blade: Ceraclean® blade, cheese blade, bread blade
 - Remnant holder: Smooth, checkered, with spikes
 - Product fixation device
 - Bias cut device

Dimensions

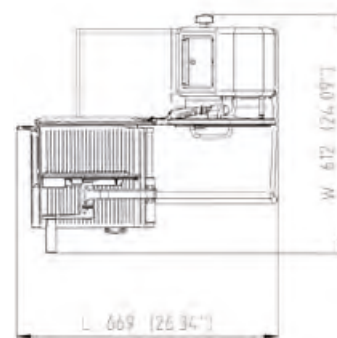
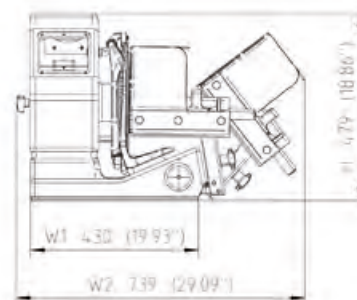
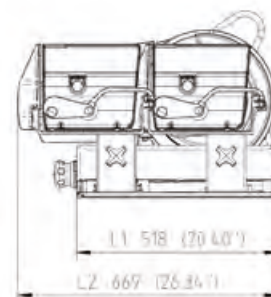



VS12 W

Highlights

- Version with integrated portion scale up to 3 kg
- Intuitive touch display:
 - Weight display and blade speed regulation
 - Sharpening icon indicates that blade must be sharpened
- Hygienic design:
 - Disassembly without tools
 - Removable, dishwasher-safe Ceraclean® parts
 - Large distance between blade and motor tower for easy cleaning by hand
- Fine adjustment of slice thickness between 0 - 3 mm
- Powerful motor, optionally with Emotion®:
 - Intelligent drive technology
 - Reduced energy consumption
 - Only minimal heat generated in the device and hence in the product
 - Very low noise level
- Optional Ceraclean® surface refinement for easy cleaning
- Safe operation: Fully covered slicing area during blade sharpening
- Innovative blade cover: Intelligent quick-close system for easy assembly and disassembly

Options

- Exclusive Ceraclean® surface finish
- Intelligent drive technology Emotion®
- Variable cable outlet: Different mains cable outlet positions possible
- Illumination: Visual display showing the current device mode
- Comfort package: Automatic switch-off function after a preset time interval
- Individual equipment:
 - Blade: Ceraclean® blade, cheese blade, bread blade
 - Remnant holder: Smooth, checkered, with spikes
 - Product fixation device
 - Bias cut device

Dimensions

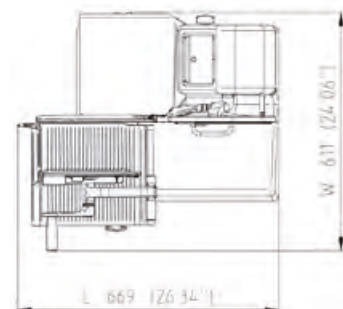
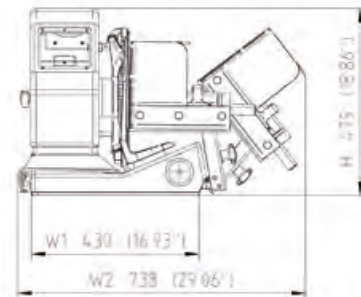
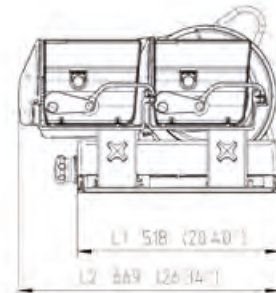

VS12 W



VS12 F

Highlights

- Special feeding carriage for fresh meat
- Hygienic design:
 - Disassembly without tools
 - Removable, dishwasher-safe Ceraclean® parts
 - Large distance between blade and motor tower for easy cleaning by hand
- Sharpening icon indicates that blade must be sharpened, depending on device type
- Fine adjustment of slice thickness between 0 - 3 mm
- Powerful motor, optionally with Emotion®:
 - Intelligent drive technology
 - Reduced energy consumption
 - Only minimal heat generated in the device and hence in the product
 - Very low noise level
- Optional Ceraclean® surface refinement for easy cleaning
- Safe operation: Fully covered slicing area during blade sharpening
- Innovative blade cover: Intelligent quick-close system for easy assembly and disassembly

Options

- Exclusive Ceraclean® surface finish
- Intelligent drive technology Emotion®
- Variable cable outlet: Different mains cable outlet positions possible
- Illumination: Visual display showing the current device mode
- Comfort package: Automatic switch-off function after a preset time interval
- Individual equipment:
 - Blade: Ceraclean® blade, cheese blade, bread blade
 - Remnant holder: Smooth, checkered, with spikes
 - Product fixation device
 - Bias cut device
- Version with integrated portion scale up to 3 kg / 2 g

Dimensions

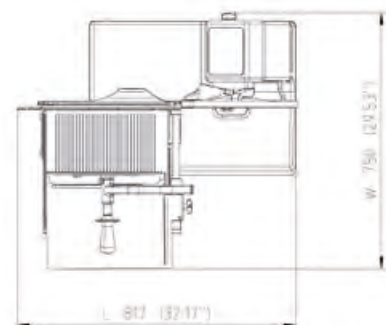
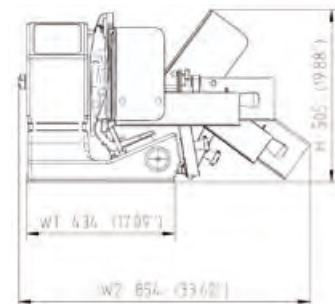
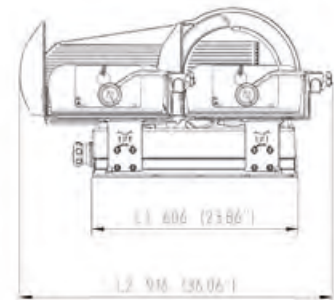



VS12 FP

Highlights

- Special feeding carriage for fresh meat
- Hygienic design:
 - Disassembly without tools
 - Removable, dishwasher-safe Ceraclean® parts
 - Large distance between blade and motor tower for easy cleaning by hand
- Sharpening icon indicates that blade must be sharpened, depending on device type
- Fine adjustment of slice thickness between 0 - 3 mm
- Powerful motor, optionally with Emotion®:
 - Intelligent drive technology
 - Reduced energy consumption
 - Only minimal heat generated in the device and hence in the product
 - Very low noise level
- Innovative blade cover: Intelligent quick-close system for easy assembly and disassembly

Options

- Intelligent drive technology Emotion®
- Variable cable outlet: Different mains cable outlet positions possible
- Individual equipment:
 - Blade: Ceraclean® blade, cheese blade, bread blade
 - Remnant holder: With spikes
 - Product clamping
 - Bias cut device
- Version with integrated portion scale up to 3 kg / 2 g

Dimensions

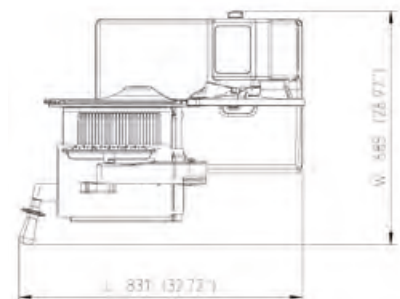
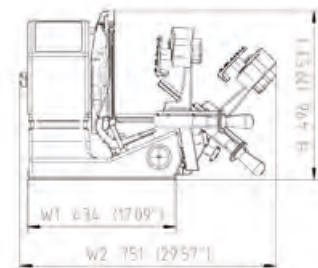
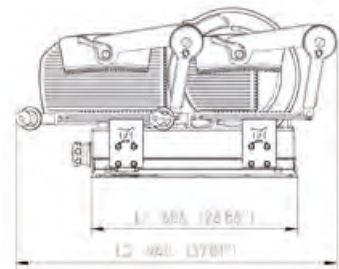

VS12 FP



VS12 A

Highlights

- Semi-automatic vertical slicer for touchless slicing
- Hygienic design:
 - Disassembly without tools
 - Removable, dishwasher-safe Ceraclean® parts
 - Large distance between blade and motor tower for easy cleaning by hand
- Fine adjustment of slice thickness between 0 - 3 mm
- Powerful motor, optionally with Emotion®:
 - Intelligent drive technology
 - Reduced energy consumption
 - Only minimal heat generated in the device and hence in the product
 - Very low noise level
- Optional Ceraclean® surface refinement for easy cleaning
- Variable and manifold depositing: Stacks or shingles, also directly onto paper or foil
- Safe operation: Fully covered slicing area during blade sharpening
- Innovative blade cover: Intelligent quick-close system for easy assembly and disassembly

Options

- Exclusive Ceraclean® surface finish
- Intelligent drive technology Emotion®
- Individual equipment:
 - Blade: Ceraclean® blade, cheese blade, bread blade
 - Remnant holder: Smooth, checkered, with spikes
 - Round platter

Dimensions

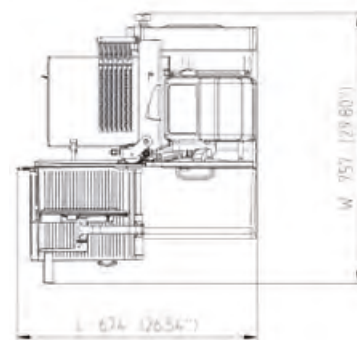
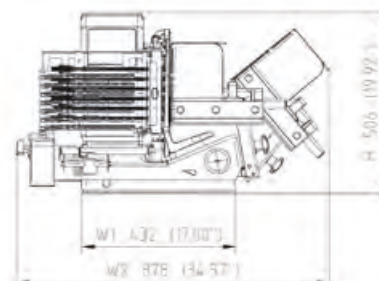



VS12 A W

Highlights

- Semi-automatic vertical slicer with integrated portion scale for touchless slicing
- Integrated portion scale up to 1.5 kg
- Touch display for displaying weight
- Hygienic design:
 - Disassembly without tools
 - Removable, dishwasher-safe Ceraclean® parts
 - Large distance between blade and motor tower for easy cleaning by hand
- Fine adjustment of slice thickness between 0 - 3 mm
- Powerful motor, optionally with Emotion®:
 - Intelligent drive technology
 - Reduced energy consumption
 - Only minimal heat generated in the device and hence in the product
 - Very low noise level
- Optional Ceraclean® surface refinement for easy cleaning
- Variable and manifold depositing: Stacks or shingles, also directly onto paper or foil
- Safe operation: Fully covered slicing area during blade sharpening
- Innovative blade cover: Intelligent quick-close system for easy assembly and disassembly

Options

- Exclusive Ceraclean® surface finish
- Intelligent drive technology Emotion®
- Individual equipment:
 - Blade: Ceraclean® blade, cheese blade, bread blade
 - Remnant holder: Smooth, checkered, with spikes
 - Round platter

Dimensions

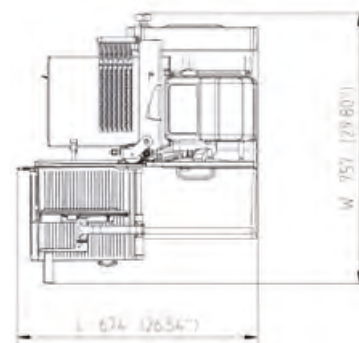
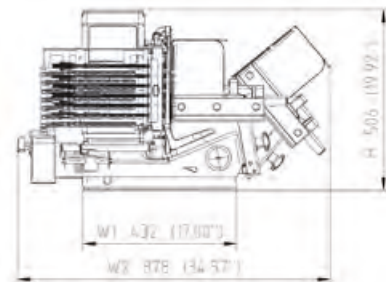

VS12 A W



VS12 D

Highlights

- Fully automatic vertical slicer for touchless slicing
- Servo-supported manual operation
- Hygienic design:
 - Disassembly without tools
 - Removable, dishwasher-safe Ceraclean® parts
 - Large distance between blade and motor tower for easy cleaning by hand
- Fine adjustment of slice thickness between 0 - 3 mm
- Powerful motor with Emotion®:
 - Intelligent drive technology
 - Reduced energy consumption
 - Only minimal heat generated in the device and hence in the product
 - Very low noise level
- Optional Ceraclean® surface refinement for easy cleaning
- Variable and manifold depositing: Stacks or shingles, also directly onto paper or foil
- Safe operation: Fully covered slicing area during blade sharpening
- Innovative blade cover: Intelligent quick-close system for easy assembly and disassembly

Options

- Exclusive Ceraclean® surface finish
- Individual equipment:
 - Blade: Ceraclean® blade, cheese blade, bread blade
 - Remnant holder: Smooth, checkered, with spikes
 - Round platter
 - Shaving deflector
 - Extended carriage for extra large portions

Dimensions

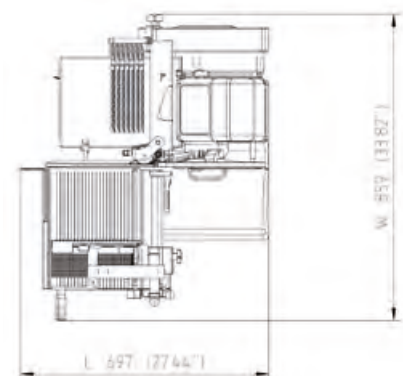
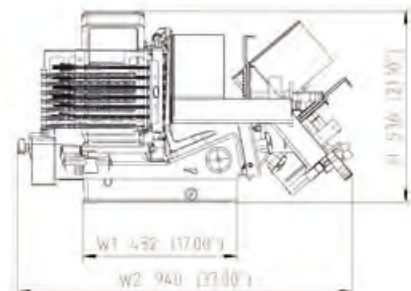
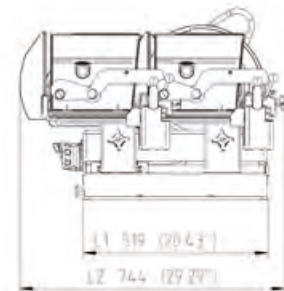



VS12 D W

Highlights

- Fully automatic vertical slicer with integrated portion scale for touchless slicing
- Integrated portion scale up to 1.5 kg
- Touch display with quick selection of the target weight
- Automatic stop function when the target weight is reached
- Servo-supported manual operation
- Hygienic design:
 - Disassembly without tools
 - Removable, dishwasher-safe Ceraclean® parts
 - Large distance between blade and motor tower for easy cleaning by hand
- Fine adjustment of slice thickness between 0 - 3 mm
- Powerful motor with Emotion®:
 - Intelligent drive technology
 - Reduced energy consumption
 - Only minimal heat generated in the device and hence in the product
 - Very low noise level
- Optional Ceraclean® surface refinement for easy cleaning
- Variable and manifold depositing: Stacks or shingles, also directly onto paper or foil
- Safe operation: Fully covered slicing area during blade sharpening
- Innovative blade cover: Intelligent quick-close system for easy assembly and disassembly

Options

- Exclusive Ceraclean® surface finish
- Individual equipment:
 - Blade: Ceraclean® blade, cheese blade, bread blade
 - Remnant holder: Smooth, checkered, with spikes
 - Round platter
 - Shaving deflector
 - Extended carriage for extra large portions

Dimensions

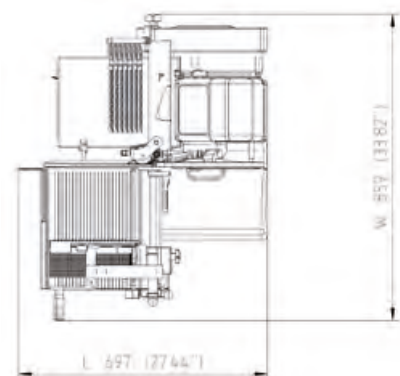
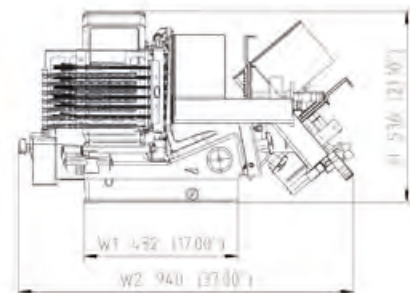
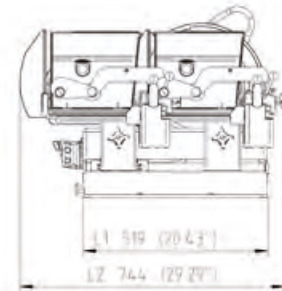

VS12 D W

Simply more options



Thanks to our wide range of accessories you gain access to more opportunities—in terms of products to be sliced and hence your production. Combine model and accessories to match your needs. Quickly, easily and in best Bizerba quality.



Blade options



**Round platter
for paper**

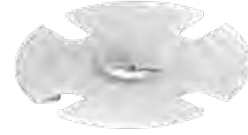

**Round platter
vacuum**



Product clamping



Bias cut device



**Standards carriage
– VS12**



**Carriage for meat
– VS12 F**



**Carriage for bone-in
meat – VS12 FP**



**Extended carriage
– VS12 D**



**Remnant holder plate
grooved**



**Remnant holder plate
smooth**



**Remnant holder plate
with spikes**

All possibilities at a glance

Ideal for

Product	Ideal for						
	Sausages/cold cuts	Meat, fresh	Ham with bones	Cheese	Fruit/veg	Bread	
Vertical slicers, manual							
VSC280	✓	(✓)	–	✓	(✓)	✓	
VS12	✓	(✓)	–	✓	(✓)	✓	
VS12 W	✓	(✓)	–	✓	(✓)	✓	
VS12 F	✓	✓	(✓)	✓	(✓)	✓	
VS12 F35	✓	✓	(✓)	✓	(✓)	✓	
VS12 F37	✓	✓	(✓)	✓	(✓)	✓	
VS12 FP	✓	✓	✓	(✓)	(✓)	✓	
VS12 FP37	✓	✓	✓	(✓)	(✓)	✓	
Vertical slicers, fully automatic/semiautomatic							
VS11 A	✓	(✓)	–	✓	(✓)	(✓)	
VS12 A	with w/o product depositing	✓	(✓)	–	✓	(✓)	(✓)
VS12 A W	with w/o product depositing	✓	(✓)	–	✓	(✓)	(✓)
VS12 D	with w/o product depositing	✓	(✓)	–	✓	(✓)	(✓)
VS12 D W	with w/o product depositing	✓	(✓)	–	✓	(✓)	(✓)
VSI		✓	✓	–	✓	(✓)	(✓)
Industrial slicers							
VSI T		✓	✓	–	✓	(✓)	(✓)
A560		✓	(✓)	–	✓	–	(✓)
A660		✓	(✓)	–	✓	–	(✓)
Gravity feed slicers, manual							
GSP V 25° H	open blade cover	✓	–	–	✓	✓	✓
GSP V 25° L	open blade cover	✓	–	–	✓	✓	✓
GSP H 0°	open closed blade cover	✓	(✓)	–	✓	✓	✓
GSP H 18° L	open closed blade cover	✓	(✓)	–	✓	✓	✓
GSP H 25° L	open closed blade cover	✓	(✓)	–	✓	✓	✓
GSP H 25° H	open closed blade cover	✓	(✓)	–	✓	✓	✓
Gravity feed slicers, fully automatic/semiautomatic							
GSP HD 18° L	open closed blade cover	✓	✓	–	✓	✓	✓
GSP HD 25° L	open closed blade cover	✓	✓	–	✓	✓	✓
GSP HD 25° H	open closed blade cover	✓	✓	–	✓	✓	✓

Legend

- ✓ Suitable for use
- (✓) Possibly suitable for use for the respective application
- Not suitable for this purpose

Application			Application area			Dimensions			Slicing performance	Max. product sizes
Pre-slicing	Presentation	Assisted sales	Retail area (counter)	Canteen kitchen/ restaurant	Industrial	Blade Ø [mm]	Installation area [mm × mm]	Slices/min	Product sizes, round Ø [mm]	Product sizes □[mm]
-	(✓)	✓	✓	✓	-	280	503 x 371		170	230 x 130
-	(✓)	✓	✓	✓	-	330	520 x 433		225	260 x 225
-	(✓)	✓	✓	✓	-	330	520 x 433		225	260 x 175
-	(✓)	✓	✓	✓	-	330	520 x 433		225	260 x 225
-	(✓)	✓	✓	✓	-	350	607 x 433		270	315 x 260
-	(✓)	✓	✓	✓	-	370	607 x 433		270	360 x 290
-	(✓)	✓	✓	✓	-	350	607 x 433		270	320 x 260
-	(✓)	✓	✓	✓	-	370	607 x 433		270	335 x 260
✓	✓	✓	✓	✓	-	280				
✓	✓	✓	✓	✓	-	330			180 225	240 x 175 260 x 175
✓	✓	✓	✓	✓	-	330	520 x 433		180 225	240 x 175 260 x 175
✓	✓	(✓)	✓	✓	(✓)	330	520 x 433	30 – 70	180 225	240 x 175 260 x 175
✓	✓	(✓)	✓	✓	(✓)	330	520 x 433	30 – 70	180 225	240 x 175 260 x 175
✓	✓	(✓)	✓	✓	(✓)	330	606 x 628	30 – 80	180	240 x 180
✓	✓	-	(✓)	✓	✓	330	800 x 847	30 – 80	180	240 x 180
✓	✓	-	-	(✓)	✓	420	1666 x 820	40 – 250	180	210 x 180
✓	✓	-	-	(✓)	✓	420	1666 x 820	40 – 300	180	210 x 180
-	(✓)	✓	✓	✓	-	330	532 x 478		202	290 x 126
-	(✓)	✓	✓	✓	-	330	532 x 478		228	290 x 160
-	(✓)	✓	✓	✓	-	350	532 x 478		260	290 x 246
-	(✓)	✓	✓	✓	-	330	532 x 478		235	290 x 188
-	(✓)	✓	✓	✓	-	330	532 x 478		228	290 x 160
-	(✓)	✓	✓	✓	-	330	532 x 478		202	290 x 126
✓	✓	✓	✓	✓	✓	330	532 x 444	35 – 90	235	290 x 188
✓	✓	✓	✓	✓	✓	330	532 x 444	35 – 90	228	290 x 160
✓	✓	✓	✓	✓	✓	330	532 x 444	35 – 90	202	290 x 126

.....
Semi-automatic machine: Automatic depositing—manual carriage, e.g. VS11 A and VS12 A
Automatic machine: Automatic depositing—automatic carriage, e.g. VS12 D

For top quality and reliable performance

In your day-to-day work with your VS12 vertical slicers, you can rely on high-quality cleaning products and original consumables in Bizerba quality. Everything is perfectly matched to your products ensuring best possible results and longevity of your investment. A perfect example of teamwork with added benefits for you.

Optimal functioning and constant availability of your devices and machines requires professional care. Our high quality cleaning agents play an important role here since they are specifically developed for demanding conditions in retail, industry and food service. They are easy to use and show impressive results: perfect cleanliness providing protection as well as disinfecting hygiene for sensible components and smooth surfaces. For each material whether stainless steel, plastic or glass, we have a suitable cleaning agent in our comprehensive assortment. Clean solutions for your work area or production facility.



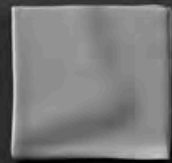

BIZERBA

Perfume

Perfume

Perfume

Perfume

Perfume

Perfume

Perfume

Perfume

Perfume

Perfume

Perfume

Perfume

Perfume

Perfume

Perfume

Perfume

Perfume

Perfume

Perfume

Perfume

Perfume

Perfume

Perfume

Perfume

Perfume

Perfume

Perfume

Perfume

Perfume

Perfume



Our service Professional on-site support

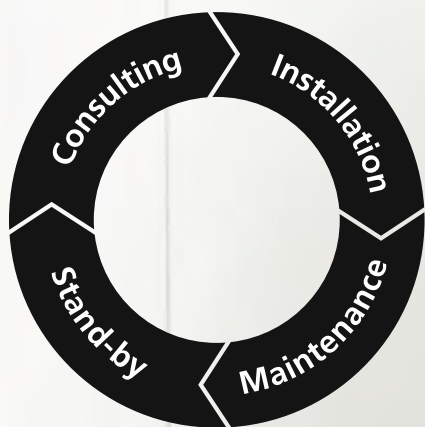

We supplement the use of our VS12 vertical slicers with optimal service. Benefit from our experience and industry know-how. Our highly qualified service experts are at your service nationwide.

In order to obtain the maximum from your investments we are there for you with a multi-level service. This includes advice, start-up and installation of the VS12 slicers as well as other services. Our perfectly matched modules ensure continuous availability.

Service modules

- Individually agreed service contracts
- Start-up including initial training and initial installation
- 24/7 service contract, optional
- Full support (spare parts, technical competence and on-site support)
- Large nationwide network of service experts who are quickly at your service and on-site
- A broad range of care and cleaning products
- Service hotline
- Customer training

Service redefined

My Bizerba



We offer you solutions from a single source which can be customized and allow you to respond to any change in a flexible manner. No matter which modules you are combining for your solution: You benefit from costs which can be planned and efficient processes. And in best Bizerba quality.

Products

- Hardware
- Software & Software Apps
- Labels & Consumables
- Cleaning & care kit
- Starter kit

Services

- Consulting
- Installation
- Maintenance
- On stand-by
- Financing
- Training

Contracts

- Service contracts
- Smart contracts

Information to suit your every need

If you are looking for a fast and reliable way to find the right solutions for your company, there are various routes to the perfect result. Whether you would like to contact us online or prefer to arrange a face-to-face meeting, Bizerba is always happy to help.

In person

You personally want to inform yourself about solutions tailored to your local circumstances? Do not hesitate to contact us. Our customer advisors are always on hand to assist you. From the idea of planning measures up to the implementation and training, our customer service representatives are at your service. You can find details of how to contact us on the back page of this brochure.

Online

The Bizerba website provides a quick, easy and focused overview of all our product solutions as well as relevant topics relating to weighing,

packaging, pricing and labeling. Experience our solutions from all sides. Our solutions can be viewed virtually in a short video or 360° animation. Simply visit our website to see more:

www.bizerba.com

Would you like to learn more?

Are you keen to obtain more detailed information about Bizerba's products? If so, please contact us. Whether these are dimensional drawings, technical information or interface descriptions. We are happy to advise you.



**Let's talk
about it**

Members of the Bizerba Group

Bizerba SE & Co. KG

Wilhelm-Kraut-Straße 65
72336 Balingen
Germany

T +49 7433 12-0
F +49 7433 12-2696

www.bizerba.com

Bizerba USA Inc.

1804 Fashion Court
Joppa, MD 21085
USA

T Office +1 732 565-6000
T Service +1 732 565-6001
F +1 732 819-0429
us.info@bizerba.com

www.bizerba.com

Bizerba UK Limited

2-4 Erica Road
Stacey Bushes
Milton Keynes
Buckinghamshire
MK12 6HS

UK
T +44 1908 6827-40
F +44 1908 6827-77
sales@bizerba.co.uk

www.bizerba.com

Bizerba Canada Inc.

6411 Edwards Blvd
Mississauga
Ontario L5T2P7
Canada

T +1 888 240-3722
ca.info@bizerba.com

www.bizerba.ca

Bizerba Shanghai Weigh Tech & Systems Co. Ltd.

Room 307, Building A
Shanghai Jiuxing Hongqiao
Business Center
NO.9 Shenbin Road
Shanghai
China

T +86 21 676009-99
F +86 21 676009-98
marketing.china@bizerba.cn

www.bizerba.cn

94142000371 © 6th edition 052019. Subject to modifications. Illustration Title: VS12 W

Deviations in color, printing errors due to the photographic material or printing, or changes in construction and model are reserved.
Ceraclean® and Emotion® are registered trademarks of Bizerba SE & Co. KG in at least one EU country and in the USA.